



Service Bulletin

Resetting the No Cooling Fault Code

TNCSTP 120803-B

Purpose

This bulletin provides information on the no cooling fault code and power board resetting procedure.

Applicability

This information applies to NORCOLD gas/electric refrigerator models N51X/N51X.3, N61X/N81X, N62X/N82X, N64X/N84X/N64X.3/N84X.3, N109X, and 120XXX.

Background

A no cooling fault code indicates that the fin temperature in the fresh food compartment is above 50° F and has not lowered in a specific amount of time. Model and corresponding no cooling fault code displayed are shown in Figure 1.

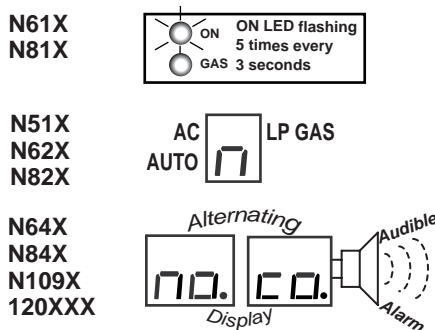

Figure 1. No cooling fault codes

Cooling Performance Monitoring Control

This Control monitors the fin temperature through the thermistor. Monitoring starts when the refrigerator is initially turned on and any time the fin temperature rises above 50° F. When the fin temperature remains above 50° F with no change in cooling detected (within a specific amount of time), the cooling unit heat sources are turned off. The Cooling Unit Monitoring Control will not activate if:

- The fin temperature stays below 50° F.
- The thermistor is disconnected from the circuit.
- Open circuit exists in the thermistor.
- The control senses food compartment door is open (resampling starts 10 minutes after closing door).
- AC voltage is low (below 108 V).
- Frost management feature is active.

Operation Sequence

Steps 1 through 6 describe the operation of the Cooling Unit Monitoring Control:

1. Initial fin temperature monitoring activates when the refrigerator is turned ON and fin temperature is above 50° F. The Monitoring Control deactivates when fin temperature falls below 50° F.
2. The Monitoring Control activates again when the refrigerator controls demand cooling and/or fin temperature rises above to 50° F.
3. Fin temperature is sampled every 10 minutes for a two-hour period.
4. If fin temperature does not decrease below 50° F within this two-hour period, the Monitoring Control deactivates and simultaneously turns off ALL heat sources (AC and Gas) for a 20-minute period.
5. After the 20-minute pause, the Monitoring Control turns on the heat sources (AC and Gas). The refrigerator will continue to operate on the selected operation mode.
6. The Monitoring Control monitors fin temperature every 10 minutes for a 40-minute period.
 - If fin temperature falls during the 40-minute period, monitoring will continue until the fin temperature drops below 50° F.
 - If fin temperature does not fall during the 40-minute period, the Monitoring Control deactivates and locks all heat sources, displays the no cooling fault code (an audible alarm sounds on applicable models).

First No Cooling Fault Code Occurrence

The first no cooling fault code occurrence displayed within a cooling cycle can be cleared by turning the refrigerator OFF and then back ON. This step provides the opportunity to check and correct conditions that may have caused the no cooling fault code. The no cooling fault is stored by the controls and automatically clears when a full cooling cycle is completed.

NOTE

No cooling fault code cannot be cleared through the Diagnostic Mode because it is stored by the Cooling System Monitoring Control.

Second No Cooling Fault Code Occurrence

If a second no cooling fault code occurrence displays after the first occurrence was cleared, the refrigerator controls and venting must be checked by a service center. Once the cause of the second occurrence has been determined and corrected, a power board hardwire reset must be performed by a service center according to the power board resetting procedure that appear on page 2 of this bulletin.

Possible Causes for a No Cooling Fault Code

Possible causes of a no cooling fault code occurrence are listed below; however, always refer to the appropriate model service manual for more specific information.

■ Ventilation Related:

- No ventilation provided.
- Ventilation obstructed.
- Refrigerator not installed per NORCOLD installation instructions and guideline specifications (appropriate baffling, etc.).
- Cooling fan inoperative (on applicable units).

■ Door Related:

- Fresh food or freezer compartment door(s) not closed properly.
- Defective door gaskets on fresh food or freezer compartment.

■ Heat Source Related:

- LP Gas:
 - Dirty burner.
 - Incorrect gas pressure (10 inches below and 11.5 inches above the water column).
 - Wrong size orifice.
 - Wrong burner.
- AC Heater:
 - Incorrect AC heater.
 - Heater not fully seated in heater well.
 - Only one heater working properly (focus on the non-working heater - 120XXX units only).

■ Cooling Unit Related:

- Unit operation exceeding off-level limits.
- Flue cap not positioned properly.
- Flue baffle improperly installed or missing.
- Cooling unit not installed properly (e.g. lack of mastic, etc.).
- Cooling unit leaking.

■ Thermistor on wrong fin.

Power Board Resetting Procedure (performed by service center)

After the second consecutive no cooling fault code, a hardware reset is required to return the refrigerator to service.



WARNING:

The hardwire power board reset must be performed by a service center. Users performing a power board hardwire may void product warranty coverage.

To perform a hardwire power board reset:

1. Turn OFF the refrigerator.
2. Disconnect the following from power board:
 - a. 12 Vdc positive and negative wires.
 - b. AC power cord.
 - c. Solenoid gas valve wires.
 - d. Spark/sense electrode assembly wire. *Exercise extreme caution when disconnecting this wire.*
3. Remove the power board cover.
4. Reconnect the following to the power board (reverse order from step 2):
 - a. Spark/sense electrode assembly wire. *Exercise extreme caution when reconnecting this wire.*
 - b. Solenoid gas valve wires.
 - c. AC power cord.
 - d. 12 Vdc positive and negative wires.
5. Turn ON the refrigerator.
6. Locate Pin 15 on the wire harness 16 pin connector (P1). Pin 15 is the socket to the right of the white/violet wire. See Figure 2, page 3.
7. Using an insulated jumper wire, short Pin 15 to the power board ground lug for 10 to 15 seconds. A click sound will indicate when the controls are reset. See Figure 2, page 3 of the appropriate model service manual.

NOTE

The jumper wire to short Pin 15 to ground can be made from a six inch long insulated 22 AWG wire with a 1/2 inch of insulation stripped from each end.

8. Turn OFF the refrigerator.
9. Turn ON refrigerator to verify that the reset was successful. If the no cooling fault code displays, repeat steps 7 through 9.
10. Turn OFF the refrigerator.
11. Disconnect the following from power board:
 - a. 12 Vdc positive and negative wires.
 - b. AC power cord.
 - c. Solenoid gas valve wires.
 - d. Spark/sense electrode assembly wire. *Exercise extreme caution when disconnecting this wire.*
12. Install the power board cover.
13. Reconnect the following to the power board:
 - a. Spark/sense electrode assembly wire. *Exercise extreme caution when reconnecting this wire.*
 - b. Solenoid gas valve wires.
 - c. AC power cord.
 - d. 12 Vdc positive and negative wires.
14. Place refrigerator in service.

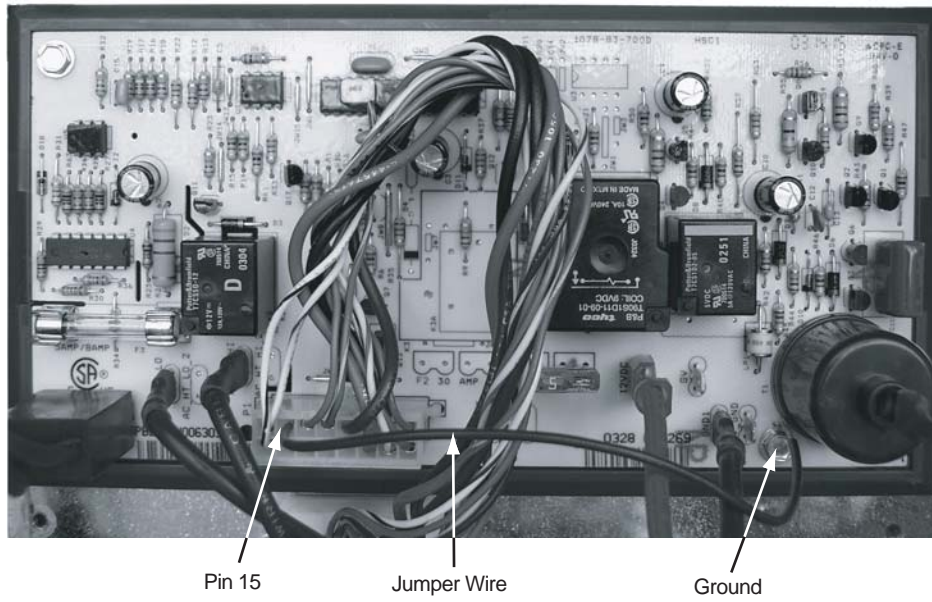

Figure 2. Resetting the power board (model N109X power board shown)