

SHARP

SUPPLEMENTAL SERVICE MANUAL

S62M190R1872E

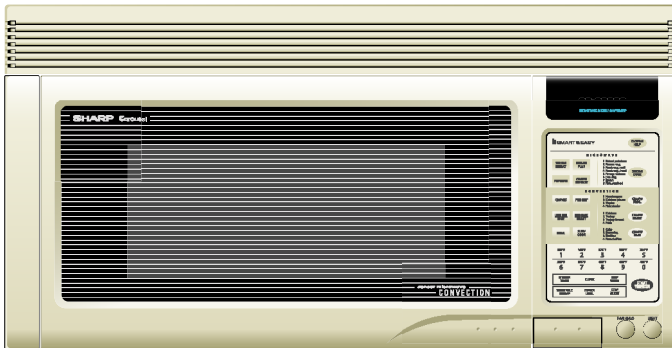

Model R-1872

**OVER THE RANGE
MICROWAVE OVEN**

MODEL R-1872

This is a supplemental Service Manual for Model R-1872.
This model is quite similar to Base Model R-1850 (S/M# S6804R1850X//).
Use this supplemental manual together with the Base Model Service Manuals for complete operation and service information

In the interest of user-safety the oven should be restored to its original condition and only parts identical to those specified should be used.

WARNING TO SERVICE PERSONNEL: Microwave ovens contain circuitry capable of producing very high voltage and current, contact with following parts may result in a severe, possibly fatal, electrical shock. (High Voltage Capacitor, High Voltage Power Transformer, Magnetron, High Voltage Rectifier Assembly, High Voltage Harness etc..)

TABLE OF CONTENTS

	Page
PRECAUTIONS TO BE OBSERVED BEFORE AND DURING SERVICING TO AVOID POSSIBLE EXPOSURE TO EXCESSIVE MICROWAVE ENERGY	INSIDE FRONT COVER
BEFORE SERVICING	INSIDE FRONT COVER
WARNING TO SERVICE PERSONNEL	1
MICROWAVE MEASUREMENT PROCEDURE	2
FOREWORD AND WARNING	3
PRODUCT SPECIFICATIONS	4
GENERAL INFORMATION	4
OPERATION	6
COMPONENT TEST	9
PICTORIAL DIAGRAM	10
LSI UNIT CIRCUIT	11
PARTS LIST	12
PACKING AND ACCESSORIES	18

SHARP ELECTRONICS CORPORATION

This document has been published to be used for after sales service only.

The contents are subject to change without notice.

Service Headquarters: Sharp Plaza, Mahwah, New Jersey, 07430-2135

PRECAUTIONS TO BE OBSERVED BEFORE AND DURING SERVICING TO AVOID POSSIBLE EXPOSURE TO EXCESSIVE MICROWAVE ENERGY

- (a) Do not operate or allow the oven to be operated with the door open.
- (b) Make the following safety checks on all ovens to be serviced before activating the magnetron or other microwave source, and make repairs as necessary: (1) interlock operation (2) proper door closing, (3) seal and sealing surfaces (arcing, wear, and other damage), (4) damage to or loosening of hinges and latches, (5) evidence of dropping or abuse.
- (c) Before turning on microwave power for any service test or inspection within the microwave generating compartments, check the magnetron, wave guide or transmission line, and cavity for proper alignment, integrity, and connections.
- (d) Any defective or misadjusted components in the interlock, monitor, door seal, and microwave generation and transmission systems shall be repaired, replaced, or adjusted by procedures described in this manual before the oven is released to the owner.
- (e) A microwave leakage check to verify compliance with the Federal Performance Standard should be performed on each oven prior to release to the owner.

BEFORE SERVICING

Before servicing an operative unit, perform a microwave emission check as per the Microwave Measurement Procedure outlined in this service manual.

If microwave emissions level is in excess of the specified limit, contact SHARP ELECTRONICS CORPORATION immediately @1-800-237-4277.

If the unit operates with the door open, service person should 1) tell the user not to operate the oven and 2) contact SHARP ELECTRONICS CORPORATION and Food and Drug Administration's Center for Devices and Radiological Health immediately.

Service personnel should inform SHARP ELECTRONICS CORPORATION of any certified unit found with emissions in excess of $4\text{mW}/\text{cm}^2$. The owner of the unit should be instructed not to use the unit until the oven has been brought into compliance.

WARNING TO SERVICE PERSONNEL

Microwave ovens contain circuitry capable of producing very high voltage and current, contact with following parts may result in a severe, possibly fatal, electrical shock.

(Example)

High Voltage Capacitor, High Voltage Power Transformer, Magnetron, High Voltage Rectifier Assembly, High Voltage Harness etc..

Read the Service Manual carefully and follow all instructions.

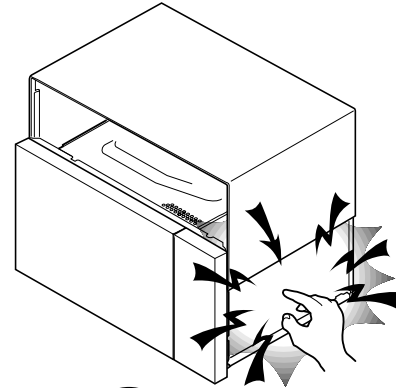

**Don't Touch !
Danger High Voltage**

Before Servicing

1. Disconnect the power supply cord , and then remove outer case.
2. Open the door and block it open.
3. Discharge high voltage capacitor.

**WARNING: RISK OF ELECTRIC SHOCK.
DISCHARGE THE HIGH-VOLTAGE
CAPACITOR BEFORE SERVICING.**

The high-voltage capacitor remains charged about 60 seconds after the oven has been switched off. Wait for 60 seconds and then short-circuit the connection of the high-voltage capacitor (that is the connecting lead of the high-voltage rectifier) against the chassis with the use of an insulated screwdriver.

Whenever troubleshooting is performed the power supply must be disconnected. It may, in some cases, be necessary to connect the power supply after the outer case has been removed, in this event,

1. Disconnect the power supply cord, and then remove outer case.
2. Open the door and block it open.
3. Discharge high voltage capacitor.
4. Disconnect the leads to the primary of the power transformer.
5. Ensure that the leads remain isolated from other components and oven chassis by using insulation tape.
6. After that procedure, reconnect the power supply cord.

When the testing is completed,

1. Disconnect the power supply cord, and then remove outer case.
2. Open the door and block it open.
3. Discharge high voltage capacitor.
4. Reconnect the leads to the primary of the power transformer.
5. Reinstall the outer case (cabinet).
6. Reconnect the power supply cord after the outer case is installed.
7. Run the oven and check all functions.

After repairing

1. Reconnect all leads removed from components during testing.
2. Reinstall the outer case (cabinet).
3. Reconnect the power supply cord after the outer case is installed.
4. Run the oven and check all functions.

Microwave ovens should not be run empty. To test for the presence of microwave energy within a cavity, place a cup of cold water on the oven turntable, close the door and set the power to HIGH and set the microwave timer for two (2) minutes. When the two minutes has elapsed (timer at zero) carefully check that the water is now hot. If the water remains cold carry out **Before Servicing** procedure and re-examine the connections to the component being tested.

When all service work is completed and the oven is fully assembled, the microwave power output should be checked and a microwave leakage test should be carried out.

MICROWAVE MEASUREMENT PROCEDURE

A. Requirements:

- 1) Microwave leakage limit (Power density limit): The power density of microwave radiation emitted by a microwave oven should not exceed 1 mW/cm^2 at any point 5cm or more from the external surface of the oven, measured prior to acquisition by a purchaser, and thereafter (through the useful life of the oven), 5 mW/cm^2 at any point 5cm or more from the external surface of the oven.
- 2) Safety interlock switches: Primary interlock relay and door sensing switch shall prevent microwave radiation emission in excess of the requirement as above mentioned, secondary interlock switch shall prevent microwave radiation emission in excess of 5 mW/cm^2 at any point 5cm or more from the external surface of the oven.

B. Preparation for testing:

Before beginning the actual measurement of leakage, proceed as follows:

- 1) Make sure that the actual instrument is operating normally as specified in its instruction booklet.

Important:

Survey instruments that comply with the requirement for instrumentation as prescribed by the performance standard for microwave ovens, 21 CFR 1030.10(c)(3)(i), must be used for testing.

- 2) Place the oven tray in the oven cavity.
- 3) Place the load of 275 ± 15 ml (9.8 oz) of tap water initially at $20 \pm 5\frac{1}{2}$ C ($68\frac{1}{2}$ F) in the center of the oven cavity.
The water container shall be a low form of 600 ml (20 oz) beaker with an inside diameter of approx. 8.5 cm (3-1/2 in.) and made of an electrically nonconductive material such as glass or plastic.
The placing of this standard load in the oven is important not only to protect the oven, but also to insure that any leakage is measured accurately.
- 4) Set the cooking control on Full Power Cooking Mode.
- 5) Close the door and select a cook cycle of several minutes. If the water begins to boil before the survey is completed, replace it with 275 ml of cool water.

C. Leakage test:

Closed-door leakage test (microwave measurement)

- 1) Grasp the probe of the survey instrument and hold it perpendicular to the gap between the door and the body of the oven.
- 2) Move the probe slowly, not faster than 1 in./sec. (2.5 cm/sec.) along the gap, watching for the maximum indication on the meter.
- 3) Check for leakage at the door screen, sheet metal seams and other accessible positions where the continuity of the metal has been breached (eg., around the switches, indicator, and vents).
While testing for leakage around the door pull the door away from the front of the oven as far as is permitted by the closed latch assembly.
- 4) Measure carefully at the point of highest leakage and make sure that the highest leakage is no greater than 4 mW/cm^2 , and that the secondary interlock switch does turn the oven OFF before any door movement.

NOTE: After servicing, record data on service invoice and microwave leakage report.

SHARP

SERVICE MANUAL

MICROWAVE OVEN

R-1872

FOREWORD

This Manual has been prepared to provide Sharp Electronics Corp. Service Personnel with Operation and Service Information for the SHARP MICROWAVE OVEN, R-1872.

The model R-1872 is quite similar to base model R-1850 (Ref.# S6804R1850X//)

It is recommended that service personnel carefully study the entire text of this manual and the base model's manual so that they will be qualified to render satisfactory customer service.

Check the interlock switches and the door seal carefully. Special attention should be given to avoid electrical shock and microwave radiation hazard.

WARNING

Never operate the oven until the following points are ensured:

- (A) The door is tightly closed.
- (B) The door brackets and hinges are not defective.
- (C) The door packing is not damaged.
- (D) The door is not deformed or warped.
- (E) There is no other visible damage with the oven.

Servicing and repair work must be carried out only by trained service personnel.

DANGER

Certain initial parts are intentionally not grounded and present a risk of electrical shock only during servicing. Service personnel - Do not contact the following parts while the appliance is energized;

**High Voltage Capacitor, Power Transformer, Magnetron, High Voltage Rectifier Assembly, High Voltage Harness;
If provided, Vent Hood, Fan assembly, Cooling Fan Motor.**

All the parts marked "*" on parts list are used at voltages more than 250V.

Removal of the outer wrap gives access to voltage above 250V.

PRODUCT DESCRIPTION

GENERAL INFORMATION

OPERATION

WIRING DIAGRAM

PARTS LIST

SHARP ELECTRONICS CORPORATION

SHARP PLAZA, MAHWAH,
NEW JERSEY 07430-2135

SPECIFICATION

ITEM	DESCRIPTION
Power Requirements	120 Volts / 13.2 Amperes (Microwave), 13.2 Amperes (Convection) 60 Hertz Single phase, 3 wire grounded
Power Output	850 watts (IEC-705 TEST PROCEDURE) Operating frequency of 2450MHz
Convection Power Output	1400 watts
Case Dimensions	Width 29-15/16" Height 16-11/32" Depth 15- 9/32"
Cooking Cavity Dimensions	Width 17-1/8" Height 8-1/16" Depth 13-13/16"
1.1 Cubic Feet	
Hood lamp	2 bulbs, 20W x 2, Incandescent light bulbs
Hood fan	Horizontal discharge 230 C.F.M. , Vertical discharge 240 C.F.M. ,
Control Complement	Touch Control System Clock (1:00 - 12:59) Timer (0 - 99 min. 99 seconds) Microwave Power for Variable Cooking Repetition Rate; P-HI Full power throughout the cooking time P-90 approx. 90% of Full Power P-80 approx. 80% of Full Power P-70 approx. 70% of Full Power P-60 approx. 60% of Full Power P-50 approx. 50% of Full Power P-40 approx. 40% of Full Power P-30 approx. 30% of Full Power P-20 approx. 20% of Full Power P-10 approx. 10% of Full Power P-0 No power throughout the cooking time CUSTOM HELP pad, SENSOR COOK pad, COMPU BROIL pad, COMPU ROAST pad COMPU BAKE pad, SENSOR REHEAT pad, MINUTE PLUS pad, POPCORN pad COMPU DEFROST pad, CONVECTION pad, REHEAT pad, LOW MIX/BAKE pad HIGH MIX/ROAST pad, BROIL pad, SLOW COOK pad, KITCHEN TIMER pad Number and temperature selection pads, CLOCK pad, KEEP WARM pad TURNTABLE ON / OFF pad, POWER LEVEL pad, STOP/CLEAR pad, START / TOUCH ON pad
Oven Cavity Light	Yes 20W x 1 Incandescent light bulb
Safety Standard	UL Listed FCC Authorized DHHS Rules, CFR, Title 21, Chapter 1, Subchapter J
Weight	Approx. 71 lbs.

GENERAL INFORMATION

GROUNDING INSTRUCTIONS

This oven is equipped with a three prong grounding plug. It must be plugged into a wall receptacle that is properly installed and grounded in accordance with the National Electrical Code and local codes and ordinances.

In the event of an electrical short circuit, grounding reduces the risk of electric shock by providing an escape wire for the electric current.

WARNING: Improper use of the grounding plug can result in a risk of electric shock.

Electrical Requirements

The oven is equipped with a 3-prong grounding plug. **DO NOT UNDER ANY CIRCUMSTANCES CUT OR REMOVE THE GROUNDING PIN FROM THE PLUG.**

The power supply cord and plug must be connected to a separate 120 Volt AC, 60 Hz, 15 Amp. or more branch circuit, using a grounded receptacle. The receptacle should be located inside the cabinet directly above the Microwave Oven/Hood system mounting location.

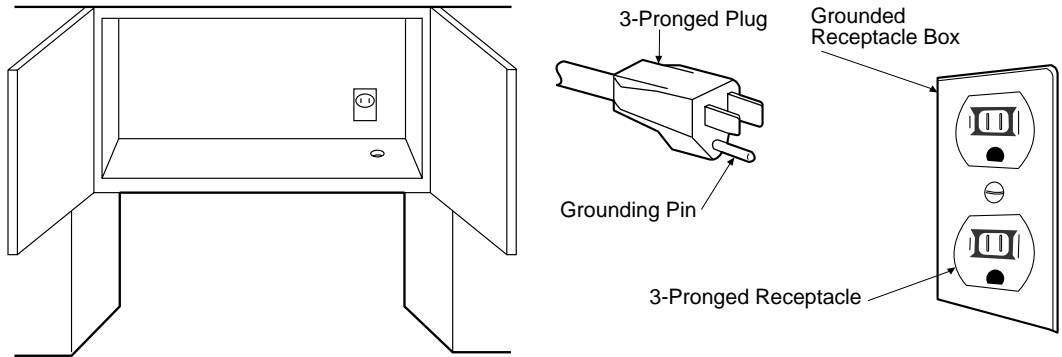

OVEN DIAGRAM

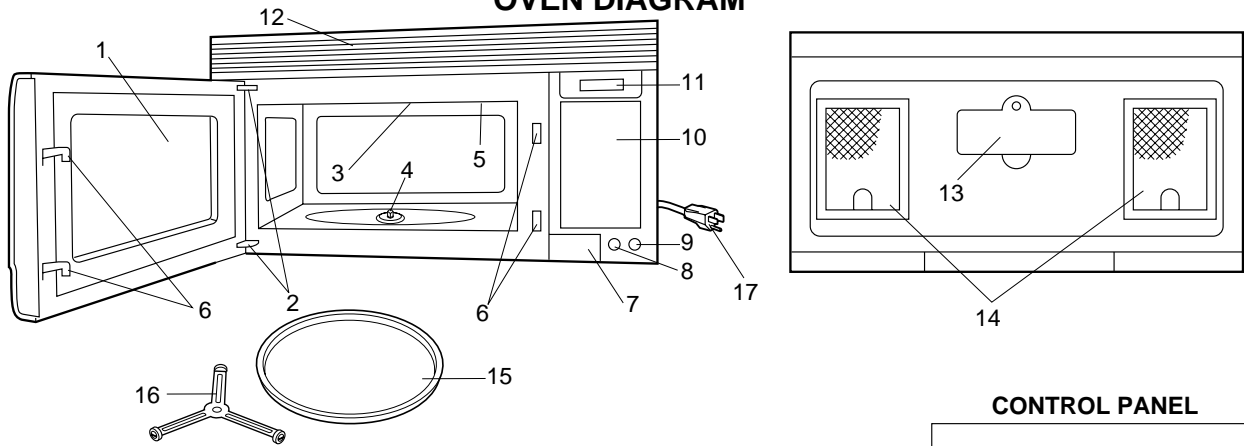

1. Oven door with see-through window.
2. Door hinges.
3. Stirrer cover.
4. Turntable motor shaft.
5. Oven lamp.
It will light when oven is operating or door is open.
6. Door latches.
The oven will not operate unless the door is securely closed.
7. One touch door open button.
Push to open door.
8. FAN-HI/LO button.
Push for High/Low/Off.
9. Light button.
Push for On/Off
10. Auto-Touch control panel.
11. Time display: Digital display, 99 minutes 99 seconds.
12. Ventilation openings.
13. Light Cover.
14. Grease filters.
15. Removable turntable.
The turntable will rotate clockwise or counterclockwise.
Only remove for cleaning.
16. Removable turntable support.
17. Plug

NOTE:
Some one-touch cooking features as "MINUTE PLUS" are disabled after one minute when the oven is not used. These features are automatically enabled when the door is opened and closed or the STOP/CLEAR pad is pressed.

CONTROL PANEL

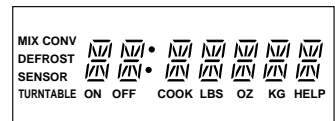

SMART & EASY CUSTOM HELP

MICROWAVE

SENSOR REHEAT	MINUTE PLUS	1 Baked potatoes 2 Frozen veg. 3 Fresh veg.-soft 4 Fresh veg.-hard 5 Frozen entrees 6 Bacon 7 Turkey, seafood	SENSOR COOK
POPCORN	COMPU DEFROST		

CONVECTION

CONVEC	PREHEAT	1 Hamburgers 2 Chicken pieces 3 Steaks 4 Fish steaks	COMPU BROIL
LOW MIX BAKE	HIGH MIX ROAST	1 Chicken 2 Turkey 3 Turkey breast 4 Pork	COMPU ROAST
BROIL	SLOW COOK	1 Cake 2 Brownies 3 Muffins 4 French fries	COMPU BAKE

100°F	150°F	275°F	300°F	325°F
1	2	3	4	5
350°F	375°F	400°F	425°F	450°F
6	7	8	9	0

KITCHEN TIMER	CLOCK	KEEP WARM
TURNTABLE ON/OFF	POWER LEVEL	STOP CLEAR

START TOUCH ON

OPERATION

DESCRIPTION OF OPERATING SEQUENCE

The following is a description of component functions during oven operation.

OFF CONDITION

Closing the door activates the door sensing switch and secondary interlock switch. (In this condition, the monitor switch contacts are opened.)

When oven is plugged in, 120 volts A.C. is supplied to the control unit. (Figure O-1).

- The display will show SHARP, SIMPLY, THE, BEST, PRESS, CLEAR, and PRESS, CLOCK.
To set any program or set the clock, you must first touch the STOP/CLEAR pad. The display will clear, and " : " will appear.

COOKING CONDITION

Program desired cooking time touching the NUMBER pads. When the START pad is touched, the following operations occur:

- The contacts of relays are closed and components connected to the relays are turned on as follows.
(For details, refer to Figure O-2)

RELAY	CONNECTED COMPONENTS
RY1	Oven lamp
RY2	Power transformer/ Stirrer motor
RY4	Turntable motor
RY5	Fan motor

- 120 volts A.C. is supplied to the primary winding of the power transformer and is converted to about 3.3 volts A.C. output on the filament winding, and approximately 2000 volts A.C. on the high voltage winding.
- The filament winding voltage heats the magnetron filament and the H.V. winding voltage is sent to a voltage doubler circuit.
- The microwave energy produced by the magnetron is channelled through the waveguide into the cavity feed-box, and then into the cavity where the food is placed to be cooked.
- Upon completion of the cooking time, the power transformer, oven lamp, etc. are turned off, and the generation of microwave energy is stopped. The oven will revert to the OFF condition.
- When the door is opened during a cook cycle, monitor switch, door sensing switch, primary switch and secondary switch and secondary interlock relay are activated with the following results. The circuits to the stirrer motor, the cooling fan motor, the turntable motor, and the high voltage components are de-energized, and the digital read-out displays the time still remaining in the cook cycle when the door was opened.
- The monitor switch is electrically monitoring the operation

of the primary and secondary switch and secondary interlock relay and is mechanically associated with the door so that it will function in the following sequence.

- When the door opens from a closed position, the secondary interlock relay, door sensing switch, primary and secondary switch open their contacts, and then the monitor switch contacts close.
- When the door is closed from the open position, the monitor switch contacts first open, and then the contacts of the primary and secondary switch close.

If the primary switch, secondary switch and secondary interlock relay fail with their contacts closed when the door is opened, the closing of the monitor switch contacts will form a short circuit through the monitor fuse, secondary switch switch, primary switch and secondary interlock relay, causing the monitor fuse to blow.

POWER LEVEL P-0 TO P-90 COOKING

When Variable Cooking Power is programmed, the 120 volts A.C. is supplied to the power transformer intermittently through the contacts of relay (RY2) which is operated by the control unit within an interval second time base. Microwave power operation is as follows:

VARI-MODE	ON TIME	OFF TIME
Power 10(P-HI) (100% power)	32 sec.	0 sec.
Power 9(P-90) (approx. 90% power)	30 sec.	2 sec.
Power 8(P-80) (approx. 80% power)	26 sec.	6 sec.
Power 7(P-70) (approx. 70% power)	24 sec.	8 sec.
Power 6(P-60) (approx. 60% power)	22 sec.	10 sec.
Power 5(P-50) (approx. 50% power)	18 sec.	14 sec.
Power 4(P-40) (approx. 40% power)	16 sec.	16 sec.
Power 3(P-30) (approx. 30% power)	12 sec.	20 sec.
Power 2(P-20) (approx. 20% power)	8 sec.	24 sec.
Power 1(P-10) (approx. 10% power)	6 sec.	26 sec.
Power 0(P-0) (0% power)	0 sec.	32 sec.

Note: The ON/OFF time ratio does not correspond with the percentage of microwave power, because approx. 2 seconds are needed for heating of the magnetron filament.

SCHEMATIC
 NOTE: CONDITION OF OVEN
 1. DOOR CLOSED.
 2. CLOCK APPEARS ON DISPLAY.

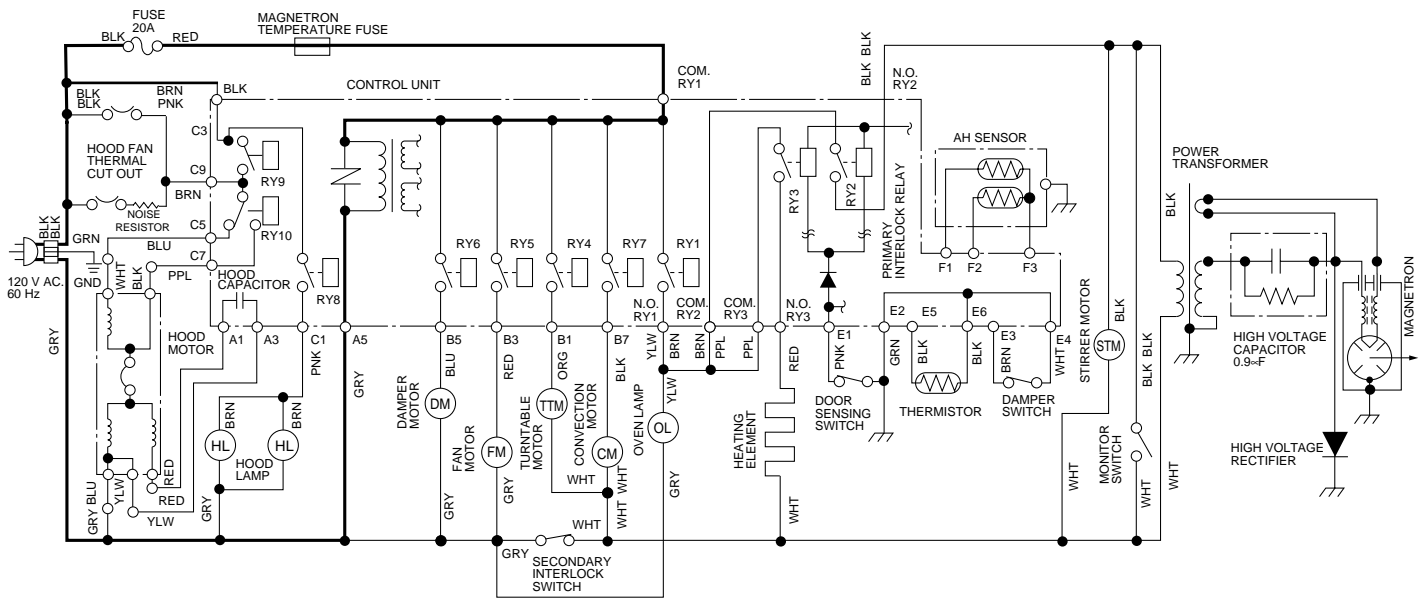

Figure O-1. Oven Schematic - Off Condition

SCHEMATIC
 NOTE: CONDITION OF OVEN
 1. DOOR CLOSED.
 2. COOKING TIME PROGRAMMED.
 3. START PAD TOUCHED.

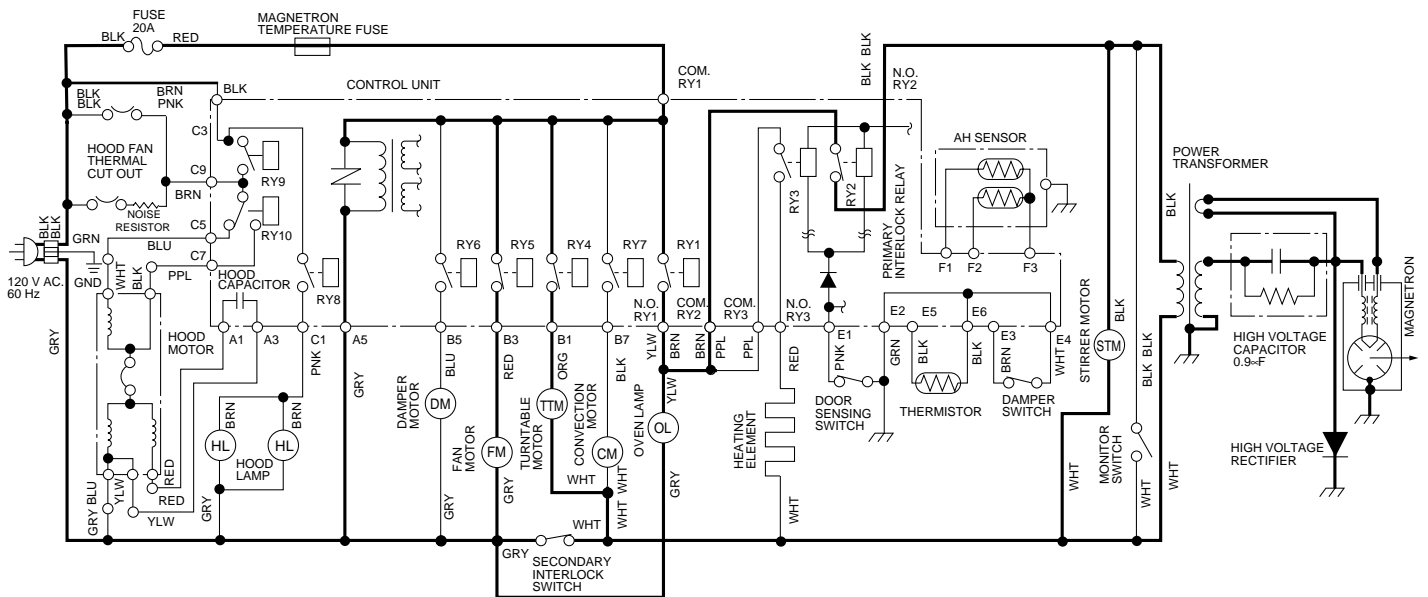

Figure O-2. Oven Schematic - Microwave Cooking Condition

SCHMATIC

NOTE: CONDITION OF OVEN

1. DOOR CLOSED.
2. CONVECTION PAD TOUCHED.
3. DESIRED TEMP. TOUCHED.
4. START PAD TOUCHED.

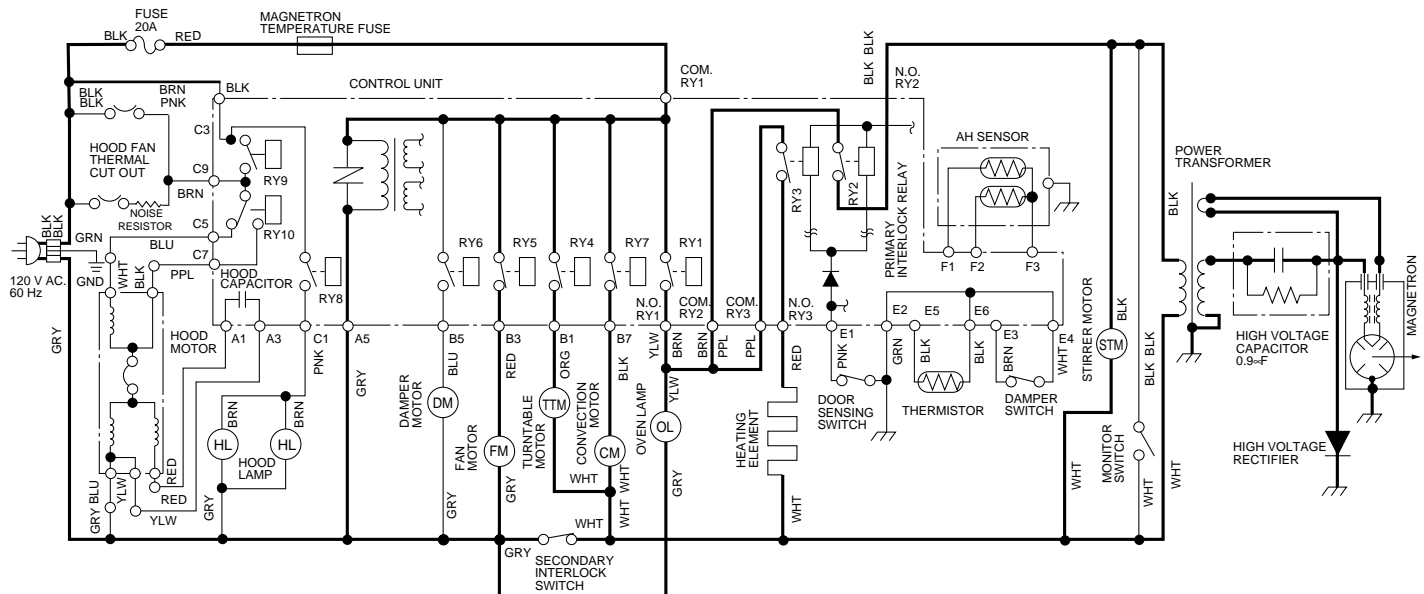

Figure O-3. Oven Schematic - Convection Cooking Condition (CONVEC, PREHEAT, BROIL, SLOW COOK)

SCHMATIC

NOTE: CONDITION OF OVEN

1. DOOR CLOSED.
2. MIX COOKING PAD TOUCHED.
3. DESIRED TEMP. TOUCHED.
4. COOKING TIME PROGRAMMED.
5. START PAD TOUCHED.

NOTE: RY2 and RY3 will alternately close during cook cycle

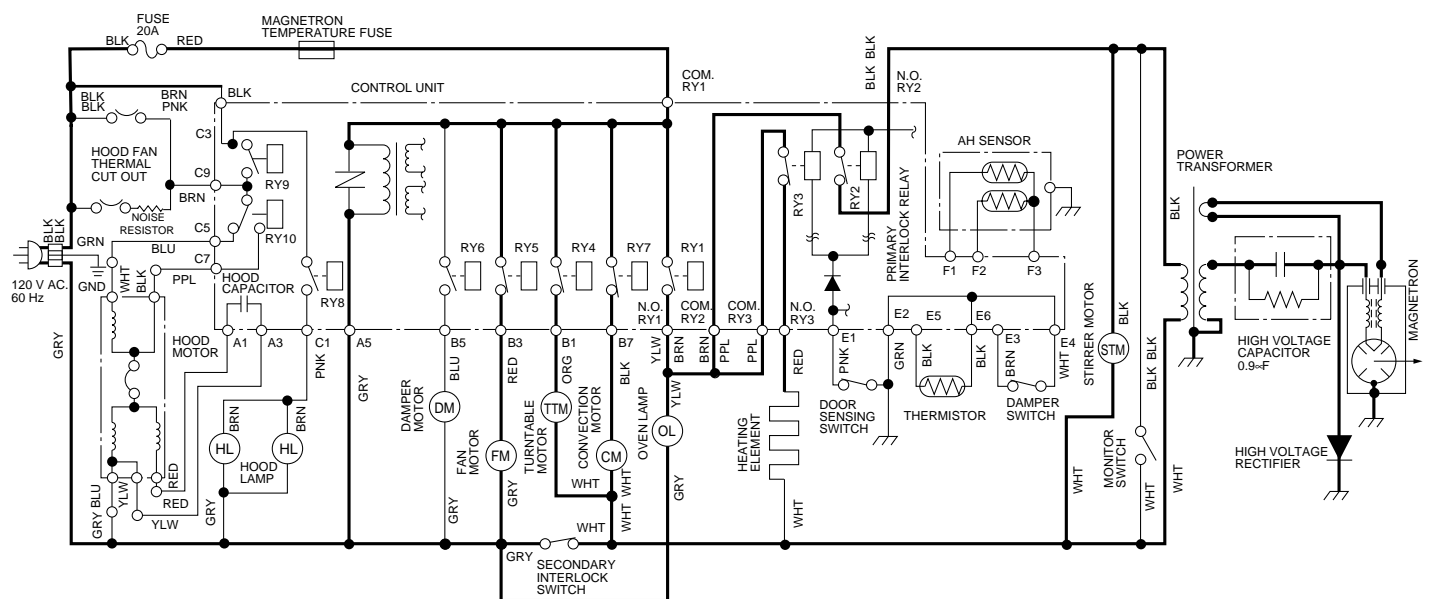

Figure O-4. Oven Schematic - Automatic Mix cooking Condition

**PROCEDURE
LETTER**

COMPONENT TEST

Note: When defective components, the Control Unit or Key Unit are replaced, the defective part or parts must be properly packed for return in the shipping carton, with its cushion material, in which the new replacement part was shipped to you.

R KEY UNIT TEST

If the display fails to clear when the STOP/CLEAR pad is depressed, first verify the flat ribbon is making good contact, verify that the door sensing switch (stop switch) operates properly; that is the contacts are closed when the door is closed and open when the door is open. If the door sensing (stop switch) is good, disconnect the flat ribbon that connects the key unit to the control unit and make sure the door sensing switch is closed (either close the door or short the stop switch connector). Use the key unit matrix indicated on the control panel schematic and place a jumper wire between the pins that correspond to the STOP/CLEAR pad making momentary contact. If the control unit responds by clearing with a beep, the key unit is faulty and must be replaced. If the control unit does not respond, it is faulty and must be replaced. If a specific pad does not respond, the above method may be used (after clearing the control unit) to determine if the control unit or key pad is at fault.

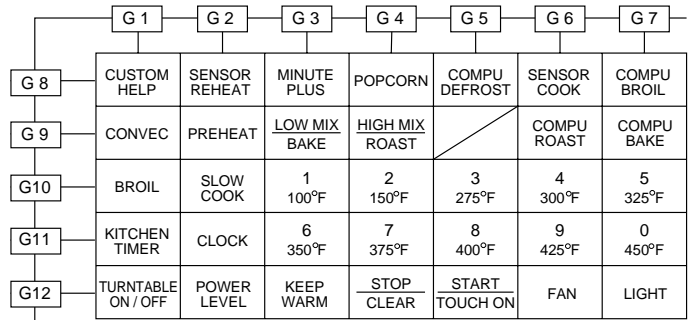

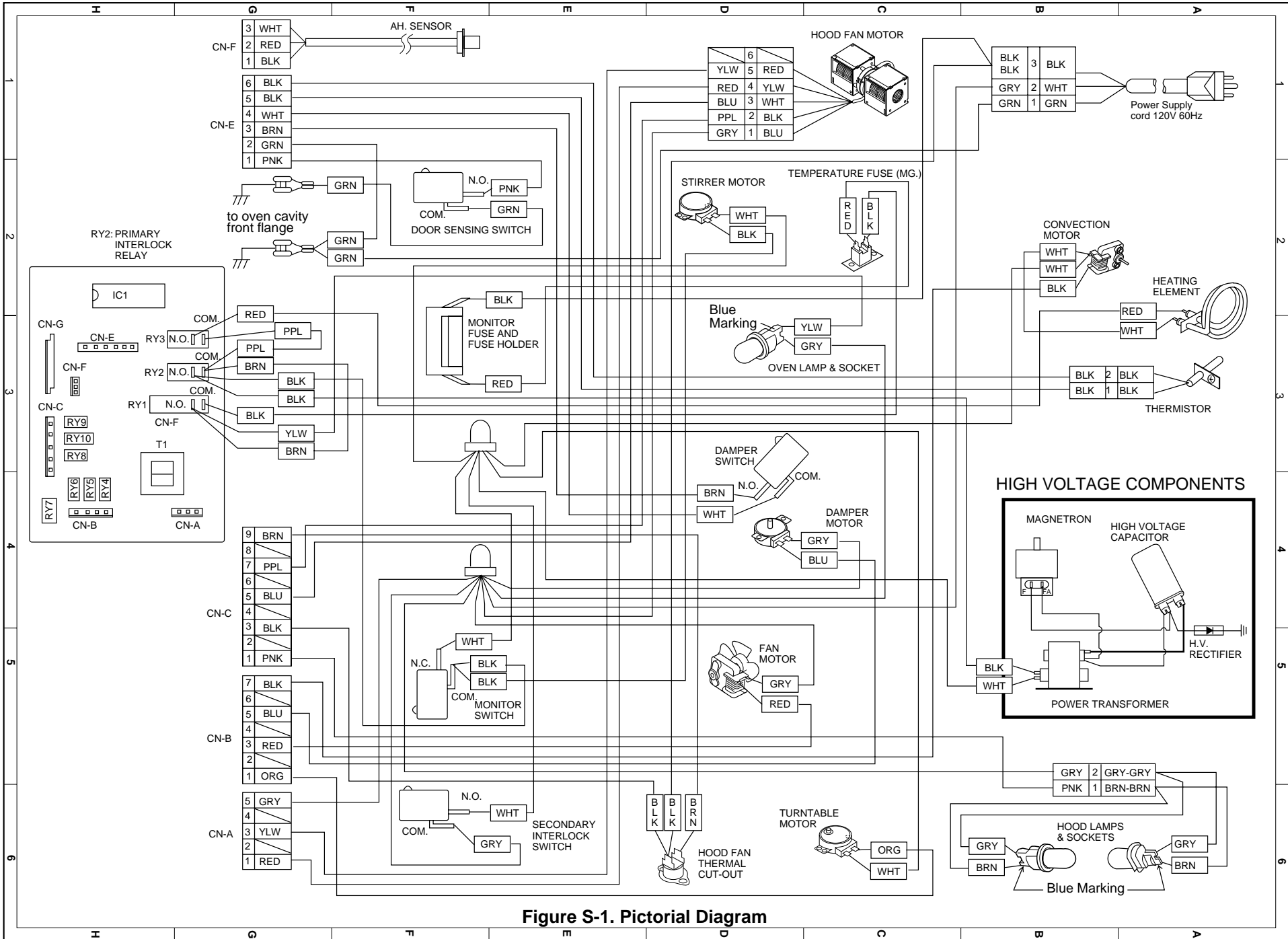

Figure S-1. Pictorial Diagram

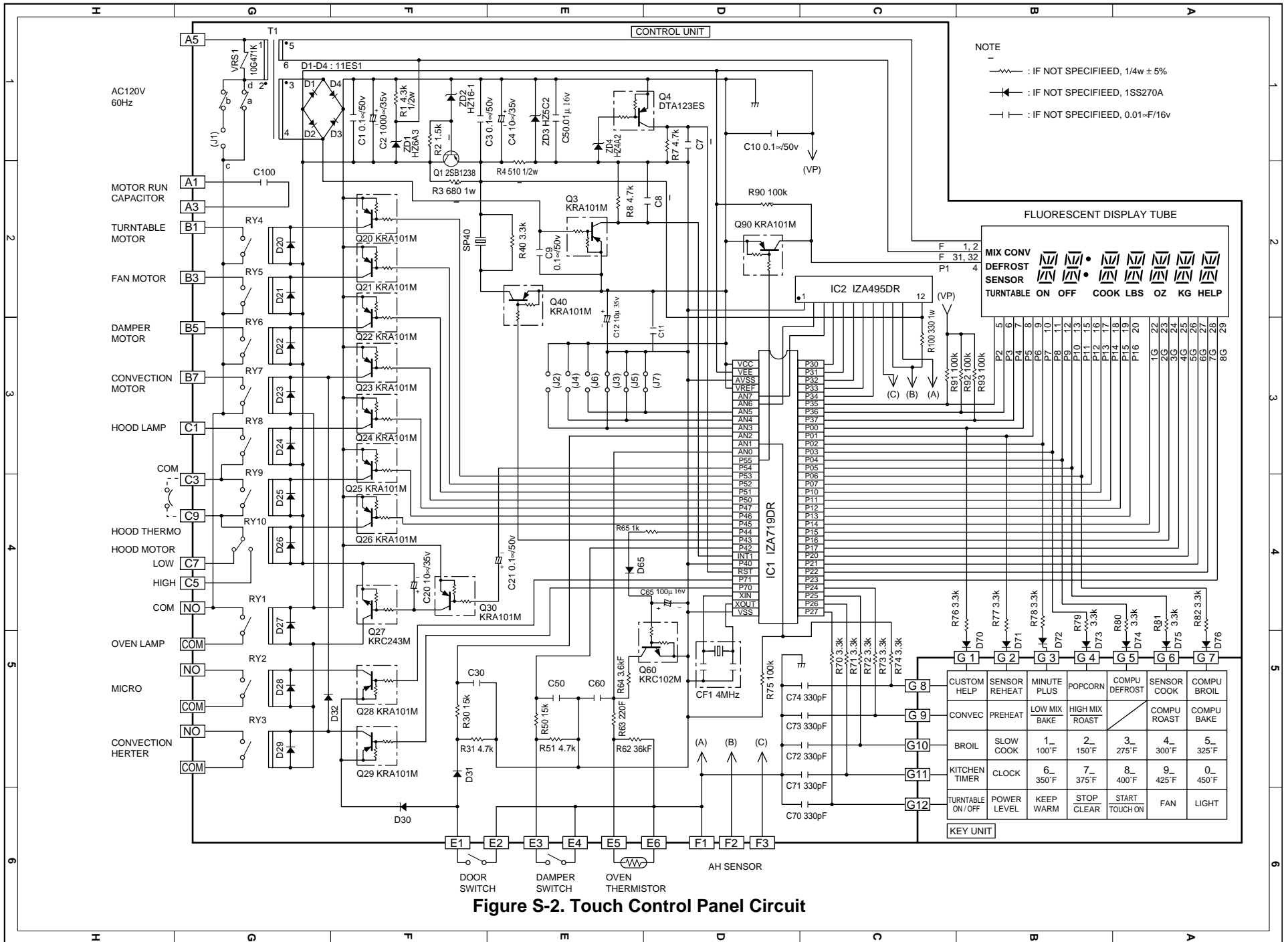

Figure S-2. Touch Control Panel Circuit

NOTE
 — : IF NOT SPECIFIED, 1/4w ±5%
 — : IF NOT SPECIFIED, 1SS270A
 — : IF NOT SPECIFIED, 0.01-F/16v

FLUORESCENT DISPLAY TUBE
 MIX CONV DEFROST
 SENSOR
 TURNTABLE ON OFF COOK LBS OZ KG HELP

G 1	G 2	G 3	G 4	G 5	G 6	G 7
CUSTOM HELP	SENSOR REHEAT	MINUTE PLUS	POPCORN	COMPU DEFROST	SENSOR COOK	COMPU BROIL
CONVEC	PREHEAT	LOW MIX BAKE	HIGH MIX ROAST	COMPU ROAST	COMPU BAKE	
BROIL	SLOW COOK	1_ 100°F	2_ 150°F	3_ 275°F	4_ 300°F	5_ 325°F
KITCHEN TIMER	CLOCK	6_ 350°F	7_ 375°F	8_ 400°F	9_ 425°F	0_ 450°F
TURNTABLE ON/OFF	POWER LEVEL	KEEP WARM	STOP CLEAR	START TOUCHON	FAN	LIGHT

PARTS LIST

Note: The parts marked "Δ" may cause undue microwave exposure.

The parts marked "*" are used in voltage more than 250V. "§" MARK: PARTS DELIVERY SECTION.

REF. NO.	PART NO.	§	DESCRIPTION	Q'TY	CODE
ELECTRIC PARTS					
1- 1	FH-DZB017MRY0	M	High voltage rectifier assembly	1	AM
1- 2	RC-QZA234WRE0	M	High voltage capacitor	1	AP
1- 3	QFS-TA013WRE0	M	Temperature fuse 150°C	1	AG
1- 4	RHET-A174WRE0	M	Convection heater	1	AZ
1- 5	RMOTDA211WRE0	M	Turntable motor	1	AQ
1- 6	RMOTDA241WRZZ	M	Stirrer motor	1	AG
1- 7	RTHM-B044MRE0	M	Thermal cut-out N.O. 60°C	2	AG
1- 8	RTRN-B070MRE0	M	Power transformer	1	BF
1- 9	RV-MZA255WRE0	M	Magnetron	1	BE
1-10	QFSHDB003MRE0	M	Fuse holder	1	AD
1-11	QSW-MA110WRE0	M	Secondary interlock, door sensing and damper switches	3	AE
1-12	FFS-BA016/KIT	M	Monitor switch with fuse assembly	1	AF
1-13	FACCD011MRE0	M	Power supply cord	1	AP
1-14	QSOCLB006MRE0	M	Hood lamp socket	2	AE
1-15	FH-HZA053WRE0	M	Thermistor	1	AP
1-16	QSOCLB006MRE0	M	Oven lamp socket	1	AE
1-17	FMOTEA362WRK0	M	Hood fan motor	1	BM
1-18	RMOTEA343WRE0	M	Convection motor	1	AX
1-19	RMOTEB032MRE0	M	Fan motor	1	AS
1-20	RLMPTA068WRE0	M	Hood lamp and oven lamp	3	AG
1-21	FDTCTA217WRKZ	M	AH sensor	1	AW
1-22	RMOTDA242WRZZ	M	Damper motor	1	AH
1-23	RR-WZA031WRE0	M	Noise resistor	1	AK

CABINET PARTS

2- 1	PFIL-B002MRE0	M	Grease filter	2	AF
2- 2	PDIF-B036MRF0	M	Hood exhaust louver	1	AV
2- 3	GDAI-B052MRP0A	M	Base plate right	1	AH
2- 4	GDAI-B039MRP0A	M	Base plate left	1	AF
2- 5	GCABUB101MRP0	M	Outer case cabinet	1	AY
2- 6	TMAPCB056MRR0	M	Schematic diagram	1	AB
2- 7	FANGKB013MRY0	M	Hood lamp glass assembly	1	AK
2-7-1	LANGQB049MRP0	M	Hood lamp glass angle	1	AG
2-7-2	PGLSPB004MRE0	M	Hood lamp glass	1	AH
2- 8	PCOVPB103MRT0	M	Base cover	1	AP
2- 9	HDECQB038MRF0A	M	Sash left	1	AK
2-10	LSTY-B010MRP0	M	Rear stay	1	AG

CONTROL PANEL PARTS

3- 1	DPWFB061MRU0	M	Control unit	1	BQ
3- 1A	QCNCMA227DRE0	J	3-pin connector CN-A	1	AC
3- 1B	QCNCMA230DRE0	J	4-pin connector CN-B	1	AC
3- 1C	QCNCMA234DRE0	J	5-pin connector CN-C	1	AC
3- 1D	QCNCMA267DRE0	J	6-pin connector CN-E	1	AC
3- 1E	QCNCMA237DRE0	J	3-pin connector CN-F	1	AD
3- 1F	QCNCWA030DRE0	J	12-pin connector CN-G	1	AE
3- 1G	RV-KXB003MRE0	M	Fluorescent display tube	1	AV
3- 1H	PTPEHB010MRE0	M	Tape 2mm	1	AB
C1	RC-KZA087DRE0	J	Capacitor 0.1 uF 50V	1	AB
C2	VCEAB31VW108M	J	Capacitor 1000 uF 35V	1	AF
C3	RC-KZA087DRE0	J	Capacitor 0.1 uF 50V	1	AB
C4,C2	VCEAB31VW106M	J	Capacitor 10 uF 35V	2	AB
C6	VCEAB31VW106M	J	Capacitor 10 uF 35V	1	AB
C7-8	VCKYD11CY103N	J	Capacitor 0.01 uF 16V	2	AH
C9-10	RC-KZA087DRE0	J	Capacitor 0.1 uF 50V	2	AB
C20	VCEAB31VW106M	J	Capacitor 10 uF 35V	1	AB
C21	VCEAB31HW104M	J	Capacitor 0.1 uF 50V	1	AM
C30,C5	VCKYD11CY103N	J	Capacitor 0.01 uF 16V	2	AH
C50,C11	VCKYD11CY103N	J	Capacitor 0.01 uF 16V	2	AH
C60	VCKYD11CY103N	J	Capacitor 0.01 uF 16V	1	AH
C70-74	VCKYD11HB331K	J	Capacitor 330 pF 50V	5	AA
C65	VCEAB31CW107M	J	Capacitor 100 uF 16v	1	AF
C100	RC-QZB014MRE0	M	Capacitor 7 uF 230V	1	AM
CF1	RCRS-A010DRE0	J	Ceramic resonator (CST4.00MGW)	1	AD

REF. NO.	PART NO.	§	DESCRIPTION	Q'TY	CODE
D1-4	VHD11ES1///-1	J	Diode (11ES1)	4	AB
D20-32	VHD1SS270A/-1	J	Diode (1SS270A)	13	AA
D65	VHD1SS270A/-1	J	Diode (1SS270A)	1	AA
D70-76	VHD1SS270A/-1	J	Diode (1SS270A)	7	AA
IC1	RH-IZA719DRE0	J	LSI	1	AW
IC2	RH-IZA495DRE0	J	IC	1	AL
Q1	VS2SB1238///-3	J	Transistor (2SB1238)	1	AA
Q3	VSKRA101M///-3	J	Transistor (KRA101M)	1	AB
Q4	VSDTA123ES/-3	J	Transistor (DTA123ES)	1	AA
Q20-26	VSKRA101M///-3	J	Transistor (KRA101M)	7	AB
Q27	VSKRC243M///-3	J	Transistor (KRC243M)	1	AB
Q28-30	VSKRA101M///-3	J	Transistor (KRA101M)	3	AB
Q40	VSKRA101M///-3	J	Transistor (KRA101M)	1	AB
Q60	VSKRC102M///-3	J	Transistor (KRC102M)	1	AB
Q90	VSKRA101M///-3	J	Transistor (KRA101M)	1	AB
R1	VRD-B12HF432J	J	Resistor 4.3k ohm 1/2W	1	AH
R2	VRD-B12EF152J	J	Resistor 1.5k ohm 1/4W	1	AA
R3	VRS-B13AA681J	J	Resistor 680 ohm 1W	1	AA
R4	VRD-B12HF511J	J	Resistor 510 ohm 1/2W	1	AB
R7-8	VRD-B12EF472J	J	Resistor 4.7k ohm 1/4W	2	AA
R30	VRD-B12EF153J	J	Resistor 15k ohm 1/4W	1	AA
R31	VRD-B12EF472J	J	Resistor 4.7k ohm 1/4W	1	AA
R40	VRD-B12EF332J	J	Resistor 3.3k ohm 1/4W	1	AA
R50	VRD-B12EF153J	J	Resistor 15k ohm 1/4W	1	AA
R51	VRD-B12EF472J	J	Resistor 4.7k ohm 1/4W	1	AA
R62	VRN-B12EK363F	J	Resistor 36k ohm 1/4W	1	AA
R63	VRN-B12EK221F	J	Resistor 220 ohm 1/4W	1	AB
R64	VRN-B12EK362F	J	Resistor 3.6k ohm 1/4W	1	AA
R65	VRD-B12EF102J	J	Resistor 1k ohm 1/4W	1	AA
R70-74	VRD-B12EF332J	J	Resistor 3.3k ohm 1/4W	5	AA
R75	VRD-B12EF104J	J	Resistor 100k ohm 1/4W	1	AA
R76-82	VRD-B12EF332J	J	Resistor 3.3k ohm 1/4W	7	AA
R90-93	VRD-B12EF104J	J	Resistor 100k ohm 1/4W	4	AA
R100	VRS-B13AA331J	J	Resistor 330 ohm 1W	1	AA
RY1-3	RRLY-B002MRE0	M	Relay (DU24D1-1P(M))	3	AH
RY4-9	RRLY-A075DRE0	J	Relay (OJE-SS-124LM)	6	AG
RY10	RRLY-B001MRE0	M	Relay (VE-24HSF-K)	1	AM
SP40	RALM-A014DRE0	J	Buzzer (PKM22EPT)	1	AG
T1	RTRNPB004MRE0	M	Transformer	1	AN
VRS1	RH-VZA032DRE0	J	Varistor (10G471K)	1	AE
ZD1	VHEHZ6A3///-1	J	Zener diode (HZ6A-3)	1	AC
ZD2	VHEHZ161///-1	J	Zener diode (HZ16-1)	1	AA
ZD3	VHEHZ5C2///-1	J	Zener diode (HZ5C-2)	1	AA
ZD4	VHEHZ4A2///-1	J	Zener diode (HZ4A-2)	1	AA
3- 2	FPNLCB417MRK0A	M	Control panel sub. assembly	1	BA
3- 2-1	FUNTKB361MRE0	M	Key unit	1	AT
3- 2-2	GMADIB023MRF0	M	Display window	1	AD
3- 2-3	MSPRTA050WRE0	M	Open button spring	1	AA
3- 2-4	JBTN-B130MRF0	M	Open button	1	AE
3- 2-5	JBTN-B131MRF0	M	Select button	1	AD
3- 2-6	LANGQB036MRP0	M	Key fixing	1	AL
3- 3	XEPSD30P10XS0	M	Screw; 3mm x 10mm	3	AA

OVEN PARTS

4- 1	FFTA-B004MRK0	M	Exhaust damper assembly	1	AM
4- 2	FROLPB020MRK0	M	Turntable support assembly	1	AS
4- 3	NTNT-B006MRE0	M	Turntable tray	1	AZ
4- 4	LANGKB010MRP0	M	Capacitor holder	1	BB
4- 5	FCOVBP002MRY0	M	Stirrer cover assembly	1	AM
4- 6	FFAN-B008MRK0	M	Stirrer fan assembly	1	AL
4- 7	PDUC-B053MRP0	M	Convection heater duct assembly	1	AT
4- 8	NCPL-B007MRF0	M	Coupling	1	AE
4- 9	NFANMB003MRP0	M	Convection motor fan	1	AE
4-10	LANGQB031MRP0	M	Convection motor angle	1	AF
4-11	PPACGB013MRE0	M	Turntable motor packing	1	AC
4-12	LBNDK0054WRE0	M	Heater mounting holder	2	AD
4-13	NFANMB004MRP0	M	Convection fan	1	AE

REF. NO.	PART NO.	§	DESCRIPTION	Q'TY	CODE
4-14	PHOK-B013MRF0	M	Latch hook	1	AG
4-15	FANGTB003MRY0	M	Unit mounting plate	1	AV
4-16	PFPF-B002MRE0	M	Heat protect L	1	AK
4-17	PPIFPB002MRE0	M	Coller	1	AD
4-18	PREFHB006MRP0	M	Heater cover L	1	AM
4-19	PDUC-B083MRP0	M	Hood intake duct L	1	AG
4-20	NFANPB005MRK0	M	Fan blade	1	AC
4-21	GBDYRB002MRP0	M	Back plate	1	AX
4-22	FDUC-B046MRK0	M	Fan duct	1	AM
4-23	LBSHC0037WRE0	M	Cord bushing	1	AB
4-24	FDUC-B050MRK0	M	Exhaust duct	1	AK
4-25	MLEVPB016MRF0	M	Open lever	1	AD
4-26	PCUSGB030MRP0	M	Cushion	1	AC
4-27	MCAMPB001MRF0	M	Damper cam	1	AC
4-28	PCUSGB032MRP0	M	Damper cushion	1	AC
4-29	PFPF-B001MRE0	M	Heat protect R	1	AD
4-30	PFTA-B003MRP0	M	Damper plate	1	AD
4-31	PREFHB004MRP0	M	Thermal cover R	1	AK
4-32	LANGQB033MRP0	M	Hood lamp angle	1	AM
4-33	PREFHB005MRP0	M	Thermal cover bottom	1	AK
4-34	LSTPPB024MRF0	M	Door stopper	1	AD
4-35	PCOVPB047MRP0	M	Oven lamp cover	1	AD
4-36	PCOVPB050MRP0	M	Heat protect top sheet	1	AK
4-37	PCUSGB027MRP0	M	Cushion	1	AA
4-38	PDUC-B056MRF0A	M	Hood exhaust duct	1	AY
4-39	PDUC-B057MRP0	M	Top duct	1	AN
4-40	PDUC-B058MRF0	M	Magnetron duct	1	AD
4-41	PDUC-B060MRP0	M	Hood intake duct R	1	AH
4-42	PFILWA035WRE0	M	Oven light screen	1	AF
4-43	PFPF-B003MRE0	M	Heat protect top	1	AE
4-44	PCUSUB018MRP0	M	Exhaust cushion A	1	AA
4-45	PCUSUB019MRP0	M	Exhaust cushion B	1	AA
4-46	PCUSUB020MRP0	M	Cushion	1	AA
4-47	PCUSUB024MRP0	M	Cushion	1	AD
4-48	PCUSGB035MRP0	M	Cushion	2	AA
4-49	PCUSUB046MRP0	M	Cushion	2	AA
4-50	PCUSUB047MRP0	M	Cushion	1	AA
4-51	PFPF-B004MRE0	M	Heat protect rear	1	AE
4-52	PFPF-B005MRE0	M	Heat protect bottom	1	AE

DOOR PARTS

5	CDORFB314MRK0	M	Door assembly, complete	1	BK
5- 1	DDORFB074MRY0	M	Door panel assembly	1	BB
5- 2	GWAKPB156MRF0	M	Door frame	1	AX
5- 3	PGLSPB049MRR0	M	Door glass front	1	AV
5- 4	GCOVHB031MRF0	M	Choke cover	1	AM
5- 5	LSTPPB025MRF0	M	Latch head	1	AE
5- 6	LSTPPB028MRF0	M	Glass stopper	1	AD
5- 7	MSPRTA046WRE0	M	Latch spring	1	AB
5- 8	PCUSUB022MRP0	M	Cushion	1	AC
5- 9	XCTSD40P08000	M	Screw : 4mm x 8mm	6	AA

MISCELLANEOUS

6- 1	CFZK-B131MRK0	M	Installation material assembly	1	AN
6-1-1	LBSHC0040MRE0	M	Grommet	1	AC
6-1-2	LX-BZ0195WRE0	M	Toggle screw	4	AC
6-1-3	LX-MZ0001WRE0	M	Cord holder	1	AC
6-1-4	XBRSD50P60000	M	Screw : 5mm x 60mm	2	AC
6-1-5	XOTSD40P12000	M	Screw : 4mm x 12mm	1	AA
6-1-6	XTSSD50P35000	M	Screw : 5mm x 35mm	6	AA
6-1-7	XWHS50-16300	M	Washer	2	AA
6- 2	TINSEB141MRR0	M	Installation instruction	1	AD
6- 3	TINSEB315MRK0	M	Operation manual	1	AD
6- 4	TINSKB018MRR0	M	Top template	1	AD
6- 5	TINSKB019MRR0	M	Wall template	1	AD
6- 6	QW-QZB011MRE0	M	High voltage wire A	1	AD
6- 7	TCADCB012MRR0	M	Cook book	1	AP
6- 8	FW-VZB166MRE0	M	Main harness A	1	AY
6- 9	UAMI-B011MRY0	M	High rack	1	AQ
6-10	UAMI-B010MRY0	M	Low rack	1	AP

REF. NO.	PART NO.	§	DESCRIPTION	Q'TY	CODE
6-11	FW-VZB077MRE0	M	Main harness C	1	AH
6-12	TCAUAA041WRR0	M	Caution label	1	AA
6-13	TCAUAB005MRR0	M	DHHS caution label	1	AA
6-14	TCAUAB045MRR0	M	Monitor caution label	1	AA

SCREWS,NUTS AND WASHERS

7- 1	XCPD40P08000	M	Screw : 4mm x 8mm	1	AA
7- 2	XOTSE40P10000	M	Screw : 4mm x 10mm	4	AA
7- 3	XCBSD30P08000	M	Screw : 3mm x 8mm	3	AA
7- 4	XBTSD40P08RV0	M	Screw : 3mm x 6mm	2	AA
7- 5	XCBSD30P08000	M	Screw : 3mm x 8mm	2	AA
7- 6	XBTWW40P06000	M	Screw : 4mm x 6mm	2	AA
7- 7	XOTSD40P12000	M	Screw : 4mm x 12mm	19	AA
7- 8	XOTSF40P10000	M	Screw : 4mm x 10mm	1	AA
7- 9	LX-BZ0208WRE0	M	Screw : 4mm x 8mm	2	AA
7-10	LX-BZB011MRE0	M	Unit mounting screw	2	AH
7-11	LX-CZA038WRE0	M	Special screw	4	AA
7-12	XCBWW30P08000	M	Screw : 3mm x 6mm	5	AA
7-13	LX-CZ0052WRE0	M	Special screw	2	AA
7-14	XCTWW40P08RV0	M	Screw : 4mm x 8mm	2	AA
7-15	XRES40-06000	M	E-ring	1	AA
7-16	XOTSD40P12000	M	Screw : 4mm x 12mm	2	AC
7-17	XCTWW40P08000	M	Screw : 4mm x 8mm	2	AA
7-18	LX-NZA002WRE0	M	Nut : 4mm x 3.2mm	1	AB
7-19	XWSUW40-10000	M	Spring Washer	1	AA
7-20	LX-BZA041WRE0	M	Screw : 4mm x 8mm	9	AA
7-21	XWHSD50-20120	M	Washer : 5mm x 2mm	1	AA
7-22	XWHUW40-08120	M	Washer : 4mm x 0.8mm	2	AA
7-23	XWHUW50-08120	M	Washer : 5mm x 0.8mm	1	AA
7-24	XOTSD40P08000	M	Screw : 4mm x 8mm	13	AA
7-25	XOTWW40P10000	M	Screw : 4mm x 10mm	8	AA
7-26	LX-CZB004MRE0	M	Hood louver screws	2	AA

HOW TO ORDER REPLACEMENT PARTS

To have your order filled promptly and correctly, please furnish the following information.

1. MODEL NUMBER 2. REF. NO. 3. PART NO. 4. DESCRIPTION

Order Parts from the authorized SHARP parts Distributor for your area.

Defective parts required return should be returned as indicated in the Service Policy.

OVEN AND CABINET PARTS

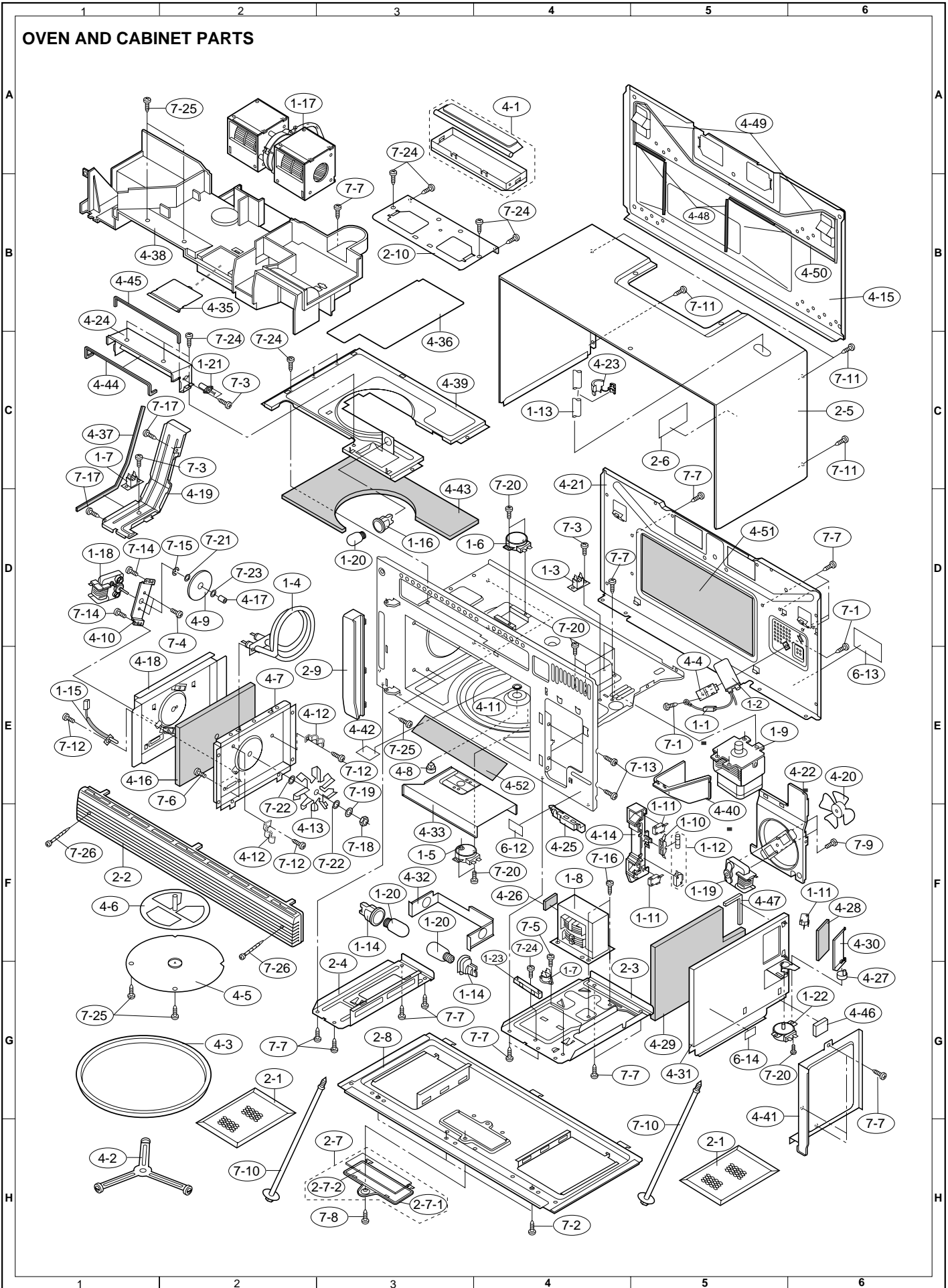

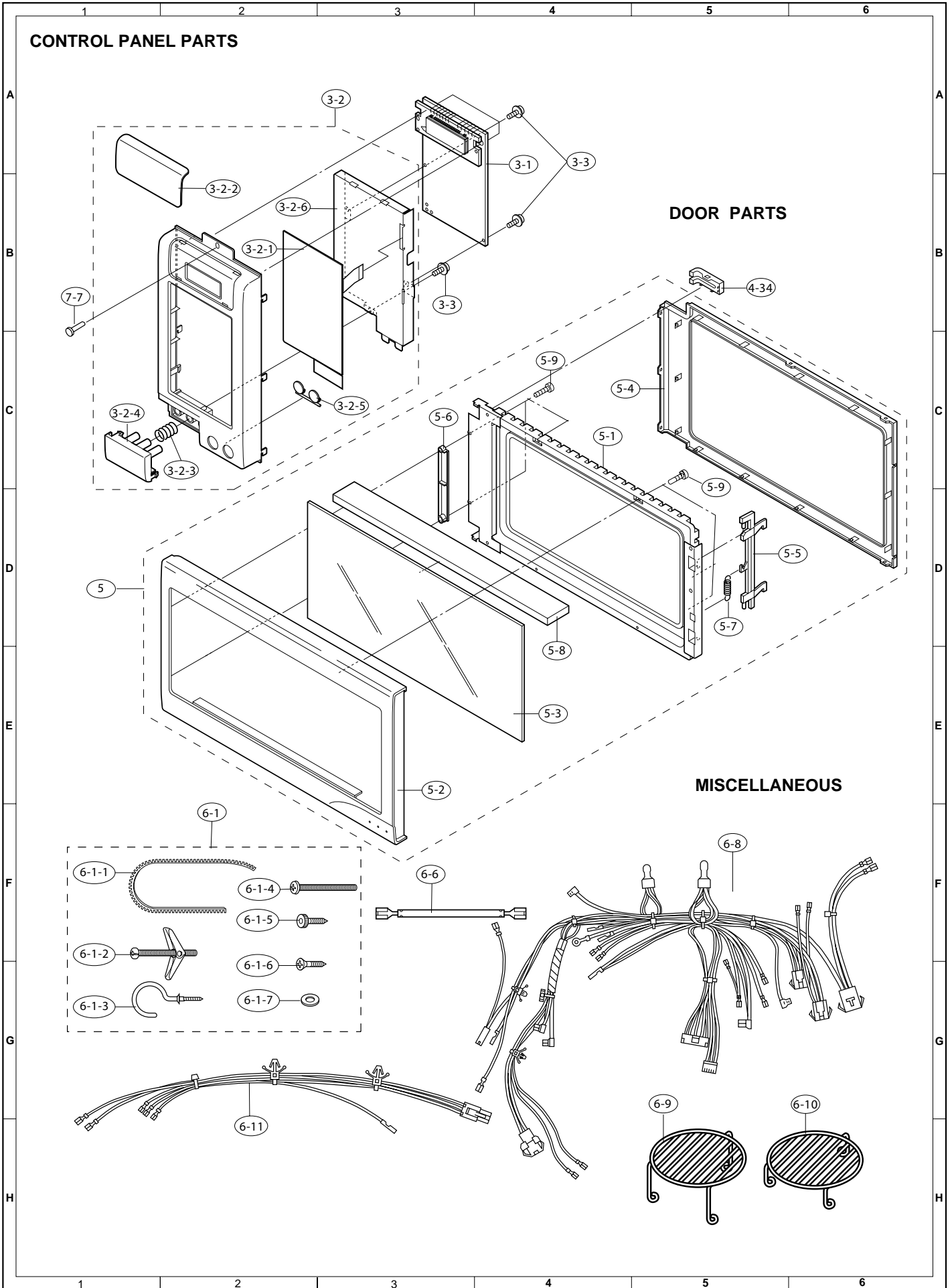

PACKING AND ACCESSORIES

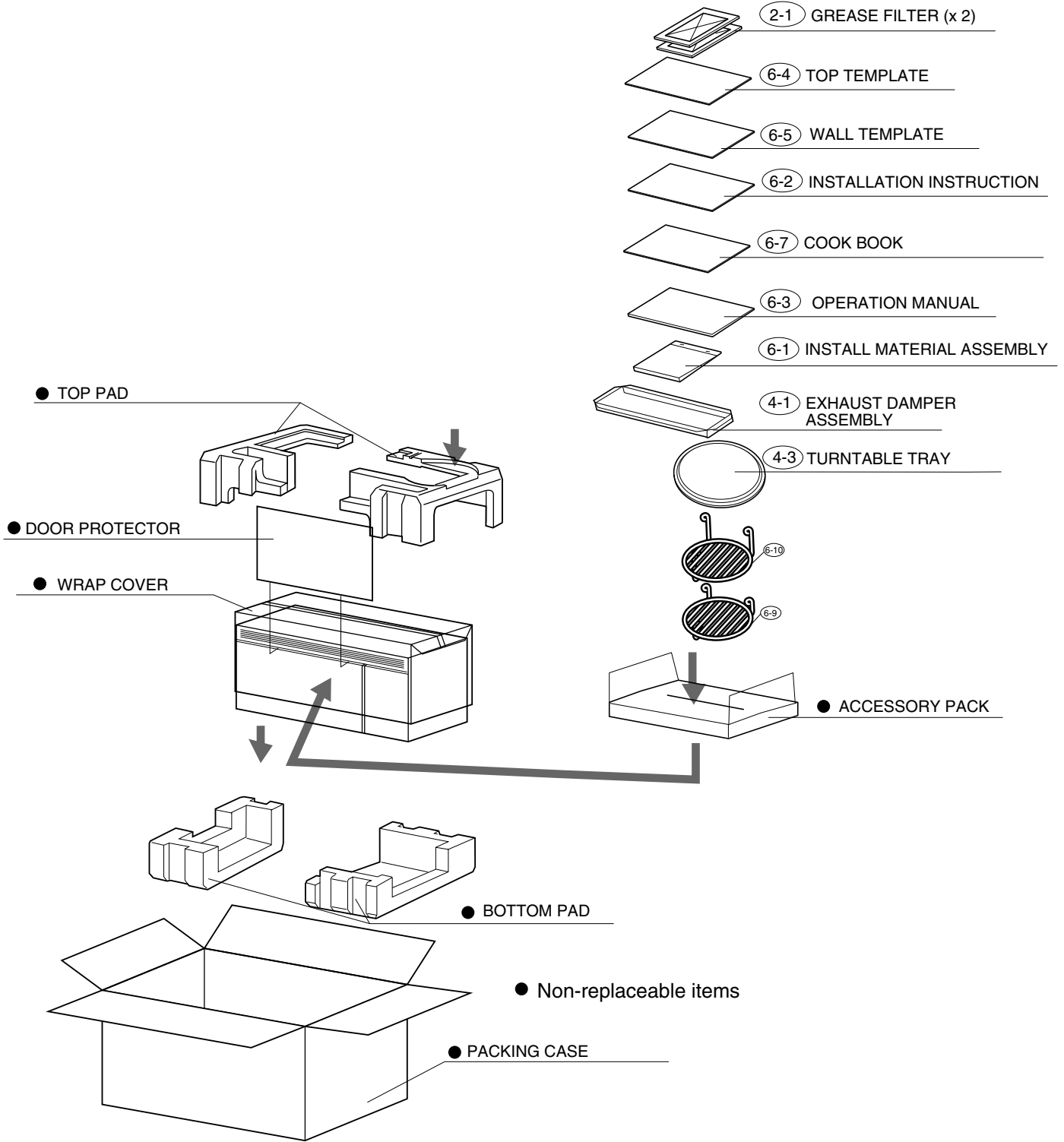

Notes

Notes

Notes

SHARP

COPYRIGHT © 2002 BY SHARP CORPORATION

ALL RIGHTS RESERVED.

No part of this publication may be reproduced, stored in retrieval systems, or transmitted in any form or by any means, electronic, mechanical, photocopying, recording, or otherwise, without prior written permission of the publisher.