

## Introduction

This manual provides information needed to operate and understand the vehicle and its components. More detailed information is contained in the *Owner's Warranty Information for North America* booklet, and in the vehicle's workshop and maintenance manuals.

Freightliner chassis are equipped with various chassis and driver controls. Not all of the information contained in this manual applies to every vehicle. If parts on your chassis differ from those shown, they may have been installed by the vehicle final-stage manufacturer.

The safety or performance of your vehicle could be adversely affected by the installation of nonstandard components. Note the limitations and specifications provided in the vehicle and chassis manuals, and consult Freightliner Custom Chassis Corporation before making any alterations to the chassis.

For your reference, keep this manual in the vehicle at all times.

**IMPORTANT:** Descriptions and specifications in this manual were in effect at the time of printing. Freightliner Custom Chassis Corporation reserves the right to discontinue models and to change specifications or design at any time without notice and without incurring obligation. Descriptions and specifications contained in this publication provide no warranty, expressed or implied, and are subject to revisions and editions without notice.

## Environmental Concerns and Recommendations

Whenever you see instructions in this manual to discard materials, you should first attempt to reclaim and recycle them. To preserve our environment, follow appropriate environmental rules and regulations when disposing of materials.

## Event Data Recorder

This vehicle is equipped with one or more devices that record specific vehicle data. The type and amount of data recorded varies depending on how the vehicle is equipped (such as the brand of engine, if an air bag is installed, or if the vehicle features a collision avoidance system, etc.).

## Customer Assistance Center

Having trouble finding service? Call the Customer Assistance Center at 1-800-385-4357 or 1-800-FTL-HELP. Call night or day, weekdays or weekends, for dealer referral, vehicle information, or breakdown coordination. Our people are knowledgeable, professional, and committed to keeping your vehicle moving.

## Reporting Safety Defects

If you believe that your vehicle has a defect that could cause a crash or could cause injury or death, you should immediately inform the National Highway Traffic Safety Administration (NHTSA) in addition to notifying Freightliner Custom Chassis Corporation.

If the NHTSA receives similar complaints, it may open an investigation, and if it finds that a safety defect exists in a group of vehicles, it may order a recall and remedy campaign. However, NHTSA cannot become involved in individual problems between you, your dealer, or Freightliner Custom Chassis Corporation.

To contact NHTSA, you may call the Vehicle Safety Hotline toll-free at 1-888-327-4236 (TTY: 1-800-424-9153); go to [www.safercar.gov](http://www.safercar.gov); or write to: Administrator, NHTSA, 400 Seventh Street, SW, Washington, DC 20590. You can also obtain other information about motor vehicle safety from [www.safercar.gov](http://www.safercar.gov).

Canadian customers who wish to report a safety-related defect to Transport Canada, Defect Investigations and Recalls, may telephone the toll-free hotline 1-800-333-0510, or contact Transport Canada by mail at: Transport Canada, ASFAD, Place de Ville Tower C, 330 Sparks Street, Ottawa, Ontario, Canada K1A 0N5.

For additional road safety information, please visit the Road Safety website at: [www.tc.gc.ca/roadsafety/menu.htm](http://www.tc.gc.ca/roadsafety/menu.htm).

# Foreword

---

© 1997-2007 Freightliner LLC. All rights reserved.

No part of this publication, in whole or part, may be translated, reproduced, stored in a retrieval system, or transmitted in any form by any means, electronic, mechanical, photocopying, recording, or otherwise, without the prior written permission of Freightliner LLC. For additional information, please contact Freightliner LLC, Service Systems and Documentation, P.O. Box 3849, Portland OR 97208-3849 U.S.A. or refer to [www.Freightliner.com](http://www.Freightliner.com) and [www.FreightlinerChassis.com](http://www.FreightlinerChassis.com).

# Contents

---

Chapter		Page
	Introduction, Environmental Concerns and Recommendations, Event Data Recorder, Customer Assistance Center, Reporting Safety Defects .....	Foreword
1	Vehicle Identification .....	1.1
2	Driver Controls and Instruments .....	2.1
3	Engines .....	3.1
4	Transmissions .....	4.1
5	Steering System .....	5.1
6	Brake System .....	6.1
7	Pretrip Inspection and Daily Maintenance .....	7.1
8	In an Emergency .....	8.1
9	Specifications .....	9.1
10	Towing .....	10.1
	Index .....	I.1

# 1

## Vehicle Identification

---

Vehicle Specification Label .....	1.1
Vehicle Identification Number (VIN) .....	1.1
EPA07 Exhaust Emissions .....	1.1

# Vehicle Identification

## Vehicle Specification Label

The vehicle specification label contains the name of the manufacturer, the month and year of manufacture, the certification statement, vehicle identification number, gross vehicle weight rating (GVWR), front and rear gross axle weight ratings (GAWRs), tire and wheel sizes, and the recommended maximum tire inflation pressures. See [Fig. 1.1](#).

INCOMPLETE VEHICLE IDENTIFICATION DATA

**FREIGHTLINER**  
A Subsidiary of FREIGHTLINER LLC

INCOMPLETE VEHICLE MANUFACTURED BY:  
FREIGHTLINER CUSTOM CHASSIS CORPORATION  
GAFFNEY, SOUTH CAROLINA 29341

INCOMPLETE VEHICLE DOM:  
VIN:

GVWR/PNBV:  
GAWR/PNBE:  
FRONT =  
WITH TIRES RIMS  
PRESSURE = (COLD)

FIRST INTMD =  
WITH TIRES RIMS  
PRESSURE = (COLD)

REAR =  
WITH TIRES RIMS  
PRESSURE = (COLD)

VEHICLE TYPE:  
MODEL:

NOTE: ALL WEIGHTS LISTED IN kg (lb)  
PRESSURES LISTED IN kPa (psi)

OVERSPEEDING OR OVERLOADING WILL  
VOID WARRANTY. THE ABOVE DATA  
REPRESENTS ORIGINAL EQUIPMENT.

09/11/2002 f080123

**Fig. 1.1, Vehicle Specification Label**

On incomplete vehicles, it is the responsibility of the final-stage manufacturer to complete the vehicle and label it for compliance with the Federal Motor Vehicle Safety Standards.

## Vehicle Identification Number (VIN)

The chassis vehicle identification number (VIN) is permanently attached to the chassis. See [Fig. 1.2](#). On VCL chassis models, the VIN label is mounted above the upper-left corner of the radiator. On XC

chassis models, the VIN label is mounted above the upper-right corner of the side radiator. On front engine models, the VIN label is mounted to the right of the radiator on the front of the frontwall. The last six digits are the chassis serial number.

**NOTE:** Always include the chassis serial number (last six digits of the VIN) when communicating to Freightliner LLC.

## EPA07 Exhaust Emissions

To meet January 2007 emissions regulations, vehicles with engines manufactured after January 1, 2007, are equipped with an emission after-treatment device. There is a warning label (placement will vary by bodybuilder), for two important new warning indicators in the driver's message display, that pertain to the aftertreatment system. See [Fig. 1.3](#).

For details of the after-treatment system warning indicators, see *EPA07 After-Treatment System (ATS)*, [Chapter 3](#), of this manual.

It is a violation of federal law to alter exhaust plumbing or after-treatment in any way that would bring the engine out of compliance with certification requirements. (Ref: 42 U.S.C. S7522(a) (3).) It is the owner's responsibility to maintain the vehicle so that it conforms to EPA regulations.

# Vehicle Identification

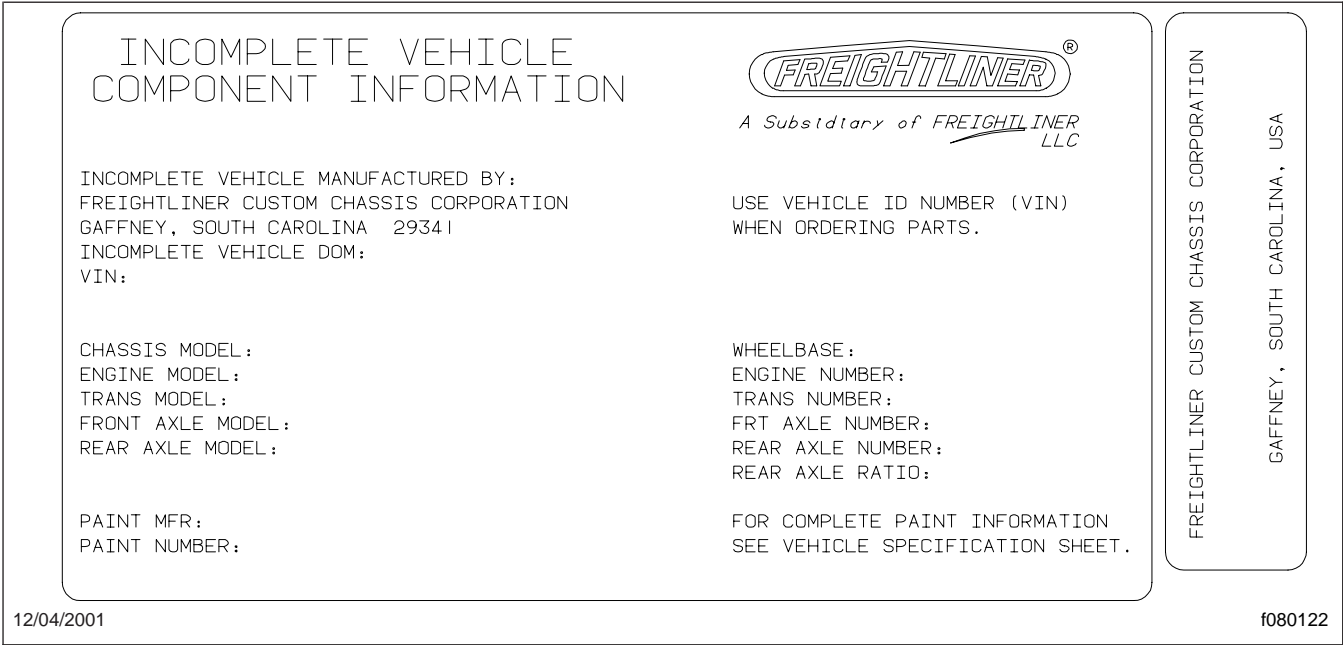

Fig. 1.2, Vehicle Identification Number (VIN) Label, Typical

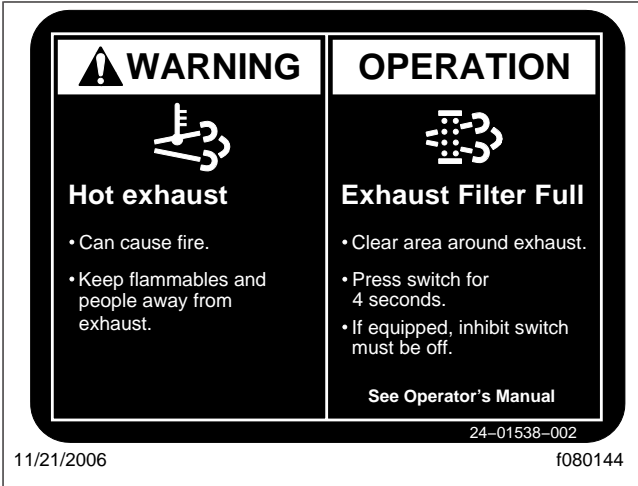

Fig. 1.3, EPA07 Warning Label

# 2

## Driver Controls and Instruments

---

Instrument Panel .....	2.1
Controls .....	2.1
SmartWheel (optional) .....	2.7
Warning and Indicator Lights .....	2.9
Instruments .....	2.10
Light Bar Control Unit (LBCU) .....	2.14
Multiple Module Data Computer (MMDC) .....	2.20
Instrumentation Control Unit (front-engine diesel chassis) .....	2.28

# Driver Controls and Instruments

## Instrument Panel

On XC, XCS, and VCL chassis vehicles equipped with System III electrical wiring, the warning and indicator light module (System III instrumentation) is located on the instrument panel and contains all of the standard and optional warning and indicator lights.

System III instrumentation includes a speedometer and a tachometer. A digital odometer display is located in the speedometer and a digital tripmeter display is located in the tachometer.

The odometer and the tripmeter can both display either English or metric values (miles or kilometers). A trip reset switch is located on the dash panel. If the switch is depressed for more than four seconds, both displays will cycle between English and metric values. At the left sides of the displays, a triangle will point to either an "m" or a "k" depending on which scale is selected.

To reset the tripmeter, depress the switch for less than four seconds. The tripmeter resets to either 0 miles or 0 kilometers. The display indicates in one tenth (mile or kilometer) increments, depending on the scale selected.

**NOTE:** Beginning with 2002 model year vehicles, a single odometer/tripmeter display is installed. Press the trip reset switch for less than four seconds to cycle the display between odometer and tripmeter modes. Press the switch for more than four seconds (in tripmeter mode) to reset the tripmeter. Press the switch for more than four seconds (in odometer mode) to cycle the display between English and metric values.

Up until December 31, 2006 the warning and indicator lights are a mixture of ISO icons and lettering. Since January 2007, ISO icons are used for all standard warning and indicator lights.

## Controls

### Ignition Switch and Key

The ignition switch can be turned to four positions: ACCESSORY, OFF, ON, and START. See [Fig. 2.1](#).

The key can be inserted and removed only from the OFF position. The headlights (low beams), brake lights, fog lights, dome lights, clearance lights, turn

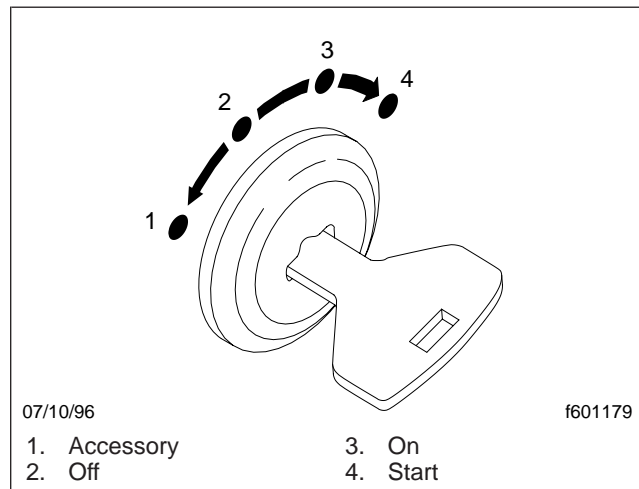

**Fig. 2.1, Ignition Switch**

signals, hazard warning lights, and parking lights operate with the ignition switch in the OFF position, regardless of whether the key is inserted.

**NOTE:** In the ACCESSORY position (the key is turned fully counterclockwise) the electric gauges will not operate.

Turn the key fully clockwise to the START position only when starting the engine. When the engine starts, release the key. When released, the key will rotate counterclockwise to the ON position.

In the ON position (key turned 45 degrees clockwise), all electrical systems are operable. The warning lights and the buzzer for low air pressure and low oil pressure operate until the engine is started and minimum pressures are built up.

### Headlight Switches and Panel Lights (models built from August 2003, on)

The control knob for the headlights, side marker lights, taillights, parking lights, license plate lights, and panel lights is located on the instrument panel. See [Fig. 2.2](#). The headlight control knob used for models built after August 2003 operates as follows:

- All lights are OFF if the control knob is turned to the left position.
- If the knob is in the middle position, all lights are on except the headlights.
- If the knob is in the right position, all lights including the headlights are on.



- If the knob is pulled out, all lights including the fog lights are on.

A separate dash panel dimmer control adjusts dash panel brightness. Turn the knob upwards to increase the panel brightness, and down to dim the light. See [Fig. 2.2](#).

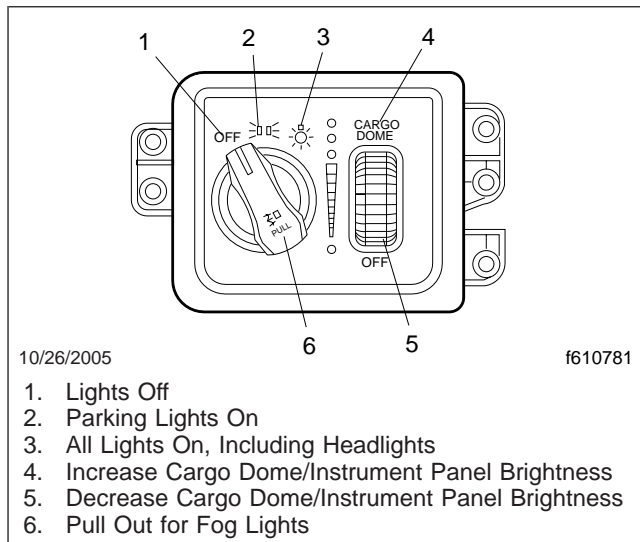

**Fig. 2.2, Light Control Knob (RV models built from August 2003, on)**

## Headlight Switches and Panel Lights (models built before August 2003)

The control knob for the headlights, side marker lights, taillights, parking lights, license plate lights, and panel lights is located on the instrument panel. See [Fig. 2.3](#). Control knob positions are as follows:

- All lights are off if the knob is pushed all the way in.
- If pulled out to the first stop, all lights are on except the headlights.
- If pulled all the way out, all lights including the headlights are on.

A separate dash panel dimmer control adjusts dash panel brightness. See [Fig. 2.4](#). Turn the knob to the right to brighten the panel lights or to the left to dim them.

The high-beam headlights are activated by pulling the turn signal lever toward the driver. See [Fig. 2.5](#). When the headlights are on high beam, the high-beam indicator light comes on in the instrument

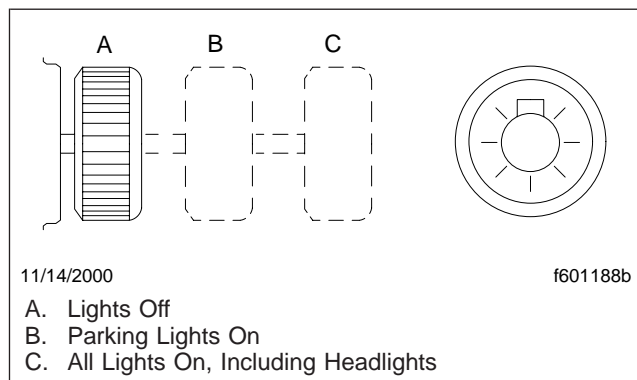

**Fig. 2.3, Light Control Knob (RV models built before August 2003)**

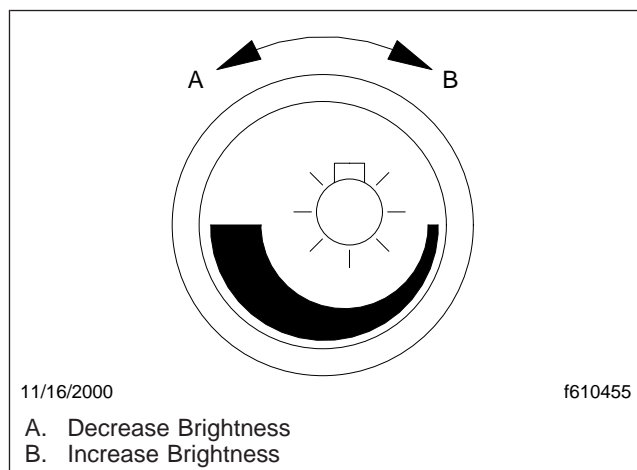

**Fig. 2.4, Panel Light Dimmer Control (RV models built before August 2003)**

panel. The ignition switch must be in the ON position for the high beams to operate.

## Interrupt Switch (optional)

A spring-loaded interrupt switch temporarily deactivates the marker lights and taillights. With the vehicle lights on, raise and release the interrupt switch to briefly turn off the marker lights and taillights.

## Parking Brake Controls

All pneumatic braked vehicles are equipped with a diamond-shaped parking brake control knob. See [Fig. 2.6](#). Pull the knob to apply the parking brake. In air brake systems, before the parking brake can be released, the air pressure in either brake system

# Driver Controls and Instruments

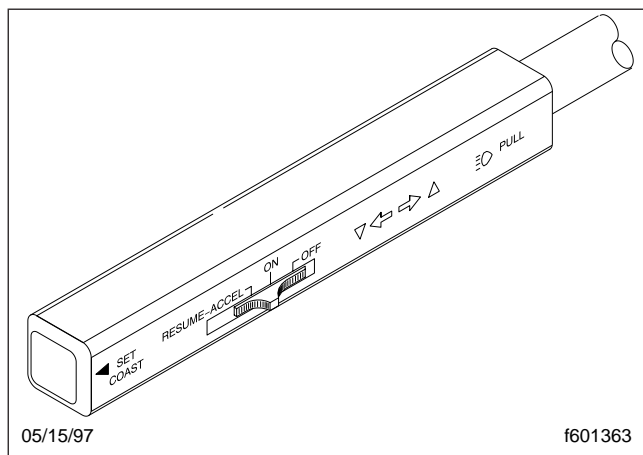

Fig. 2.5, Turn Signal Lever, Douglas Steering Column

must be at least 65 psi (448 kPa). See [Chapter 6](#) for detailed operating instructions.

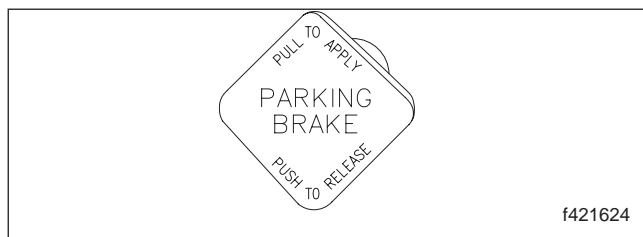

Fig. 2.6, Parking Brake Control Knob



**If the vehicle is equipped with an air suspension system, do not move the vehicle with the air suspension deflated. Doing so could result in a loss of vehicle control, possibly causing personal injury and property damage.**

NOTE: Chassis built with an air suspension dump option have an automatic feature that will not allow the suspension to be deflated unless the parking brakes are set. The suspension will automatically inflate when the parking brakes are released.

## Auto-Apply Parking Brake

The auto-apply parking brake is electronically controlled and set by pressing "Pb" on the shift selector. To release the parking brake, depress the service brake and shift from the "Pb" position to any drive

gear. See [Chapter 6](#) for detailed operating instructions. See [Fig. 2.13](#).

## Turn Signal Lever

The turn signal lever is mounted on the steering column. See [Fig. 2.5](#) and [Fig. 2.7](#). Push the lever counterclockwise to turn on the left turn signal; push it clockwise to turn on the right turn signal. When one of the turn signals is on, a green turn signal indicator light flashes at either the far-left or far-right side of the warning and indicator light panel. When the turn is completed, the signal will cancel and the lever will return to the neutral position.

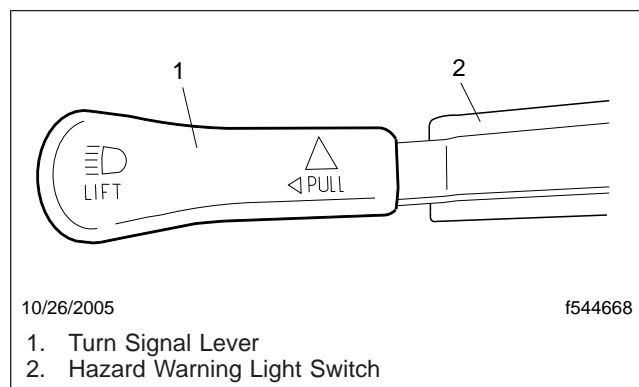

Fig. 2.7, Turn Signal Lever, TRW Steering Column

## Hazard Warning Lights (models built from July 2002, on)

To activate the hazard warning lights on RV models built after July 2002, pull out the hazard warning light switch located under the turn signal switch. See [Fig. 2.8](#). When the switch is pulled out, all of the turn signal lights and both of the indicator lights on the control panel will flash. To cancel the hazard warning lights, move the turn signal switch up or down.

## Hazard Warning Lights (models built before July 2002)

Pull out the hazard warning light switch on the steering column to activate the hazard warning lights. See [Fig. 2.9](#). The hazard warning light switch is located on the bottom of the steering column. When the switch is pulled out, all of the turn signal lights and both of the indicator lights on the control panel will flash. To cancel the warning lights, push the switch in.

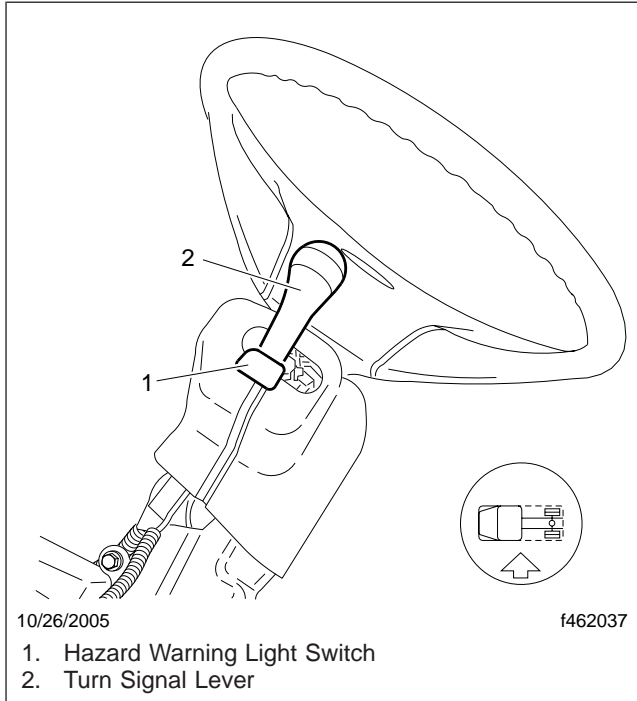

**Fig. 2.8, Hazard Warning Light Switch Location (RV models built after July 2002)**

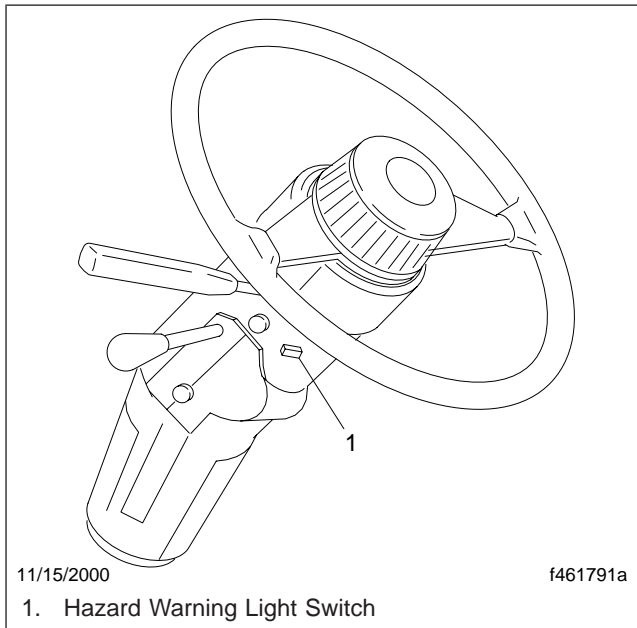

**Fig. 2.9, Hazard Warning Light Switch Location (RV models built before July 2002)**

## Allison Automatic Transmissions

Allison automatic transmissions are controlled by an electronic control unit (ECU). The ECU processes information from sensors, pressure switches, and the shift selector to automatically control the transmission according to programmed specifications. See [Fig. 2.10](#), and [Fig. 2.11](#). See [Chapter 4](#) for complete transmission operating instructions.

Later vehicles may be equipped with an Arens shift-by-wire (SBW) push-button shift selector. See [Fig. 2.12](#).

**NOTE:** SBW Allison 1000/2400 series automatic transmissions have a Park (P) position and SBW Allison 2000 series transmissions do not. The shift selectors appear the same except that there is no Park (P) position button on the series 2000 selector. See [Chapter 4](#) for complete transmission operating instructions.

SBW Allison 2100 series automatic transmissions have a park brake (Pb) position button on the transmission selector. See [Fig. 2.13](#).

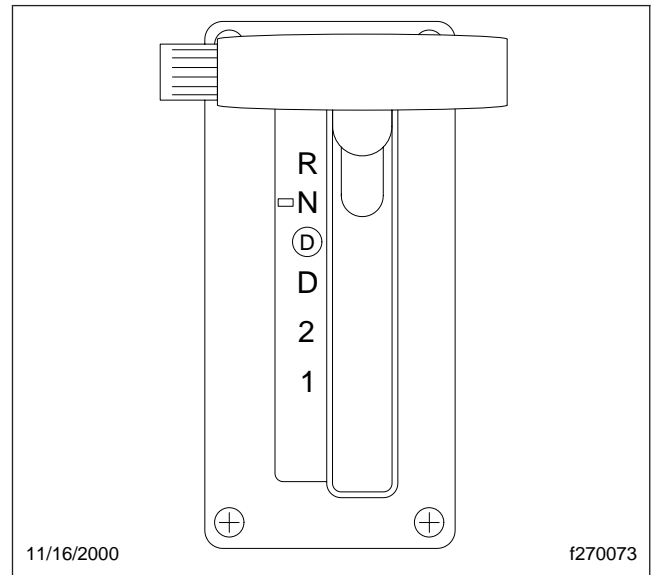

**Fig. 2.10, Allison 2000, 2000 MH Shift Selector Lever (six positions)**

# Driver Controls and Instruments

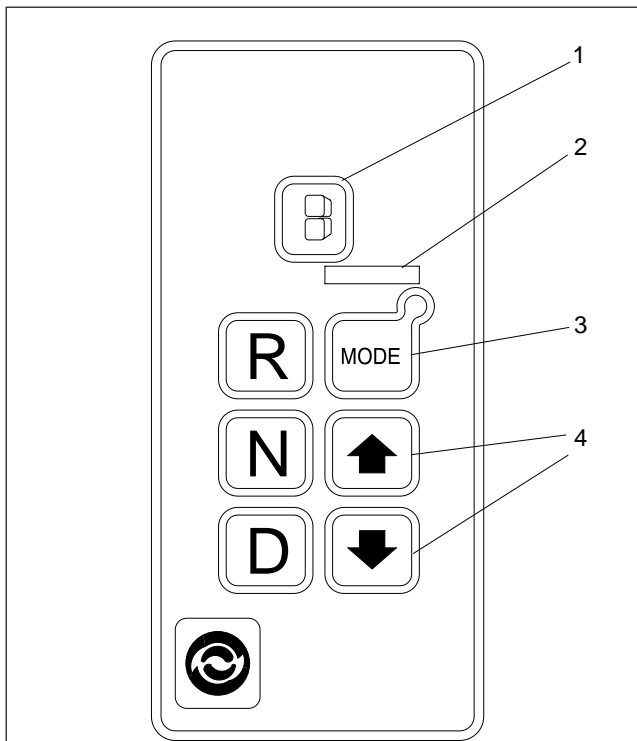

11/16/2000

f270113a

NOTE: The number displayed on the Digital Display button is the highest forward range available in the selected position. Visually check to confirm the range selected. If the display is flashing, the shift is inhibited.

1. Digital Display
2. Mode ID
3. Mode Indicator (LED)
4. Push Simultaneously for Diagnostic Mode and Fluid Level Check (optional)

Fig. 2.11, Allison WTEC III Shift Selector

## Cruise Control System



**WARNING**

Do not use the cruise control system when driving conditions do not permit maintaining a constant speed, such as in heavy traffic or on roads that are winding, icy, snow covered, slippery, or roads with a loose driving surface. Failure to follow this precaution could cause a collision or loss of vehicle control, possibly resulting in personal injury or property damage.

If the cruise control is column-mounted, it is operated by two switches on the turn signal lever. See

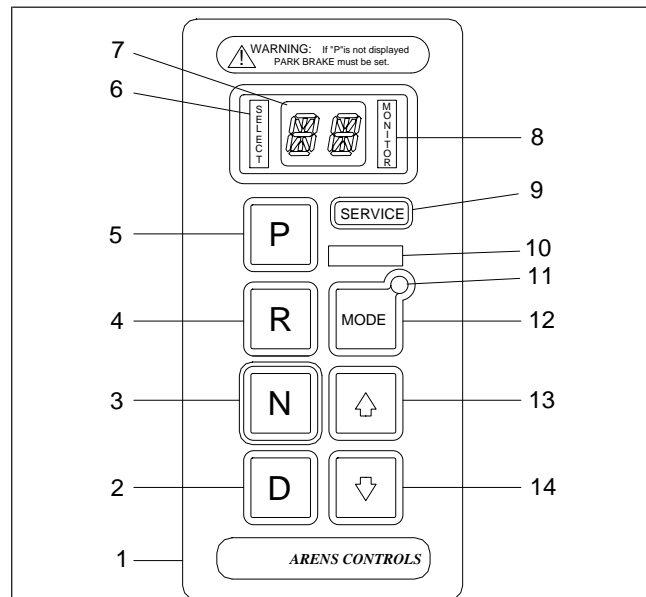

04/02/2003

f270122

- |                                  |                         |
|----------------------------------|-------------------------|
| 1. SBW Shift Selector            | 8. Monitor Display      |
| 2. Drive (D) Button              | 9. Service Display      |
| 3. Neutral (N) Button            | 10. Mode Function Label |
| 4. Reverse (R) Button            | 11. Mode Light          |
| 5. Park (P) Button               | 12. Mode Button         |
| 6. Select Display                | 13. Upshift Button      |
| 7. Select/Monitor Display Window | 14. Downshift Button    |

Fig. 2.12, SBW Push-Button Shift Selector

Fig. 2.14. A RESUME-ACCEL/ON/OFF switch allows the driver to select cruise control, drive with the pedal, accelerate while in cruise control, or resume cruise speed after slowing down. A spring-loaded SET COAST switch allows the driver to select the cruise speed or temporarily disable the cruise control to reduce speed.

If the cruise control is steering wheel-mounted, it is operated by two switches on the steering wheel. A Resume/Set Accel/Coast switch allows the driver to select cruise control, accelerate while in cruise control, temporarily disengage cruise control, or resume cruise speed after slowing down. The On/Off switch activates or turns off the cruise control function.

The system can also be used for throttle control when the vehicle is parked. See Chapter 3 for detailed operating instructions.

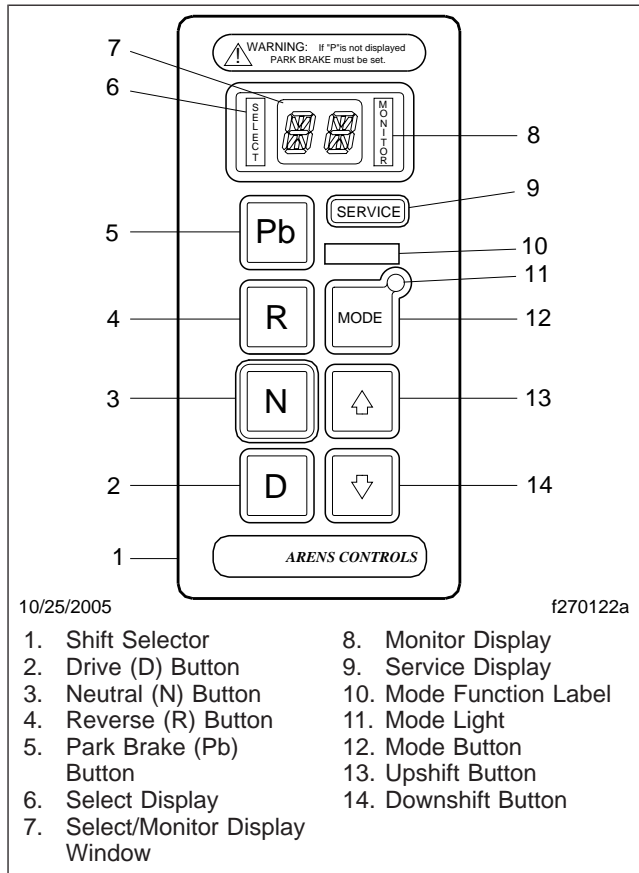

**Fig. 2.13, SBW Push-Button Shift Selector with Park Brake (Pb) Button (MC chassis)**

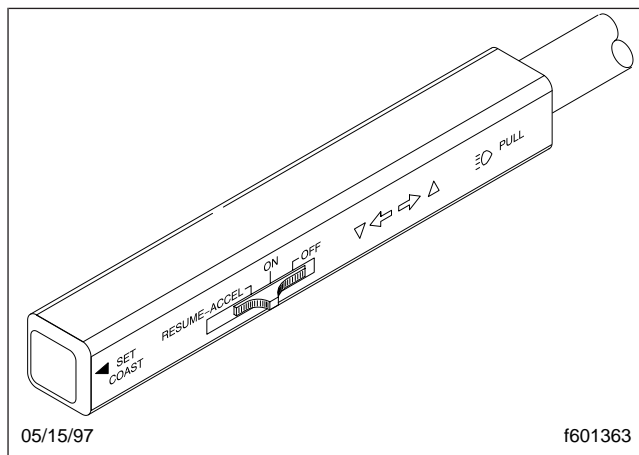

**Fig. 2.14, Cruise Control, Column-Mounted**

**NOTE:** On vehicles equipped with the optional SmartWheel, the cruise control switches are located on the left SmartWheel switch panel. See [Chapter 3](#) for additional information.

## Tag Axle Suspension Dump Switch (optional)

The tag axle suspension is a non-liftable, full-time suspension designed to increase the Gross Vehicle Weight Rating (GVWR). It is used when the rear suspension/axle will be loaded to a weight greater than 20,000 lb (9072 kg). Under certain conditions, air can be exhausted from the air springs to improve maneuverability or traction on the rear axle via the tag axle suspension dump switch.

The tag axle suspension dump switch is operated by a three-position, dash-mounted rocker switch. See [Fig. 2.15](#). The manual "TAG DUMP" mode is activated by pressing and holding the rocker switch all the way in. The "AUTO DUMP" mode is activated automatically during reverse gear applications when the rocker switch is placed in the middle (level) position. When you depress and hold the bottom of the rocker switch, the tag axle suspension dump switch is placed in the "OFF" (down) position, and the "TAG DUMP" mode is inactive.

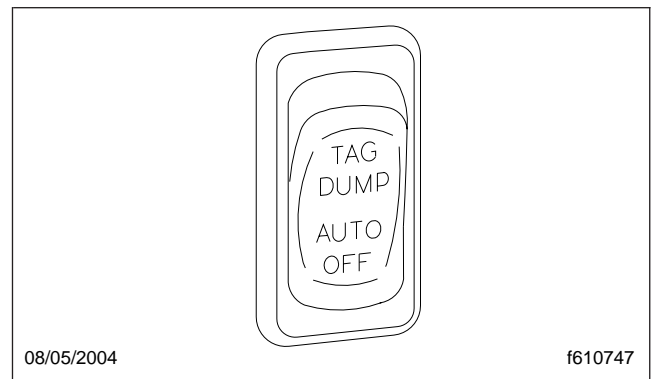

**Fig. 2.15, Tag Axle Suspension Dump Switch**

If the vehicle exceeds a speed of 8 mph (13 km/h) while the operator is holding the switch in the "TAG DUMP" position, the tag axle suspension dump switch control system will override the "TAG DUMP" mode and the tag suspension air springs will be re-filled.

**IMPORTANT:** The tag axle suspension dump switch feature must be cycled on and off of the

# Driver Controls and Instruments

"TAG DUMP" position if an override event occurs while the switch is held in the "TAG DUMP" position.

## Tilt/Telescope Steering Column

If equipped with a Douglas tilt/telescope steering column, pull the lever upward to change the position of the wheel. See [Fig. 2.16](#). Push the lever downward to extend or retract the column. Release the lever to lock the position. See [Chapter 5](#) for more information.

If equipped with a TRW tilt/telescope steering column, depress and hold the foot pedal to unlock the column. Tilt and/or telescope the column to the desired position. Release the pedal to lock the column in place. See [Chapter 5](#) for more information.

### **WARNING**

**Do not adjust the steering wheel while the vehicle is in motion. This could cause reduced vehicle control, resulting in serious personal injury.**

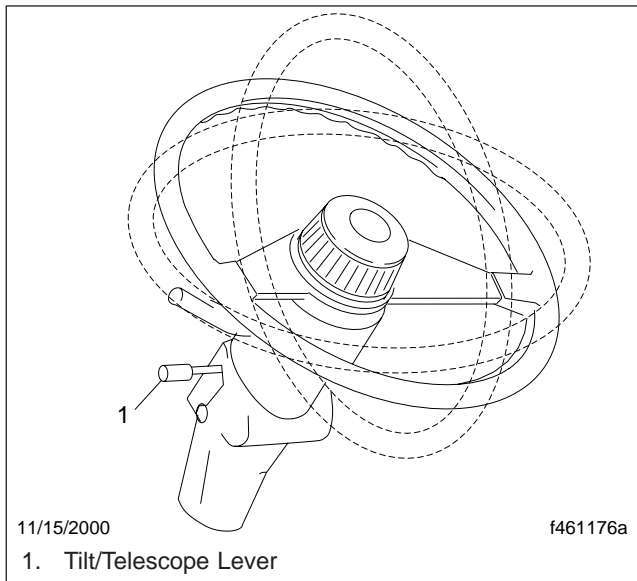

**Fig. 2.16, Douglas Tilt/Telescope Steering Column (typical)**

## Electric Horn

To sound the electric horn, push the button in the center of the steering wheel.

## Backup Alarm (optional)

An optional backup alarm, supplied with the chassis and installed by the body builder, sounds when Reverse (R) gear is engaged. Check the operation of the backup alarm daily (if so equipped).

## VCL Chassis Dash Switches

Standard VCL chassis dash switches include two rocker switches, Axle Lift and Pedal Move, and two paddle switches, Engine Brake On/Off and Engine Brake Lo/Med/Hi. An ATC (automatic traction control) Norm/Spin rocker switch is optional.

## After-Treatment System (ATS) Regen Connector

A regen connector is located under the dash with which the driver can control two states. These include:

- Request regeneration
- Default (automatic regeneration)

The function of the connector will vary by the engine make and model in the vehicle. See the engine operation manual for details.

## SmartWheel (optional)

The optional SmartWheel steering wheel control system allows control of the horn, headlamp and marker lamp interrupt, cruise control functions, and windshield wiper functions from steering wheel-mounted switch panels. See [Fig. 2.17](#) and [Fig. 2.18](#).

## Horn

The horn bar extends across the center of the steering wheel. Press the horn bar to sound the horn.

## Headlamp Interrupt

If the headlamps are on, press and hold the headlamp interrupt switch to turn them off. If the headlamps are off, press and hold the switch to turn them on.

**NOTE:** The headlamps will remain off or on only as long as the switch is being pressed.



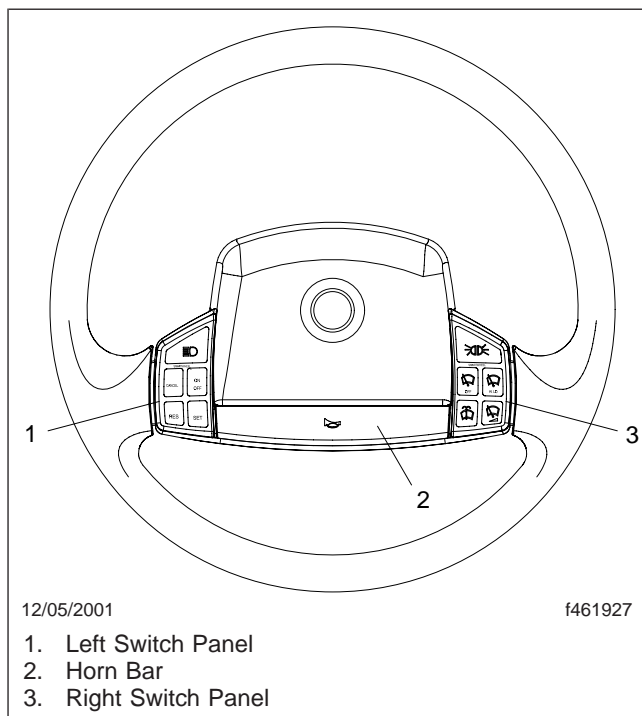

**Fig. 2.17, SmartWheel**

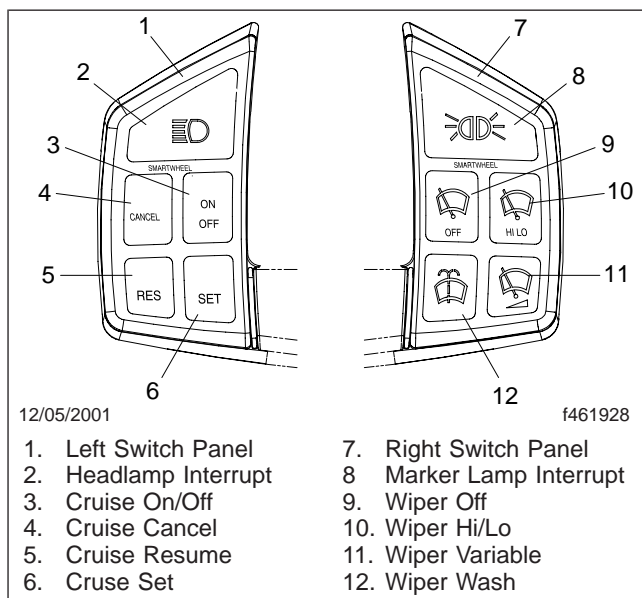

**Fig. 2.18, SmartWheel Switch Panels**

## Marker Lamp Interrupt

If the marker lamps are on, press and hold the marker lamp interrupt switch to turn them off. If the marker lamps are off, press and hold the switch to turn them on.

**NOTE:** The marker lamps will remain off or on only as long as the switch is being pressed.

## Windshield Wipers

**NOTE:** Activating any of the wiper switches causes the headlamps to come on. To turn the headlamps off, turn the dashboard headlamp switch on and then off.

## Wiper Wash

Press the wiper wash switch to activate the wiper wash pump.

**NOTE:** The pump will operate only as long as the switch is pressed. If you selected either the HI/LO or variable switch previously, the wipers will continue to run in that mode when you release the switch.

## Wiper Hi/Lo

Press the wiper HI/LO switch to activate the wipers at low speed. Press the switch again to activate the high speed. Pressing the switch once again will cause the wipers to cycle between high and low speed with each press of the switch.

## Wiper Variable

Press the wiper variable switch to activate the wipers for one low-speed wipe.

**NOTE:** Press the switch again within approximately 30 seconds and a second low-speed wipe will occur. The low-speed wipers will continue to activate at the interval determined by the time between the last two presses of the switch. Additional presses of the switch will shorten the interval. The variable mode will cancel if you select any other wiper mode.

## Wiper Off

Press the wiper OFF switch to cancel all operations of the wipers. Turning the ignition switch to the OFF

# Driver Controls and Instruments

position has the same effect of cancelling all wiper operations.

## Warning and Indicator Lights

All of the warning and indicator lights are housed in lens and bezel assemblies. See [Fig. 2.19](#).

The warning and indicator light module may include:

- A low water warning light, that comes on when the coolant level is too low.
- Green right and left turn signal indicator lights, that flash on and off when the outside turn signals are flashing.
- A high-beam indicator light, that comes on when the headlights are on high beam.
- A red parking brake indicator light, that comes on when the parking brakes are activated and the ignition switch is in the ON position.

On the air brake system, a chime comes on when:

- The ignition key is in the OFF position and the parking brakes are not applied.

- The ignition key is in the ON position, the transmission is in Neutral (N), the service brake pedal is not depressed, and the parking brakes are not applied.
- The ignition key is in the ON position, the vehicle is not in Neutral (N), and the parking brakes are applied.

- A red warning light for the brake system. When conditions cause the brake system warning light to come on, a warning chime also alerts the driver.
- On the air brake system, the low air light/chime activates when the brake system pressure is low. The light/chime will normally come on when you first start the engine, but will go off when the air pressure in the air tanks reaches approximately 65 to 76 psi (448 to 524 kPa). The parking brakes will not disengage until the air pressure has reached 65 psi (448 kPa).

1	2	3	4	5	6	7	8	9	10	11	12
	STOP ENG	CHECK ENG	LOW WATER	ABS		ATC	SEAT BELT	CHECK TRANS	BRAKE	WATER IN FUEL	
PARK	WAIT TO START	ENG PROT			TRANS TEMP			ENG BRAKE	LOW AIR	SHIFT INHIBIT	
24	23	22	21	20	19	18	17	16	15	14	13

08/09/2000 f610447

1. Left-Turn Signal Indicator Light	9. Check Transmission Warning Light	18. Engine Coolant High Temperature Warning Light
2. Stop Engine Warning Light	10. Brake Warning Light	19. Transmission Temperature Warning Light
3. Check Engine Warning Light	11. Water in Fuel Indicator Light	20. Low Fuel Warning Light
4. Low Engine Coolant Warning Light	12. Right-Turn Signal Indicator Light	21. High or Low Voltage Warning Light
5. ABS Warning Light	13. Blank Position	22. Engine Protection Warning Light
6. High-Beam Indicator Light	14. Shift Inhibit Warning Light	23. Wait to Start Warning Light
7. Automatic Traction Control Indicator Light	15. Low Air Warning Light	24. Parking Brake Indicator Light
8. Seat Belt Warning Light	16. Engine Brake Activation Light	
	17. Oil Pressure Warning Light	

Fig. 2.19, System III Message Center, Pre-2007



- A coolant temperature warning light, that comes on when the engine coolant temperature exceeds the engine manufacturer's recommendations. See the *Caterpillar* or the *Cummins Operation and Maintenance Manual*.
- A check transmission warning light that will come on during vehicle operation (not during start-up) if the ECU (electronic control unit) has signalled a diagnostic code. Diagnostic codes indicate malfunctions in transmission operation. If this light stays on continuously during operation, have the transmission serviced as soon as possible.
- A transmission oil temperature warning light, that comes on when the transmission temperature has exceeded the normal operating temperature.
- A high exhaust system temperature (HEST) warning light, which indicates potentially hazardous exhaust temperatures at the outlet of the tail pipe if speed is below 5 mph (8 kph). It does not signify the need for service; it only alerts the vehicle operator of high exhaust temperatures. See the engine operation manual for details.
- A diesel particulate filter (DPF) warning light, which indicates that a regeneration is required. Change to a more challenging duty cycle, such as highway driving, to raise exhaust temperatures for at least 20 minutes, or perform a stationary regeneration. See the engine operation manual for details.
- A malfunction indicator lamp (MIL), indicates an engine emissions related fault, including, but not limited to the after-treatment system. The MIL lamp applies to the Mercedes-Benz engine only. See the engine operation manual for details.
- An oil pressure warning light, that comes on when the oil pressure falls below the minimum oil pressure recommended by the engine manufacturer. See the *Caterpillar* or the *Cummins Operation and Maintenance Manual* for minimum oil pressure levels.

When the ignition switch is in the ON position, oil- and brake-system warnings (as equipped) activate until the engine starts and minimum pressures are exceeded. If the low-oil pressure warning light or brake system warning light re-

mains on after running the engine for 15 seconds, shut down the engine and determine the cause.

- A low fuel indicator light, that comes on when the vehicle is running low on fuel.

The warning and indicator light module may also include the following lights: wait to start, check engine, water in fuel, stop engine, engine protection, and engine brake. See the *Caterpillar* or the *Cummins Operation and Maintenance Manual* for more information.

**IMPORTANT:** If the warning system does not activate when the ignition switch is in the ON position, repair the system to provide warning protection for oil pressure, coolant temperature, and the brake system.

## Antilock Braking System (ABS)

Vehicles equipped with an antilock braking system (ABS) have an ABS warning light that comes on when the vehicle is started. When the vehicle speed exceeds 6 mph (10 km/h), the light will go off if the ABS system is functioning normally.

### **WARNING**

**If the ABS warning light does not work as described above or comes on while driving, repair the ABS system immediately to ensure full antilock braking capability. Operating the vehicle when the ABS needs to be serviced could cause an accident, possibly resulting in personal injury or death, or property damage.**

See [Chapter 6](#) for more information.

## Instruments

### Speedometer

The speedometer registers vehicle speed in miles per hour (mph). See [Fig. 2.20](#). Standard speedometer gauges are equipped with an odometer that records total distance traveled.

**NOTE:** The tripmeter will indicate total trip miles. Selecting trip reset will erase the current display and start counting at 00000.0 miles.

# Driver Controls and Instruments

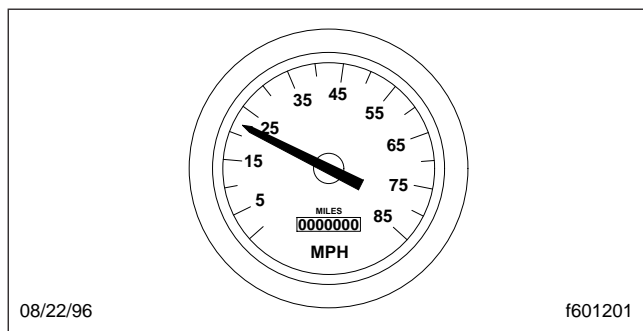

**Fig. 2.20, Speedometer**

## Coolant Temperature Gauge

During normal engine operation, the coolant temperature gauge should read in the normal range. See [Fig. 2.21](#) or [Fig. 2.22](#). If the temperature remains below or exceeds the normal range, inspect the cooling system to determine the cause.

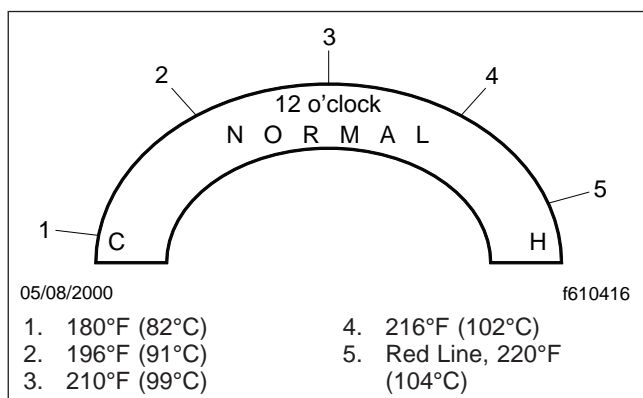

**Fig. 2.21, Engine Temperature (vehicles built before March 1, 2000)**

## Engine Oil Pressure Gauge

The oil pressure gauge should read in the normal range. See [Fig. 2.23](#) and [Table 2.1](#).



**CAUTION**

**A sudden decrease or absence of engine oil pressure may indicate mechanical failure. Bring the vehicle to a safe stop and investigate the cause to prevent further damage. Do not operate the engine until the cause has been determined and corrected.**

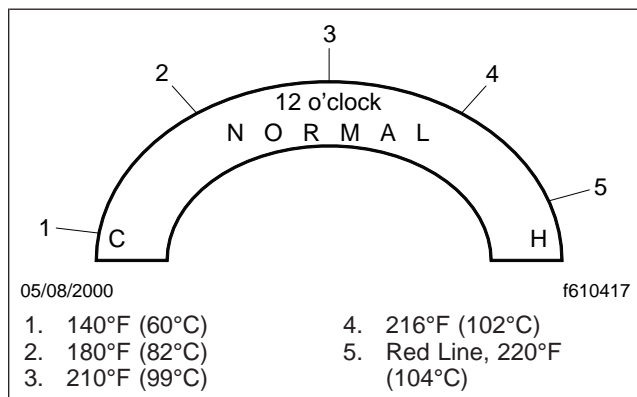

**Fig. 2.22, Engine Temperature (vehicles built since March 1, 2000)**

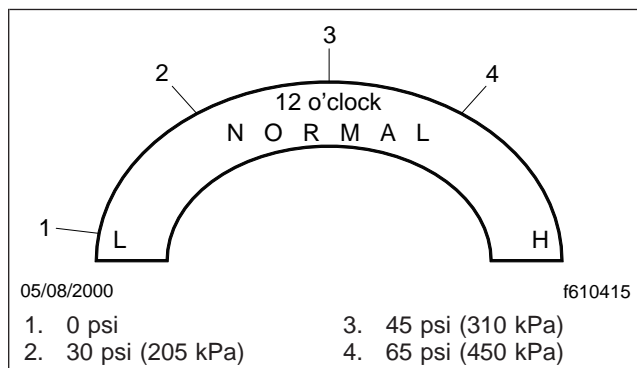

**Fig. 2.23, Oil Pressure**

Oil Pressure*		
Engine Model	Oil Pressure at Idle Speed psi (kPa)	Oil Pressure at Rated RPM psi (kPa)
Caterpillar	6–10 (41–69)	48–52 (331–359)
Cummins	10–15 (69–103)	45–55 (310–379)

\* Oil pressures are given with the engine at operating temperatures. With the engine cold, oil pressures may be higher.

**Table 2.1, Oil Pressure**

## Voltmeter

The voltmeter indicates the vehicle charging system voltage when the engine is running, and the battery voltage when the engine is stopped. See [Fig. 2.24](#). By monitoring the voltmeter, the driver can be aware of potential charging system problems and have them repaired before the batteries discharge enough to create starting difficulties.

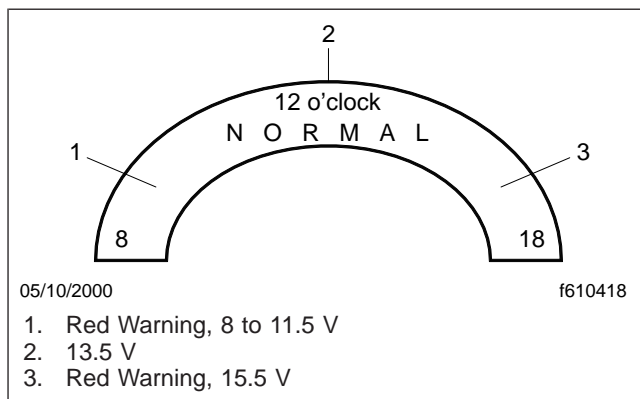

Fig. 2.24, Voltmeter

The voltmeter should indicate voltage in the normal range when the engine is running. The voltage of a fully charged battery is 12.7 to 12.8 volts when the engine is stopped. A completely discharged battery will produce only about 12.0 volts. The voltmeter will indicate lower voltage as the vehicle is being started or when electrical devices in the vehicle are being used.

If the voltmeter shows an undercharged or overcharged condition for an extended period, have the charging system and batteries checked at a repair facility.

NOTE: Some vehicles may be equipped with a battery isolator system and a gel cell battery by the body builder. On these vehicles, the voltmeter measures the average voltage of all of the batteries when the engine is running. When the engine is stopped, the voltmeter shows only the engine-starting battery voltage and does not indicate the voltage of the gel cell batteries.

## CAUTION

**Gel cell batteries can be damaged if the battery voltage is allowed to drop below 12.0 volts or if the charging voltage is more than 14.1 volts. Start the engine to recharge the gel cell before the battery becomes fully discharged. If an external charger is needed, disconnect the gel cell battery and use only an external battery charger that has been approved for gel cell batteries.**

## Fuel Gauge

The fuel gauge indicates the amount of fuel in the fuel tank(s). See Fig. 2.25.

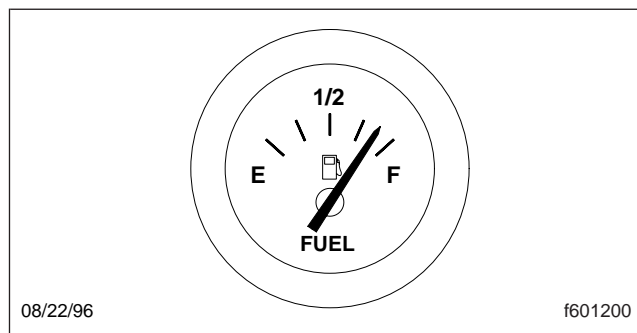

Fig. 2.25, Fuel Gauge

## Tachometer

The tachometer indicates the revolutions per minute (rpm) of the engine. See Fig. 2.26.

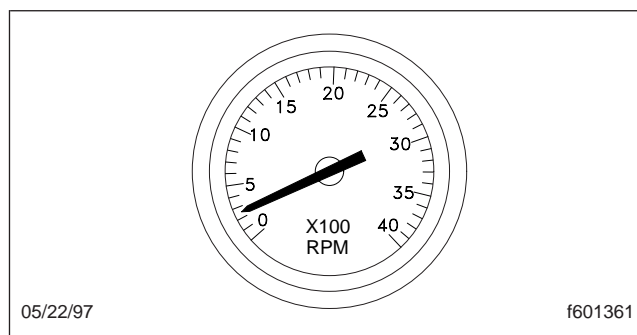

Fig. 2.26, Tachometer

## Transmission Temperature Gauge (optional)

The transmission temperature gauge indicates the temperature of the transmission oil. See Fig. 2.27. The temperature gauge reading should not exceed 225°F (107°C).

## CAUTION

**If the transmission continues to overheat during normal operation, have it checked and repaired. Continued operation over 300°F (149°C) may cause damage to the transmission.**

# Driver Controls and Instruments

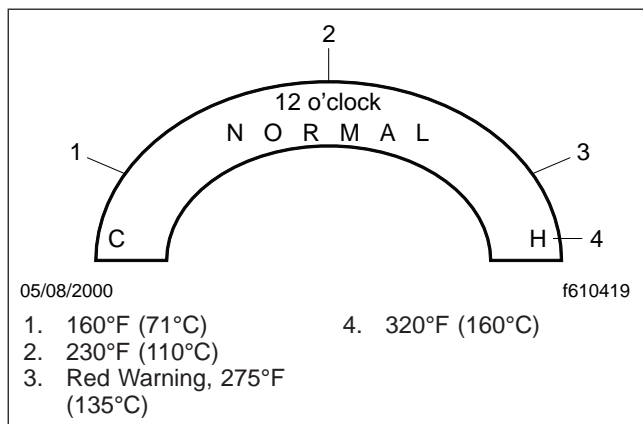

Fig. 2.27, Transmission Temperature

## Air Pressure Gauges

**IMPORTANT:** Two separate air pressure gauges indicate air pressure in the front axle and the rear axle air brake systems. See Fig. 2.28. Build air pressure in both systems to 95 to 120 psi (620 to 827 kPa) before moving. An alarm will sound if the pressure drops below a safe operating range.

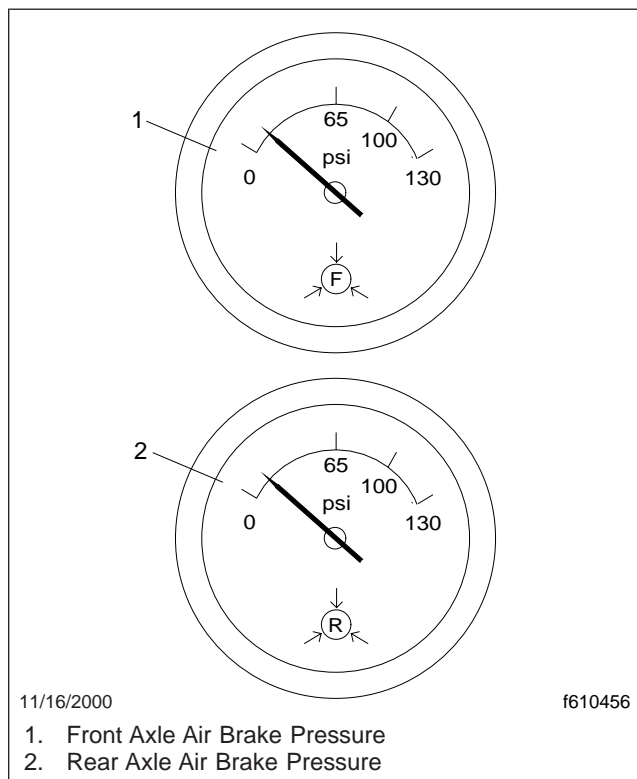

Fig. 2.28, Air Pressure Gauges

## Intake-Air Restriction Indicator

An intake-air restriction indicator measures the vacuum on the engine side of the air cleaner at the air cleaner outlet. See Fig. 2.29. Replace the air cleaner element every two years, or when filter restriction reaches 25 inH<sub>2</sub>O. Reset the indicator by pressing the button on the bottom.

**NOTE:** A new air cleaner element will normally read 10 to 12 inH<sub>2</sub>O. Rain or snow can wet the filter and cause a higher than normal reading temporarily.

See Table 2.2 for the intake-air restriction level.

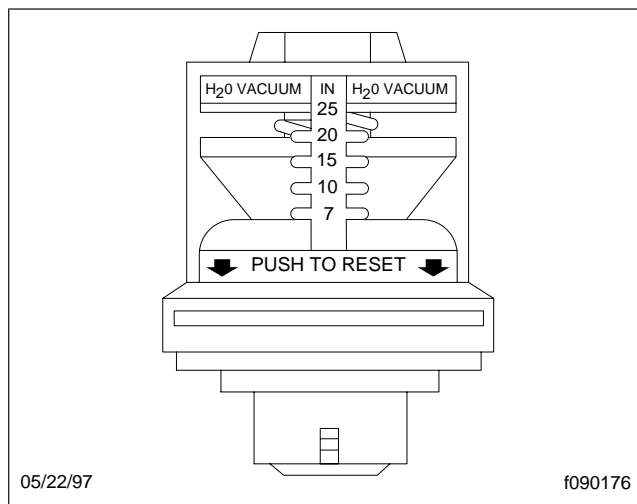

Fig. 2.29, Intake-Air Restriction Indicator

Intake Air Restriction	
Engine*	Maximum Restriction with a Dirty Air Filter
Caterpillar C7	25 inH <sub>2</sub> O
Cummins ISB, ISC, and ISL	25 inH <sub>2</sub> O

\* Turbocharged engines must be checked at full load and governed engine speed.

Table 2.2, Intake Air Restriction

## Light Bar Control Unit (LBCU)

The light bar control unit (LBCU) instrument cluster is a full-featured, individual-gauge cluster with an intelligent light bar (ILB). The individual gauges have light emitting diode (LED) backlighting. The light bar control unit receives inputs for the gauges. Various gauge configurations are available.

## Warning and Indicator Lights

**IMPORTANT:** The LBCU is capable of determining when input information is lost. The loss of input data will be noticeable to the operator by movement of the gauge to zero. The odometer value will not be driven to zero if total loss of vehicle distance data occurs. When data input is lost, hyphens (-) will replace the digits in the data field on the display screen.

The ILB contains the following warning and indicator lights. See [Fig. 2.30](#) and [Fig. 2.31](#):

- Green right and left turn signal indicator lights that flash on and off when the outside turn signals are flashing.
- A yellow check transmission indicator light that comes on during vehicle operation if the transmission electronic control unit (ECU) signals a diagnostic fault code. Diagnostic codes indicate malfunctions in the transmission operation. If the light stays on continuously during operation, have the transmission serviced as soon as possible.
- A blue high-beam indicator light that comes on when the headlights are on high beam.
- A red low air warning light normally comes on when the air pressure in the air tanks falls below 65 psi (448 kPa). The light will normally come on when the engine is first started, but goes off when the air pressure in the air tanks reaches approximately 65 to 76 psi (448 to 524 kPa).
- A red parking brake warning light that comes on when the parking brake is activated and the ignition switch is in the ON position.
- A yellow wait-to-start indicator light that comes on when the intake heater is active.

- A green engine brake indicator that comes on when the engine brake is applied. Wait until the indicator light goes off to start the engine.
- A green cruise-on indicator light that comes on when the cruise control is on.
- A yellow shift-inhibit indicator light that comes on when the transmission ECU is prohibiting shifting.
- A yellow antilock braking system (ABS) indicator light that comes on when the vehicle is started. If an ABS fault has been cleared, the vehicle speed must exceed 7 mph (10 km/h), for the light to go off if the ABS system is functioning normally.

## WARNING

**If the ABS warning light does not work as described above or comes on while driving, repair the ABS system immediately to ensure full antilock braking capability. Operating the vehicle when the ABS needs to be serviced could cause an accident, possibly resulting in personal injury or death, or property damage.**

The ILB may also include the following lights: check engine, stop engine, and engine protection. See the **Caterpillar**, the **Cummins**, or the **Mercedes-Benz Operation and Maintenance Manual** for more information.

**IMPORTANT:** If the warning system does not activate when the ignition switch is in the ON position, repair the system to provide proper warning protection.

**NOTE:** When the ignition is turned on, all of the indicator lights will illuminate for approximately three seconds to allow the operator to perform a bulb check.

## Gauges

The light bar control unit has the following gauges: A three-in-one gauge which includes the tachometer, fuel gauge, and voltmeter; the speedometer; and a four-in-one gauge which includes the oil pressure, coolant temperature, and the primary and secondary air gauges. See [Fig. 2.32](#) and [Fig. 2.33](#) for an example of a typical instrument panel. The following is a description of the instrument panel gauges.

# Driver Controls and Instruments

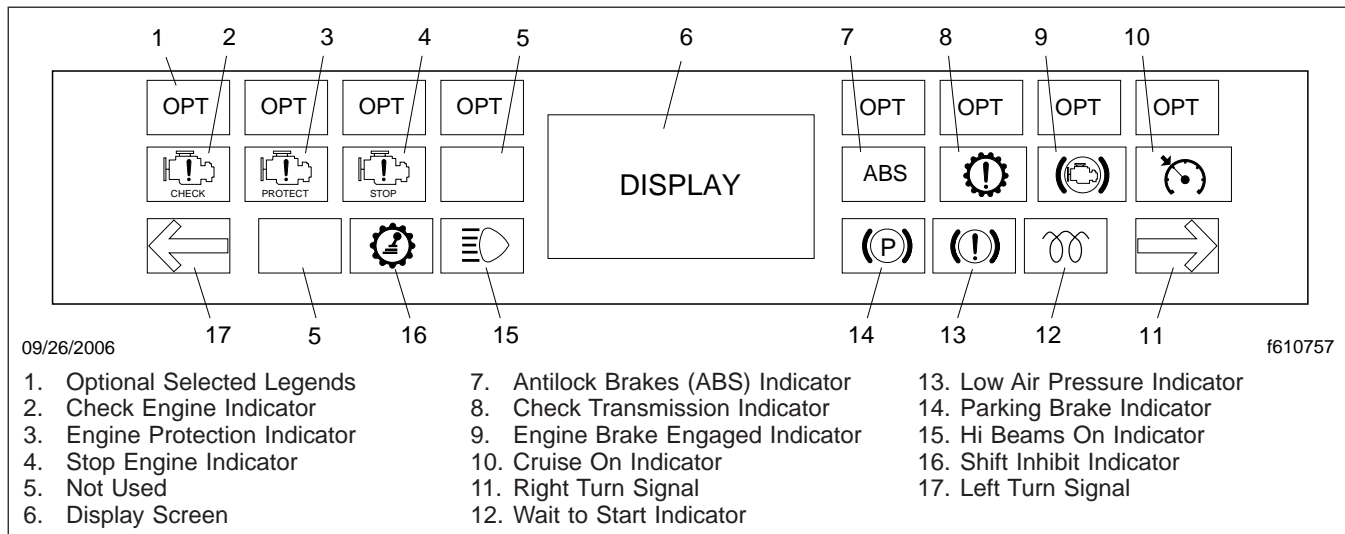

Fig. 2.30, Light Bar Control Unit (LBCU) Message Center, Pre-2007

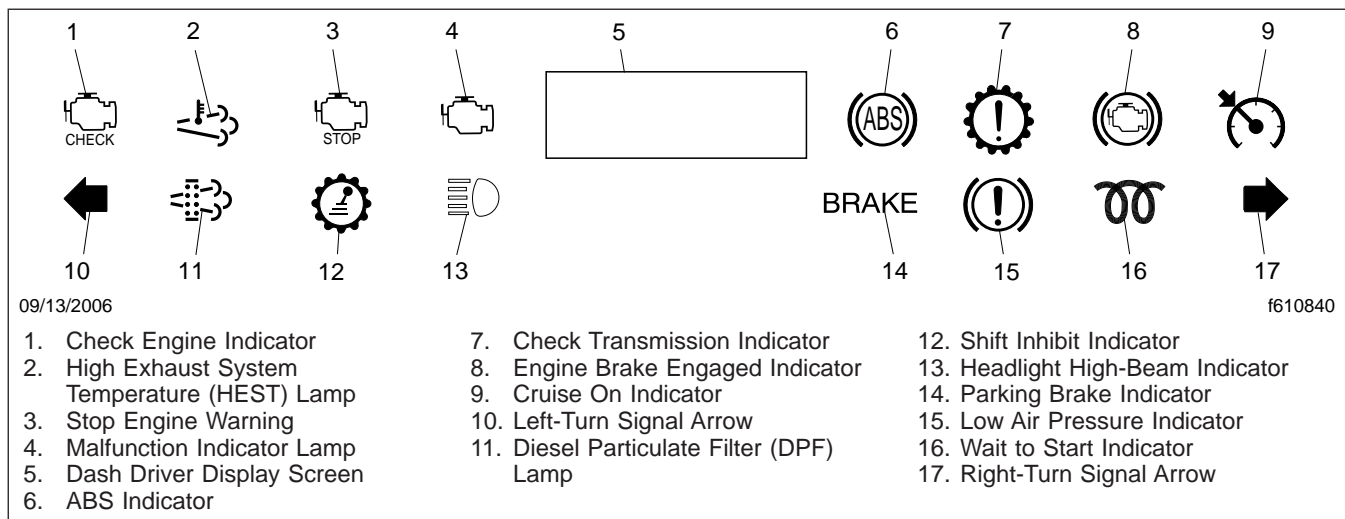

Fig. 2.31, LBCU Message Center, EPA07 Compliant

## Speedometer

The speedometer indicates vehicle speed in miles per hour (mph) or kilometers per hour (km/h). See [Fig. 2.34](#).

## Tachometer

The tachometer indicates the revolutions per minute (rpm) of the engine. See [Fig. 2.35](#).

## Fuel Gauge

The fuel gauge indicates the amount of fuel in the fuel tank. See [Fig. 2.35](#).

## Turbo Boost Gauge (optional)

The turbo boost gauge indicates the boost pressure at the turbocharger from 0 to 50 psi (0 to 345 kPa). See the **Caterpillar**, the **Cummins**, or the **Mercedes-Benz Operation and Maintenance Manual** for more information.



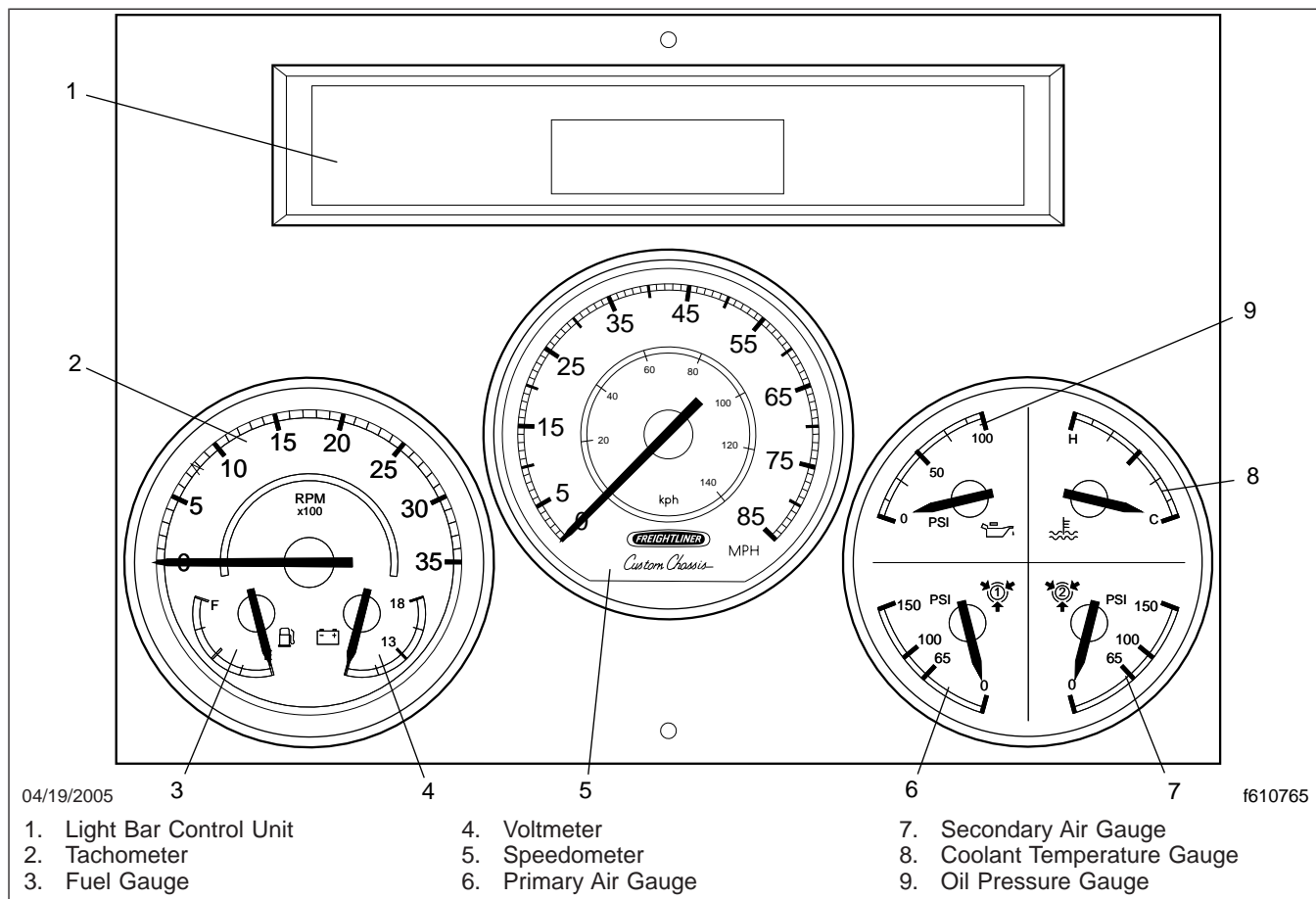

Fig. 2.32, Typical Instrument Panel, Pre-2007

## Coolant Temperature Gauge

During normal engine operation, the coolant temperature gauge should read in the normal range between cold and hot. If the temperature remains below or exceeds the normal range, inspect the cooling system to determine the cause. See [Fig. 2.36](#).

## Engine Oil Pressure Gauge

The oil pressure gauge should read in the normal range, from 2 to 80 psi (14 to 552 kPa). See [Fig. 2.36](#).



**A sudden decrease or absence of engine oil pressure may indicate mechanical failure. Bring the vehicle to a safe stop and investigate the**

**cause to prevent further damage. Do not operate the engine until the cause has been determined and corrected.**

## Voltmeter

The voltmeter indicates the vehicle charging system voltage when the engine is running, and battery voltage when the engine is stopped. By monitoring the voltmeter, the driver can be aware of potential charging system problems and have them repaired before the batteries discharge enough to create starting difficulties.

The voltmeter shows the voltage of the battery when the engine is running. The voltage of a fully charged battery is 12.7 to 12.8 volts when the engine is

# Driver Controls and Instruments

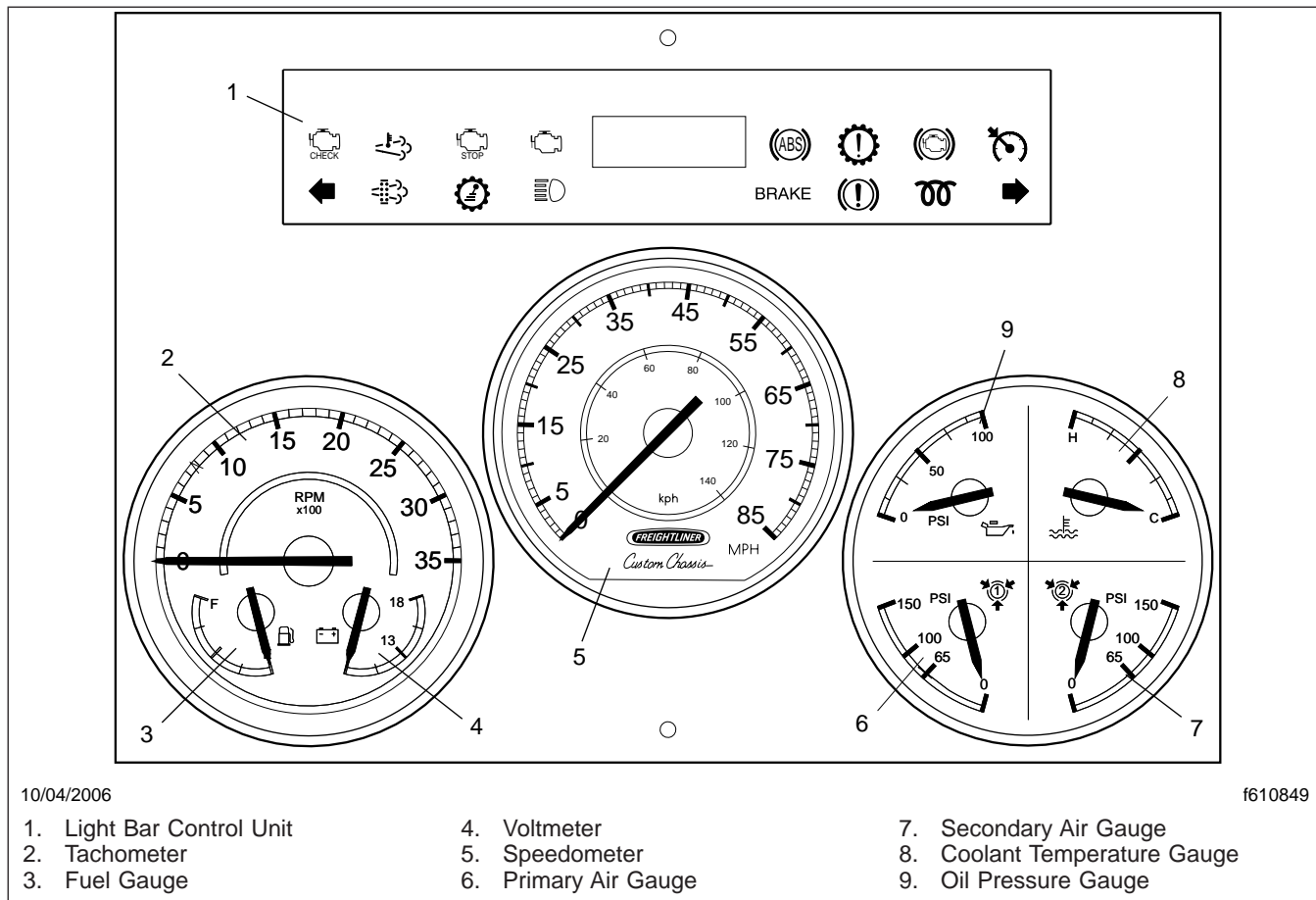

**Fig. 2.33, Typical Instrument Panel, EPA07 Compliant**

stopped. A completely discharged battery will produce only about 12.0 volts. The voltmeter will indicate lower voltage as the vehicle is being started or when electrical devices in the vehicle are being used.

If the voltmeter shows an undercharged or overcharged condition for an extended period, have the charging system and batteries checked at a repair facility.

**NOTE:** Some vehicles may be equipped (by the body builder) with a battery isolator system and a gel cell battery. On these vehicles, the voltmeter measures the average voltage of all the batteries when the engine is running. When the engine is stopped, the voltmeter shows the voltage of the engine-starting batteries.

## Air Pressure Gauges

**IMPORTANT:** Two separate air pressure gauges indicate air pressure in the primary and secondary air systems. Build air pressure in both systems to 95 to 120 psi (620 to 827 kPa) before moving. It is normal to observe fluctuation in these gauges during operation of the vehicle. An alarm will sound if the pressure drops below a safe operating range.

## Transmission Temperature Gauge (optional)

The transmission temperature gauge indicates the temperature of the transmission oil.



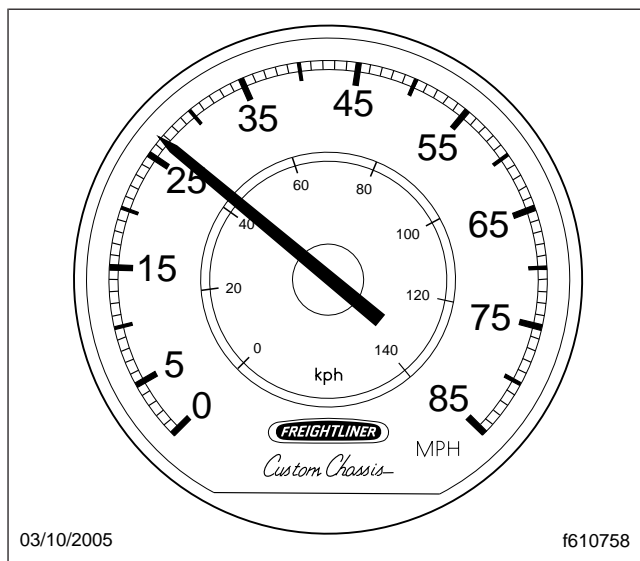

Fig. 2.34, Speedometer

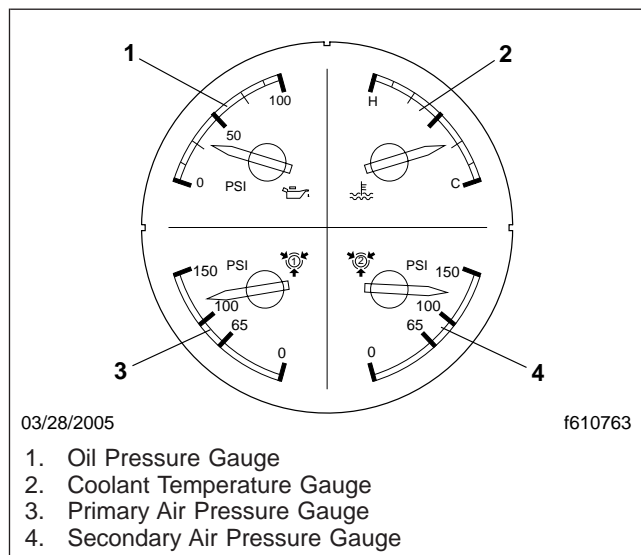

Fig. 2.36, Pressure/Temperature Gauges

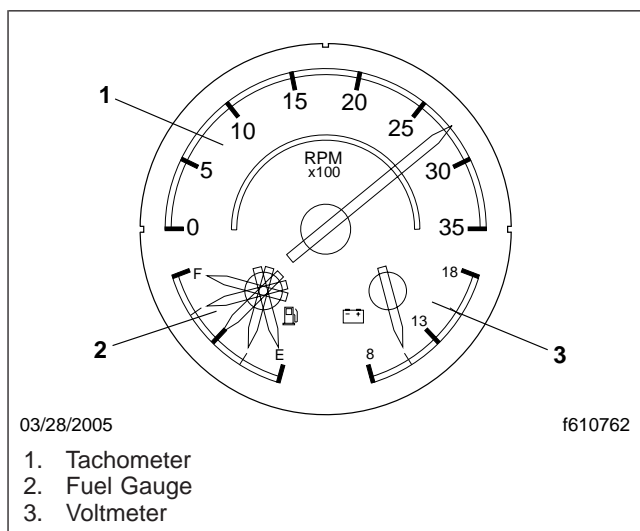

Fig. 2.35, Three-In-One Gauge

## CAUTION

If the transmission continues to overheat during normal operation, have it checked and repaired. Continued operation may cause damage to the transmission.

## Audible Alarms

During start-up, the LBCU will perform a self-test and an audible alarm will sound until the self-test is completed. If any faults are found during the self-test, ERROR will appear on the display screen. Acknowledge any alarms before proceeding to the pretrip checklist. The alarm will also sound if any of the following conditions occur:

- Air pressure falls below 65 psi (448 kPa).
- Anytime the low air warning light is activated. On the air system, the low air light/audible alarm will normally come on when the engine is first started, but will go off when the air pressure in the air tanks reaches approximately 65 to 76 psi (448 to 524 kPa). The parking brake will not disengage until the air pressure has reached 65 psi (448 kPa).
- Emergency engine shutdown is activated.
- The parking brake is applied and the transmission is not in neutral.
- The transmission is in neutral or the ignition is off, and the parking brake is not set and the service brake is not depressed.
- The turn indicator is active.
- Anytime the ignition is turned off when the panel lamps are still illuminated.

# Driver Controls and Instruments

## Emergency Shutdown

The LBCU will shut down if the voltage supply is not within the normal operating range of 9 to 16 volts for more than 10 milliseconds (msec). During emergency shutdown, the gauge pointers will freeze, the display will go blank, and the lamps will turn off. When the power is restored to within the normal operating range following an emergency shutdown, the needles will resynchronize to zero, and the self-test will be performed before resuming normal operation.

## Information Center

The LBCU is an interactive graphical display that is capable of displaying text messages and graphics to communicate real-time information about the status and performance of the vehicle to the operator. This information is organized in a menu-structured format.

## Power Initialization

When the ignition is turned on, the information center will illuminate with the Freightliner Custom Chassis logo. If there are no alarms detected from the self-test, the driver checklist is displayed.

## Navigating the Menu Screen

Navigate the menu structure using the toggle switch, located in the driver's area. The "up" arrow of the toggle switch is yellow. See [Fig. 2.37](#).

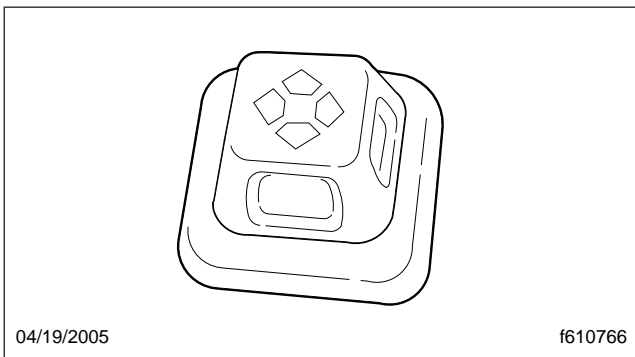

**Fig. 2.37, Toggle Switch**

## Menu Structure

The menu structure is organized around three menu screens: the ignition off screen, the home screen, and the setup/maintenance/diagnostics screen. Each of these screens contains lists of the sub-menu screens that may be accessed by highlighting the

desired sub-menu and clicking the right arrow on the toggle switch.

## Ignition Off Screen

When the ignition is OFF and the headlights are ON, the odometer is displayed. When the ignition is OFF and the generator is ON, the generator hours are displayed (if connected by the body builder).

## Home Screen

**NOTE:** Alarm messages have priority over other display screens. If no alarms are present or all alarms have been acknowledged, the driver checklist will be displayed.

The following options are found in the menu and sub-menus of the home screen.

- A pretrip inspection checklist that includes 19 items and 10 driver-entered options. Once each item has been reviewed, click the right arrow of the toggle switch to place a check by the item. Click the left arrow to exit the checklist.
- Driver's Favorite Categories—There are nine categories that the driver can select from; three can be viewed at one time. Select the category desired by using the up/down toggle switch. Then, click the right arrow of the toggle switch for three seconds to access the sub-menus within each category. Finally, click the left arrow of the toggle switch to exit.
- Setup/Maintenance/Diagnostics screen is actually three different categories for the driver to use. They are as follows:
  1. Setup—Includes set time and date, configure checklist, select metric/english, set LCD properties.
  2. Maintenance—Includes engine oil, engine air filter, engine fuel filter, transmission oil, generator oil, generator fuel filter, generator use time.
  3. Diagnostics—Includes check gauges, check icons, check inputs, check outputs, engine diagnostics, ABS diagnostics, hardware/software version, and software debug display (this menu is used by the gauge manufacturer only).

The following steps are used to make changes within the various categories.

1. From the Driver's Favorite Category menu, hold down the right arrow of the toggle switch for five seconds to select the setup/maintenance/diagnostics screen.
2. Press the down arrow on the toggle switch to select either setup, maintenance, or diagnostics.
3. Press the right arrow on the toggle switch to select the sub-category; "Set Time and Date" for example.
4. Use the left/right arrows on the toggle switch to change the information, and the up/down arrows to move within the sub-category.
5. Once all changes have been made, hold down the right arrow on the toggle switch.

## Menu Structure

The menu structure road map is provided to illustrate the screens that are available in the information center and the path to specific screens. Refer to the road maps to set the time and date, view engine diagnostics, etc. See [Fig. 2.38](#), [Fig. 2.39](#), [Fig. 2.40](#), [Fig. 2.41](#), [Fig. 2.42](#), [Fig. 2.43](#), [Fig. 2.44](#), [Fig. 2.45](#), [Fig. 2.46](#), [Fig. 2.47](#), [Fig. 2.48](#), [Fig. 2.49](#), [Fig. 2.50](#), [Fig. 2.51](#), [Fig. 2.52](#), [Fig. 2.53](#), [Fig. 2.54](#), [Fig. 2.55](#), [Fig. 2.56](#), [Fig. 2.57](#), and [Fig. 2.58](#).

## Multiple Module Data Computer (MMDC)

The Multiple Module Data Computer (MMDC) reads and shares vehicle information from the engine, transmission, and brake system computers. Information is taken from a data bus and sensor signals (analog, digital, or frequency) on the vehicle. It is then converted to digital information for the gauges to read.

The instrument system consists of three major components:

- An annunciator module that concentrates all of the warning and indicator lights in one area to facilitate efficient visual scanning of the panel.
- An assortment of individual analog style gauges that display the value of specific performance parameters.
- An interactive graphical information center display that is capable of communicating more

detailed information about the status and performance of the vehicle as needed.

The location of these components in the dash may vary from one vehicle to another.

## Annunciator Module

The annunciator module contains the following warning and indicator lights. See [Fig. 2.59](#).

- Green right and left turn signal indicator lights, that flash on and off when the outside turn signals are flashing.
- A check transmission warning light that will come on during vehicle operation if the transmission electronic control unit (ECU) has signalled a diagnostic fault code. Diagnostic codes indicate malfunctions in the transmission operation. If this light stays on continuously during operation, have the transmission serviced as soon as possible.
- A blue high-beam indicator light that comes on when the headlights are on high beam.
- On the air brake system, the low air light activates when the brake system pressure is low. The light will normally come on when the engine is first started, but will go off when the air pressure in the air tanks reach approximately 65 to 76 psi (448 to 524 kPa).
- A red parking brake indicator light that comes on when the parking brake is activated and the ignition switch is in the ON position.
- An amber wait to start indicator light that comes on when the intake-air pre-heater is activated.
- An amber check info center indicator light that comes on when the info center is displaying an alarm condition or warning message.
- A cruise on indicator light that comes on when the cruise control is on.
- A shift inhibit warning light that comes on when the transmission ECU is prohibiting shifting.
- Vehicles equipped with an antilock braking system (ABS) have an ABS warning light that comes on when the vehicle is started. If an ABS fault has been cleared, the vehicle speed must exceed 7 mph (10km/h), for the light to

# Driver Controls and Instruments

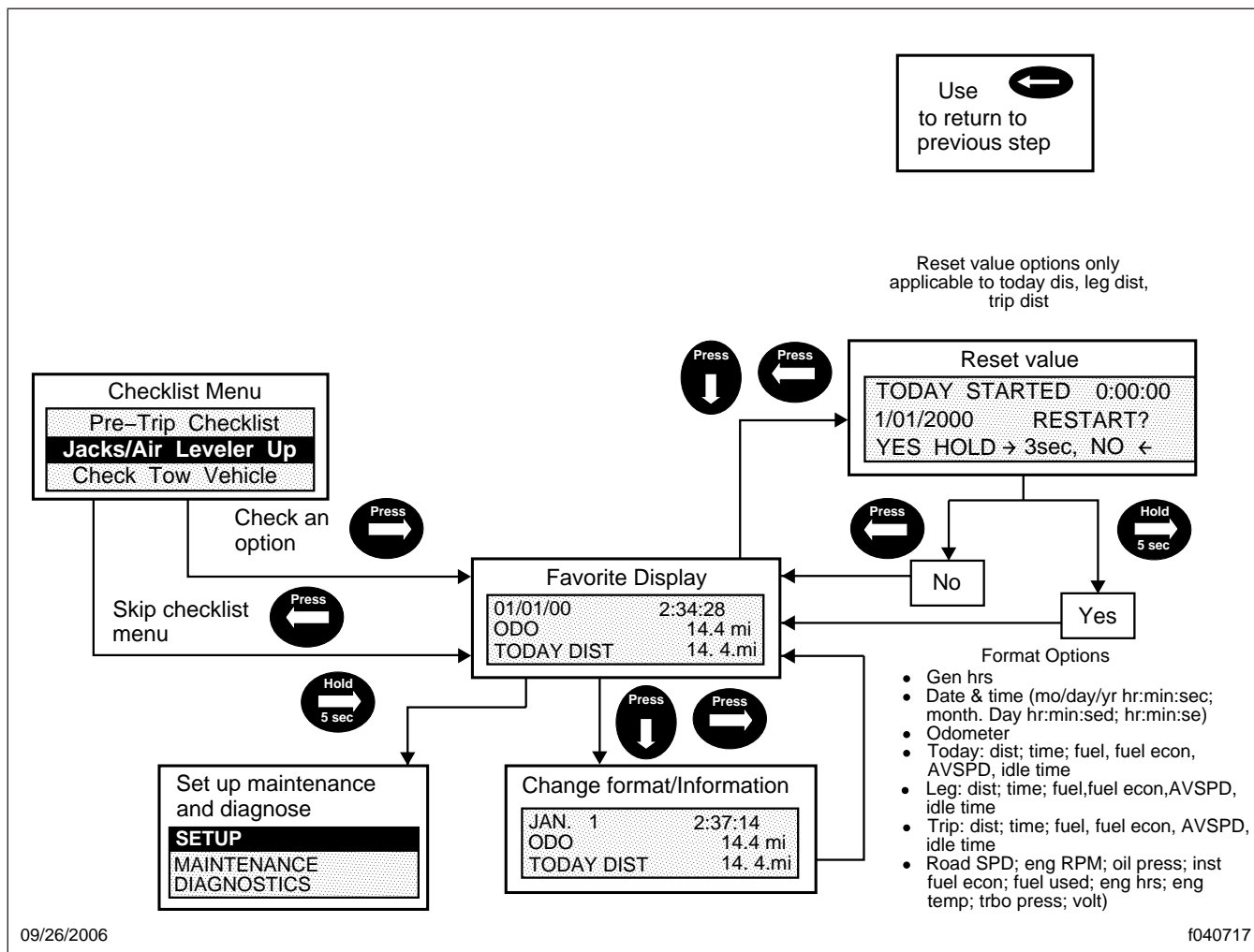

Fig. 2.38, Favorite Display

go off if the ABS system is functioning normally.

## WARNING

If the ABS warning light does not work as described above or comes on while driving, repair the ABS system immediately to ensure full antilock braking capability. Operating the vehicle when the ABS needs to be serviced could cause an accident, possibly resulting in personal injury or death, or property damage.

The annunciator module may also include the following lights: check engine, stop engine, and engine protection. See the *Caterpillar* or the *Cummins Op-*

*eration and Maintenance Manual* for more information.

**IMPORTANT:** If the warning system does not activate when the ignition switch is in the ON position, repair the system to provide proper warning protection.

## Gauges

See [Fig. 2.60](#) for an example of a typical instrument panel. The following is a description of the instrument panel gauges.

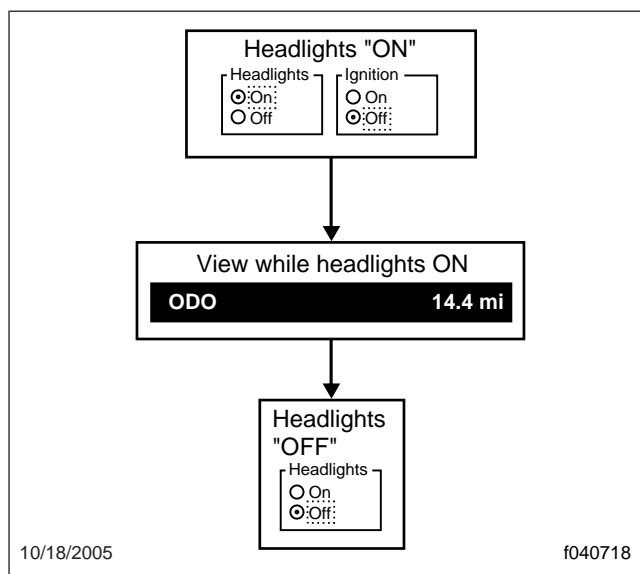

**Fig. 2.39, View Odometer Value**

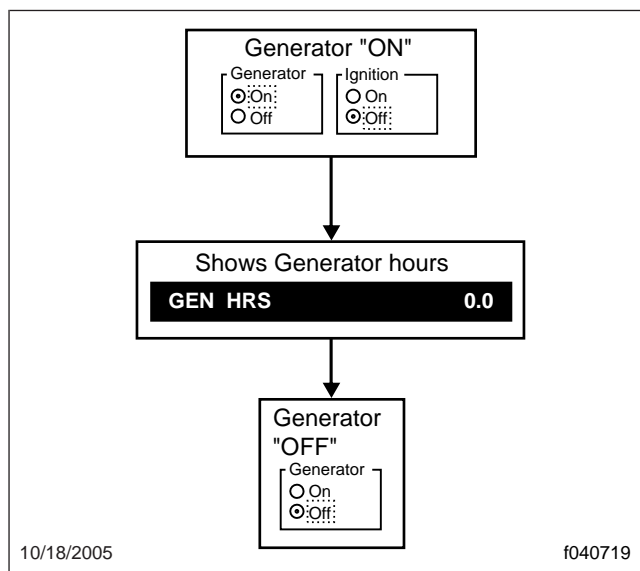

**Fig. 2.40, View Generator Hours**

## Speedometer/Odometer

The speedometer registers vehicle speed in miles per hour or kilometers per hour (mph/kph). Standard speedometers are equipped with a combination odometer/tripmeter that records total distance traveled and trip distance. Resetting the trip odometer will erase the current display and start counting at 0000.0 miles. A short press (less than three seconds)

of the trip reset will toggle the display between trip mode and odometer mode. A long press (greater than three seconds) of the trip reset while in trip mode will reset the tripmeter. The tripmeter can also be reset using the information center. The odometer will be displayed with six numbers and no decimal (000000), while the tripmeter will be displayed with four numbers and one decimal (0000.0).

## Tachometer

The tachometer indicates the revolutions per minute (rpm) of the engine.

## Coolant Temperature Gauge

During normal engine operation, the coolant temperature gauge should read in the normal range. If the temperature remains below or exceeds the normal range, inspect the cooling system to determine the cause.

## Fuel Gauge

The fuel gauge indicates the amount of fuel in the fuel tank.

## Turbo Boost Gauge (optional)

The turbo boost gauge indicates the boost pressure at the turbo. See the *Caterpillar* or the *Cummins Operation and Maintenance Manual* for more information.

## Engine Oil Pressure Gauge

The oil pressure gauges should read in the normal range.



**A sudden decrease or absence of engine oil pressure may indicate mechanical failure. Bring the vehicle to a safe stop and investigate the cause to prevent further damage. Do not operate the engine until the cause has been determined and corrected.**

## Voltmeter

The voltmeter indicates the vehicle charging system voltage when the engine is running, and battery voltage when the engine is stopped. By monitoring the voltmeter, the driver can be aware of potential charging system problems and have them repaired before

# Driver Controls and Instruments

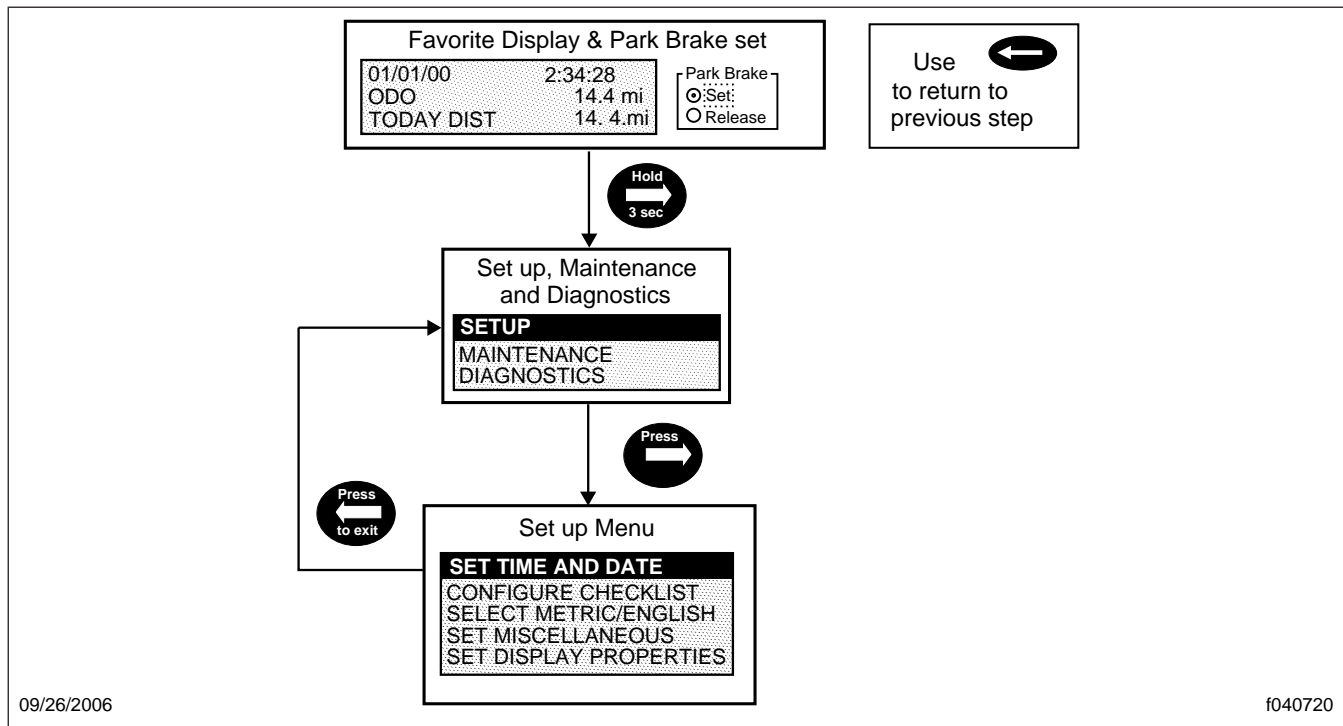

Fig. 2.41, Set Up Menu

the batteries discharge enough to create starting difficulties.

The voltmeter should indicate voltage in the normal range when the engine is running. The voltage of a fully charged battery is 12.7 to 12.8 volts when the engine is stopped. A completely discharged battery will produce only about 12.0 volts. The voltmeter will indicate lower voltage as the vehicle is being started or when electrical devices in the vehicle are being used.

If the voltmeter shows an undercharged or overcharged condition for an extended period, have the charging system and batteries checked at a repair facility.

Some vehicles may be equipped (by the body builder) with a battery isolator system and a gel cell battery. On these vehicles, the voltmeter measures the average voltage of all the batteries when the engine is running. When the engine is stopped, the voltmeter shows only the gel cell battery voltage and does not indicate the voltage of the engine-starting batteries.

## Air Pressure Gauges

**IMPORTANT:** Two separate air pressure gauges indicate air pressure in the primary and secondary air systems. Build up air pressure in both systems to 95 to 120 psi (620 to 827 kPa) before moving. It is normal to observe fluctuation in these gauges during operation of the vehicle. An alarm will sound if the pressure drops below a safe operating range.

## Transmission Temperature Gauge (optional)

The transmission temperature gauge indicates the temperature of the transmission oil.

### CAUTION

**If the transmission continues to overheat during normal operation, have it checked and repaired. Continued operation may cause damage to the transmission.**



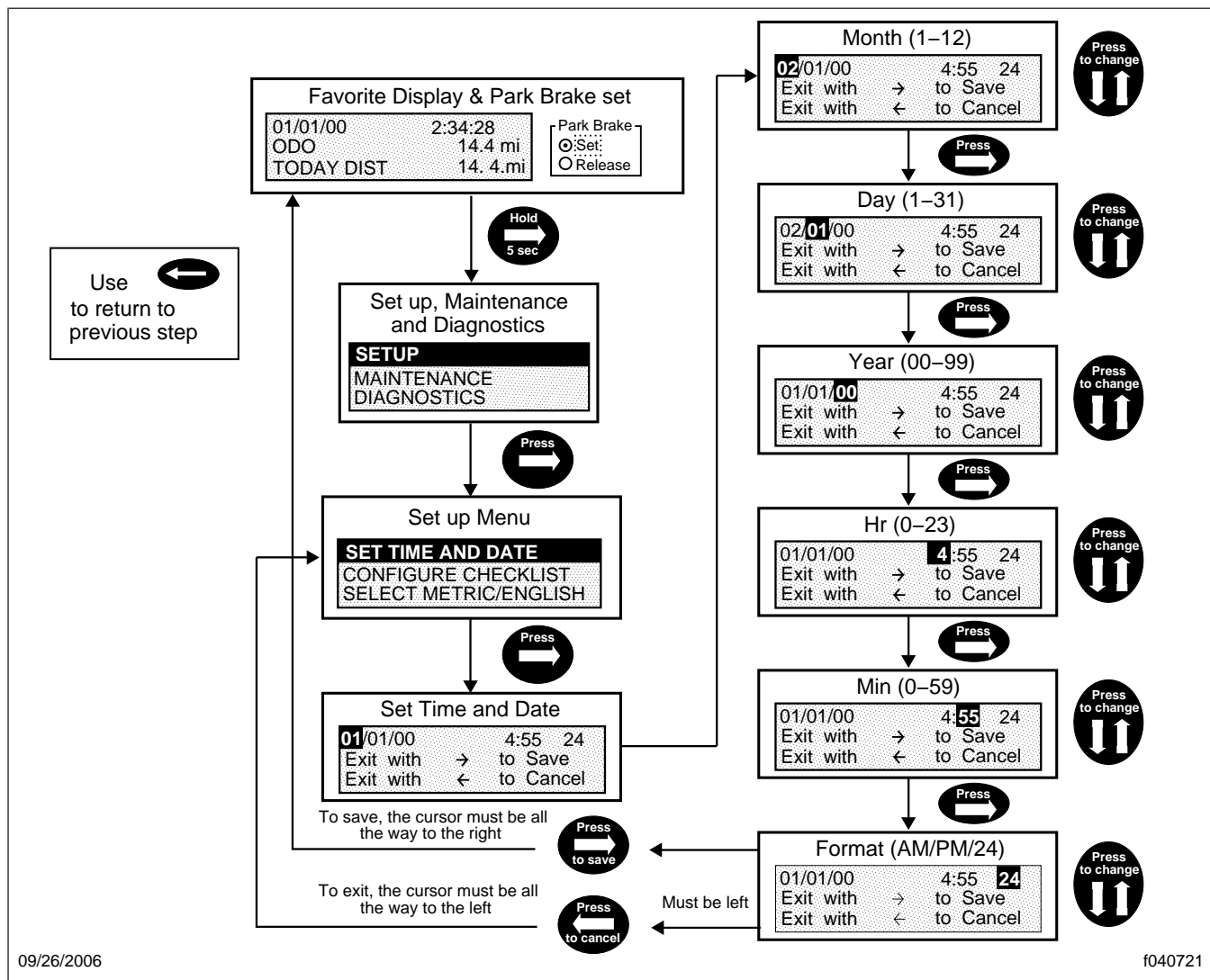

Fig. 2.42, Set Time and Date

## Audible Alarms

The instrumentation system provides for the following audible alarms:

- A rapidly pulsating buzzer sounds anytime the stop engine warning light is activated.
- A rapidly pulsating buzzer sounds anytime the low air warning light is activated. On the air system, the low air light/buzzer will normally come on when the engine is first started, but will go off when the air pressure in the air tanks reaches approximately 65 to 76 psi (448 to 524 kPa). The parking brake will not disengage until the air pressure has reached 65 psi (448 kPa).
- A chirping buzzer sounds under the following conditions:
  - The ignition key is in the ON position, the transmission is not in neutral (N), and the parking brake is applied.
  - The ignition key is in the ON position, the transmission is in neutral (N), the





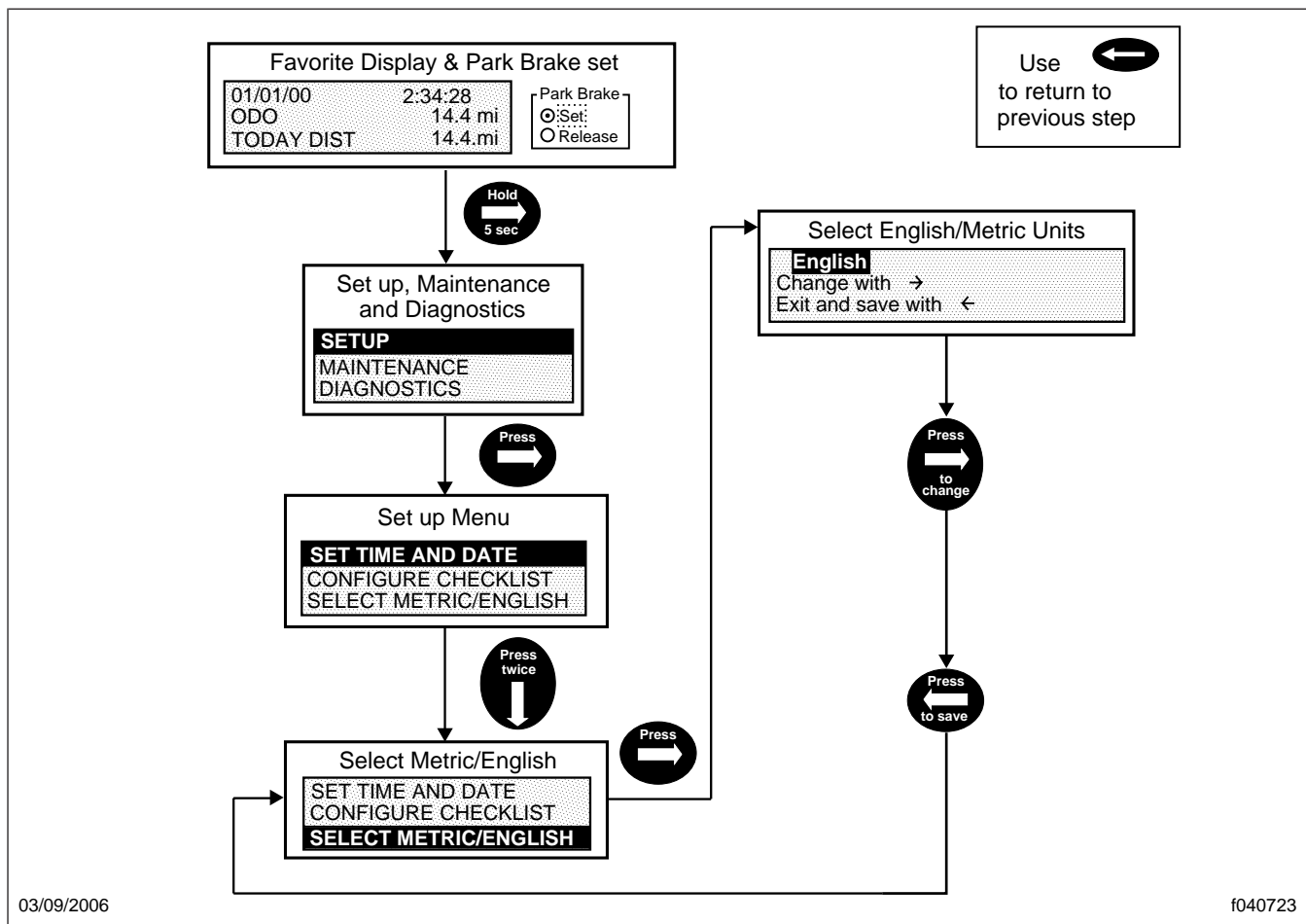

Fig. 2.44, Change Units

## Navigating the Menu Screens

The menu structure is navigated using six buttons located on the face of the information center. See [Fig. 2.61](#) for the symbol, name, and function of the navigation buttons.

## Menu Structure

The menu structure is organized around three menu screens: the home screen, the setup screen, and the alarm screen. Each of these screens contains lists of the sub-menu screens that may be accessed by highlighting the desired sub-menu and pushing the enter button.

## Home Screen Features

The following real time trip computer data is found in the trip computer and trip meter sub-menus of the home screen.

- Instantaneous Fuel Economy
- Average Fuel Economy
- Fuel Remaining
- Odometer
- Multiple Trip Odometers

The following vehicle performance data is found in the engine sub-menu of the home screen.

- (E-information) A screen that simultaneously displays speed, RPM, and gear information.



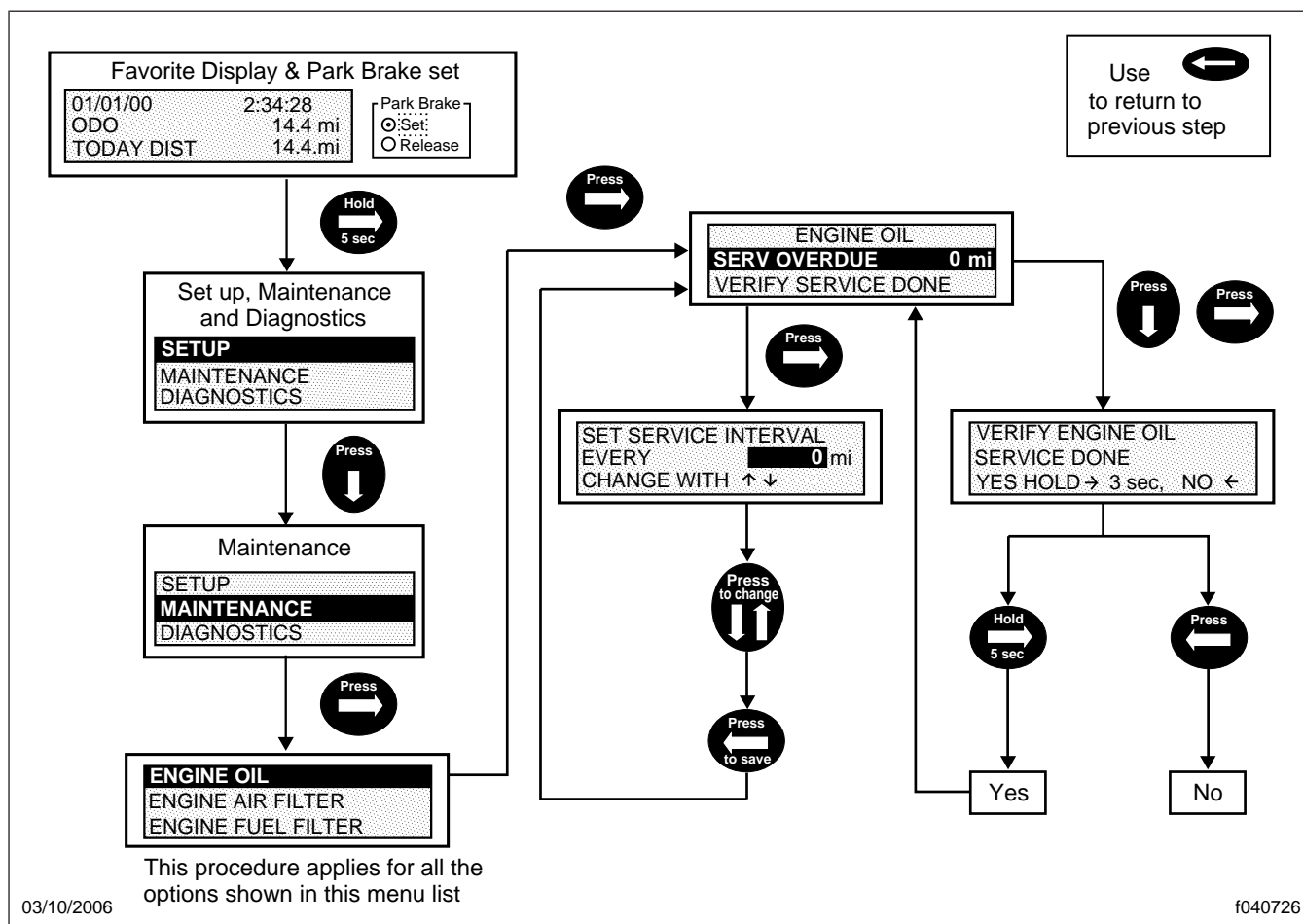

Fig. 2.46, Maintenance Menu

## Menu Structure Road Map

The menu structure road map is provided to illustrate the screens that are available in the information center, the path to specific screens, and the details of each individual screen. See [Fig. 2.62](#), [Fig. 2.63](#), [Fig. 2.64](#), [Fig. 2.65](#), [Fig. 2.66](#), and [Fig. 2.67](#).

## Instrumentation Control Unit (front-engine oil diesel chassis)

[Figure 2.68](#) shows a typical set of instruments for vehicles equipped with the MC Recreational Vehicle instrument cluster (ICU3-M2).

[Figure 2.69](#) and [Figure 2.70](#) shows a more basic instrument cluster. The tachometer and the transmission temperature gauge are not shown.

The Recreational Vehicle instrument cluster (ICU3-M2) is an updated version of the basic electronic dashboard (ICU3). It can accept information from the datalink and from various sensors installed on the vehicle, and deliver that information to electronic gauges.

There are six gauges on the driver's instrument panel.

The instrument cluster has the capability to drive independent stand-alone gauges such as those installed on the auxiliary dash panel. [Figure 2.71](#) shows a typical dash.

## Dash Message Center

The dash message center is the heart of the instrument cluster. It has two parts, a set of 26 warning

# Driver Controls and Instruments

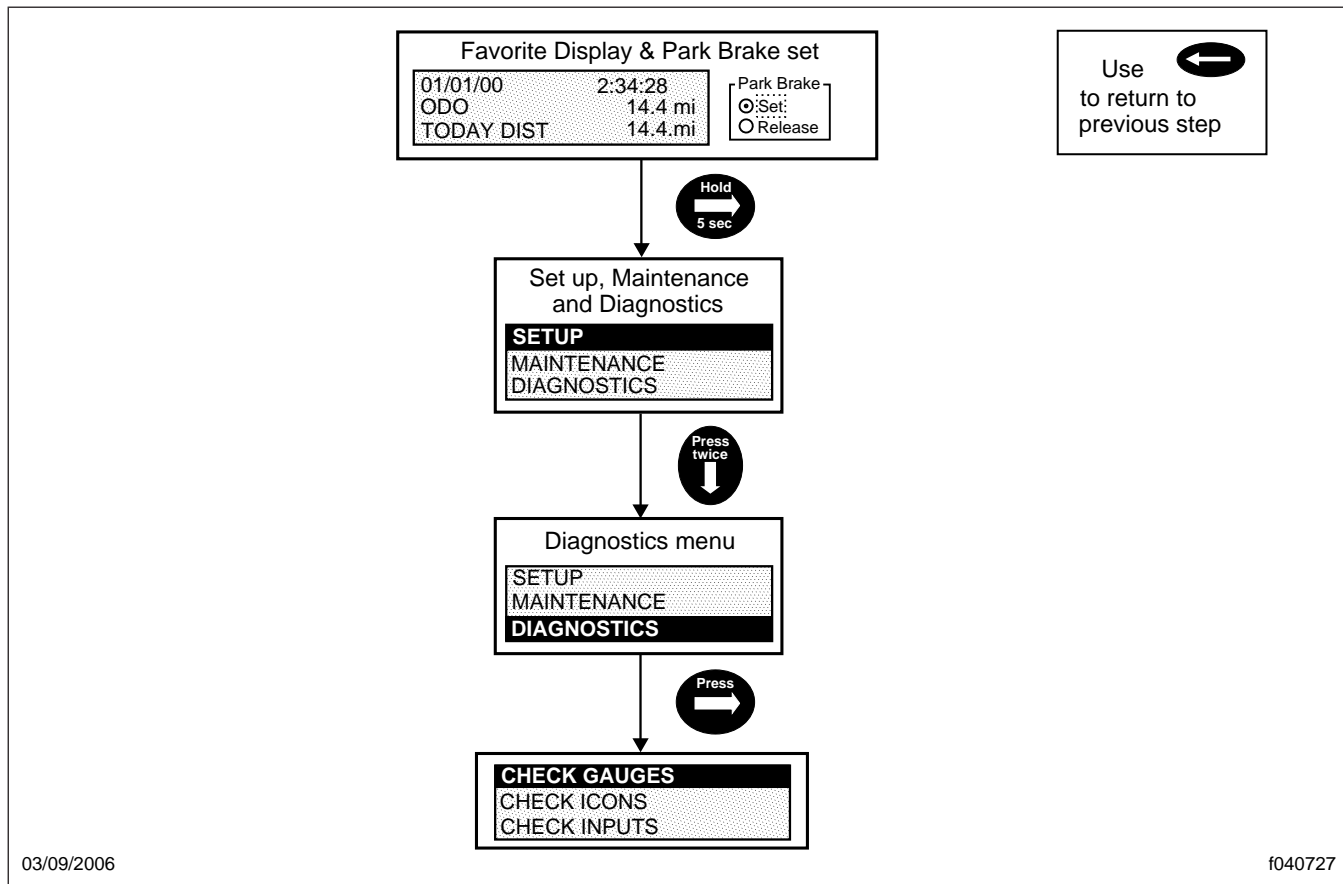

Fig. 2.47, Diagnostics Menu

and indicator lights similar to those found on a conventional lightbar, and a dash driver display screen. The driver display screen is a one-line by seven-character liquid crystal display (LCD) that normally shows odometer readings. Below this display is a smaller one-line by three-character LCD that shows voltmeter readings.

The dash message center houses all of the standard and optional warning and indicator lights. Warning messages and diagnostic fault codes will appear in the driver display screen. For more information on this system, see under the heading "Ignition Sequence" in this chapter.

## Ignition Sequence

The dash message center goes through a prescribed ignition sequence each time the ignition switch is turned on. See [Fig. 2.72](#) for the ignition sequence.

When the ignition is turned on, all the electronic gauges complete a full sweep of their dials, the warning and indicator lights light up, and the buzzer sounds for 3 seconds.

The following lights illuminate during the ignition sequence:

- Fasten Seat Belt Warning
- Low Battery Voltage Warning
- High Coolant Temperature Warning
- Low Engine Oil Pressure Warning
- Parking Brake On Indicator
- All engine indicator/warning lights, including Check Engine and Engine Protection
- All ABS indicator/warning lights, including Wheel Spin, Tractor ABS, and Trailer ABS (if installed)

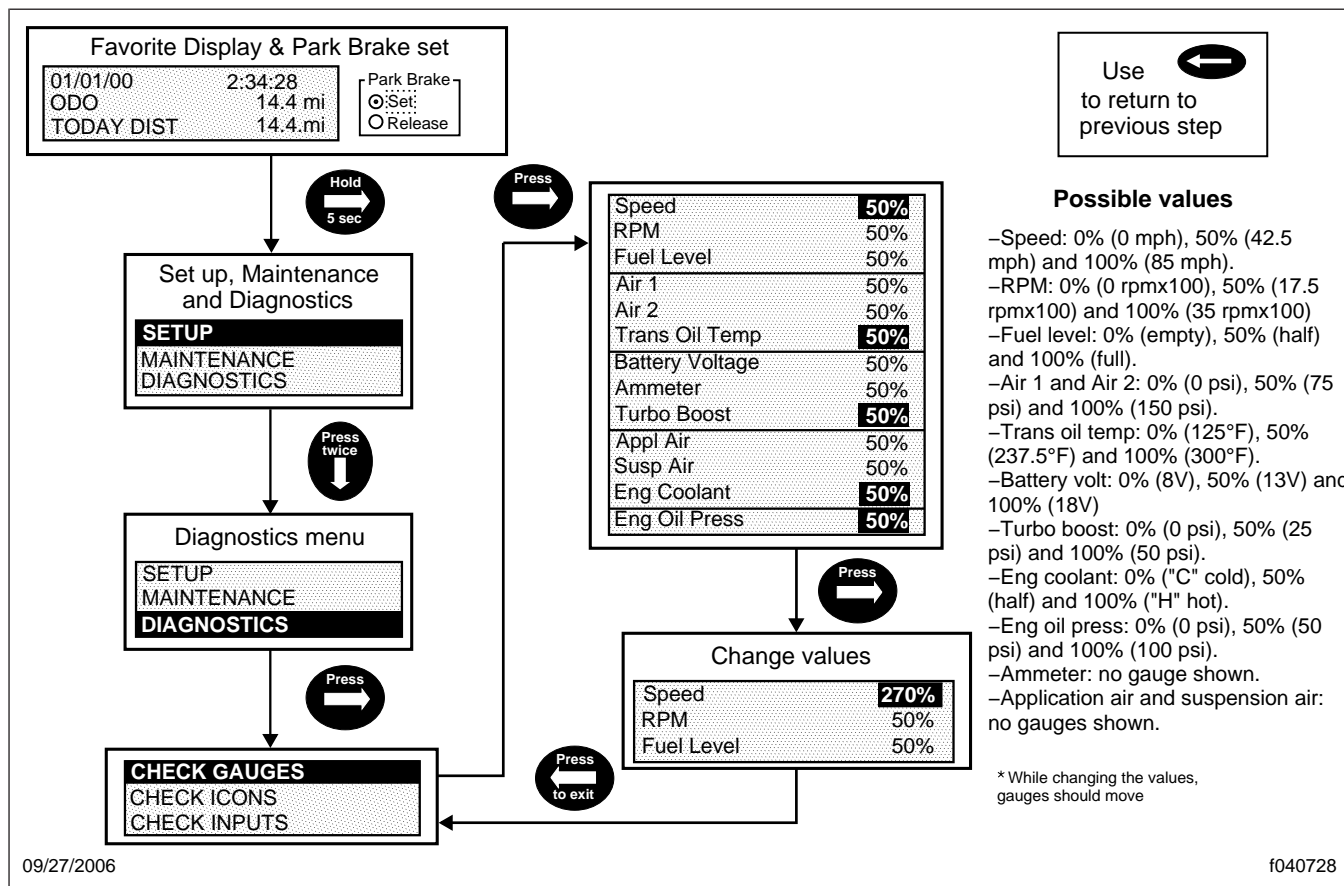

Fig. 2.48, Check Gauges and Change Values

NOTE: While the engine and ABS warning lights illuminate during the ignition sequence, they are not controlled by the instrument cluster but by their own system ECU (electronic control unit). On Caterpillar engines, the engine protection light illuminates when the engine starts, and stays on for about 5 seconds.

When the ignition switch has been turned on, the ICU performs a self-test, looking for active faults. During the first half of the self-test, all segments of the display illuminate as follows:

- First line (odometer): "888888.8"
- Second line (units): "TRIP MI KM HOURS"
- Third line (voltmeter): "38.8 VOLTS SERVICE"
- Fourth line: "ENGINE"

During the second half of the self-test, the software revision level is displayed.

If there are no active faults, the driver display screen displays the odometer.

If the instrument cluster has received active fault codes from other devices, it displays them one after the other until the parking brake is released, or the ignition switch is turned off. Once the parking brake is released, the dash message center displays the odometer again.

NOTE: If active faults are present, take the vehicle as soon as possible to an authorized Freightliner service facility.

If the fault is mission critical, that is, if it is a serious problem that requires immediate attention, the engine protection system will activate. In most cases, the check engine light will illuminate also.

# Driver Controls and Instruments

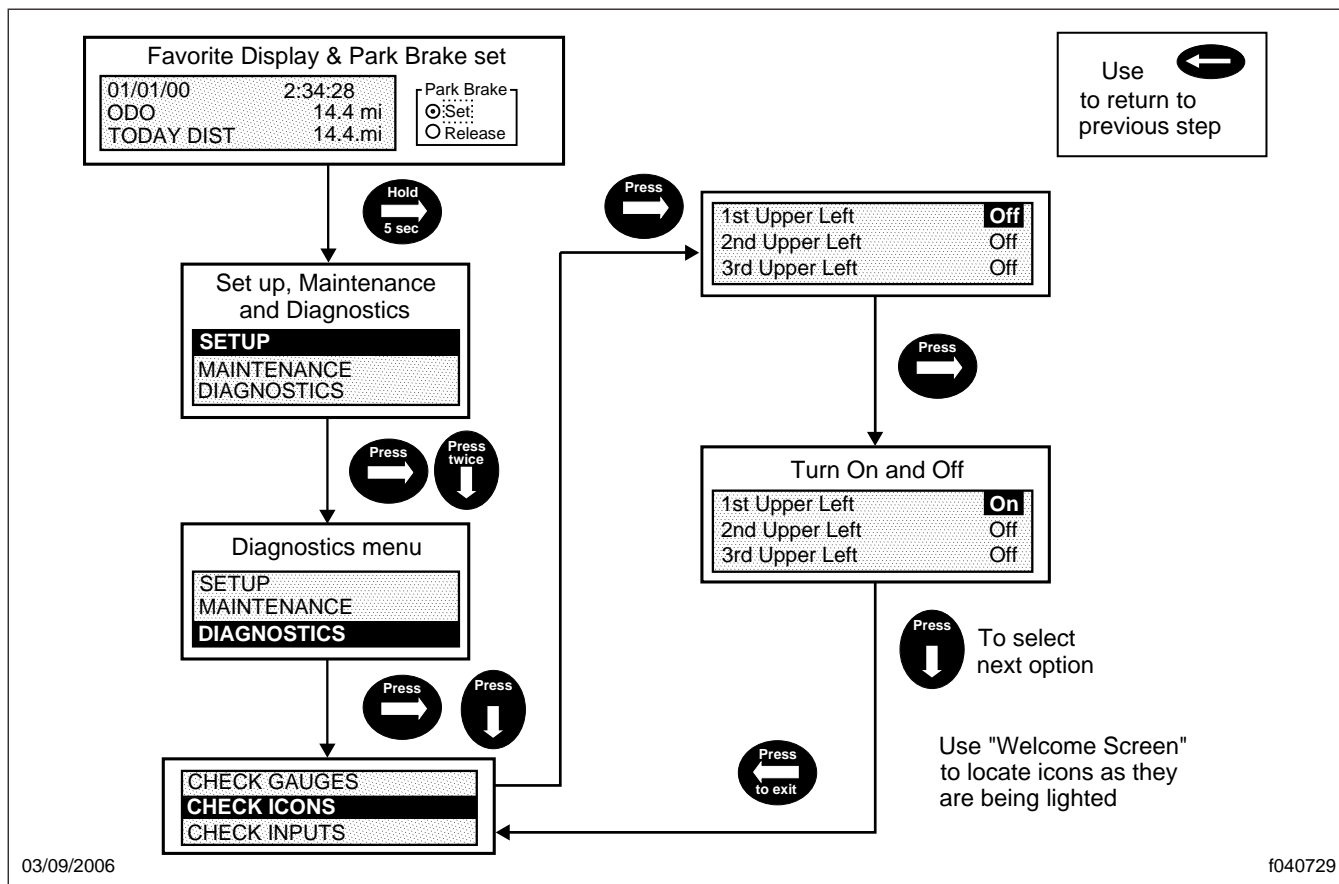

Fig. 2.49, Check Icons and Change Values

Some examples of mission critical faults include:

- High coolant temperature
- Low coolant level
- Low engine oil pressure

NOTE: The check engine light does not illuminate for a low air pressure fault.

The legend "SERVICE ENGINE" can appear on the driver display screen as an active fault code. If this legend appears, it means the trip miles (or hours) have gone beyond the next required service interval, as set by the vehicle operator.

IMPORTANT: If the legend "SERVICE ENGINE" does appear on the driver display screen while operating the vehicle, bring the vehicle to an authorized Freightliner service facility when convenient.

## Odometer

The odometer is set to display in either miles or kilometers, depending on the primary scale of the speedometer. The legend, either "MI" or "KM," illuminates between the odometer and the volts display when the engine is running or the headlights are turned on.

The odometer is a seven-digit display with a decimal point, until the vehicle has traveled 999,999.9 miles or kilometers (km). At one million miles (km), the odometer resets itself to "1000000," without the decimal point, and can continue up to 9,999,999. The odometer only displays significant figures (no leading zeros).

## Mode/Reset Switch

The mode/reset switch is located on the right side of the instrument cluster. See Fig. 2.73. The mode/



# Driver Controls and Instruments

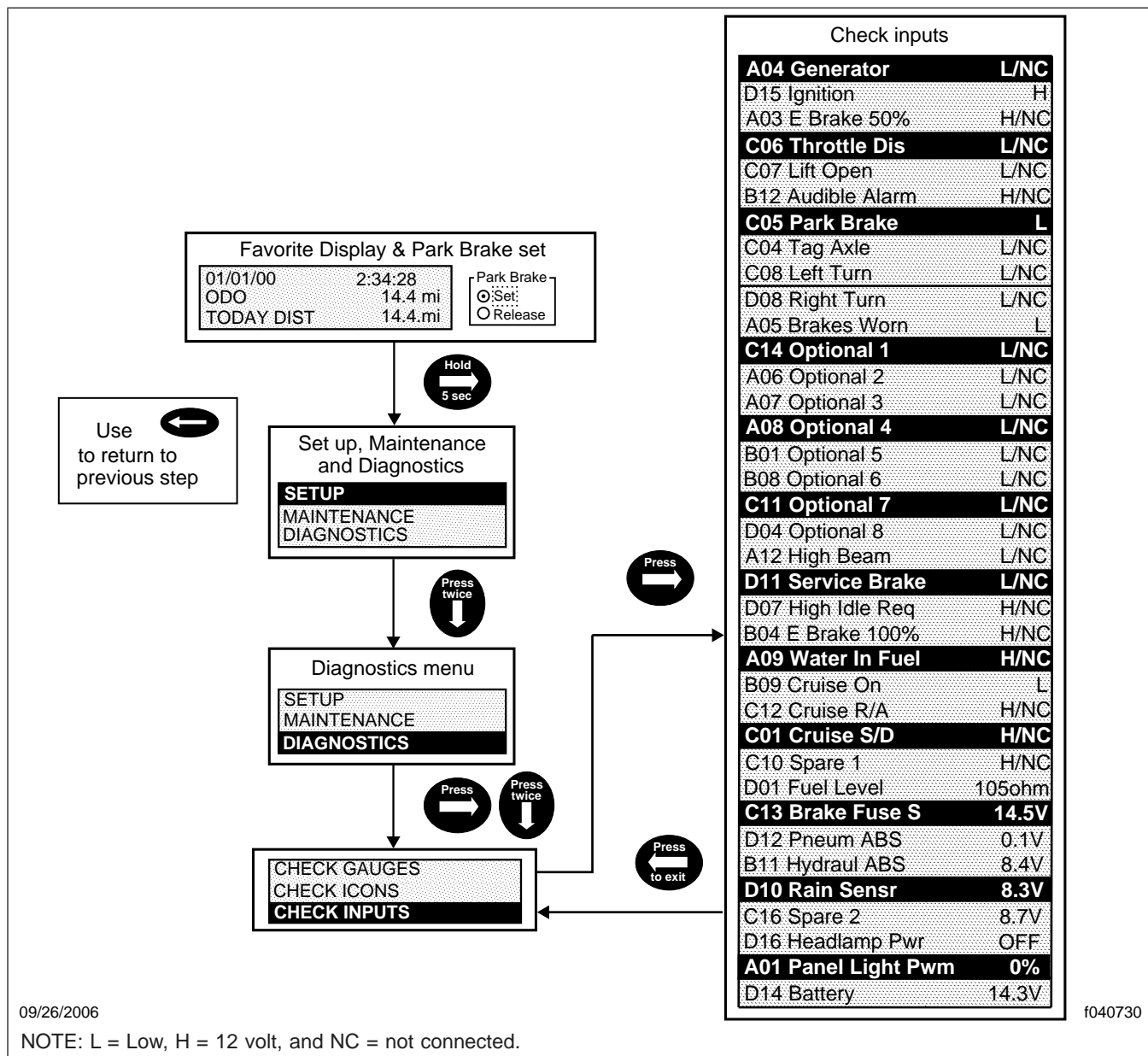

Fig. 2.50, Check Inputs

reset switch is used to scroll through the displays on the message display screen, and to reset the trip distance and trip hours values to zero.

When the odometer reading is displayed and the parking brake is applied:

- Press the mode/reset switch once and the trip distance will display.
- Press the mode/reset switch a second time and the trip hours (engine hours) will display.
- Press the mode/reset switch a third time and the SELECT screen and the current units, MI or KM, will display.
- Press the mode/reset switch a fourth time to return to the odometer reading.

# Driver Controls and Instruments

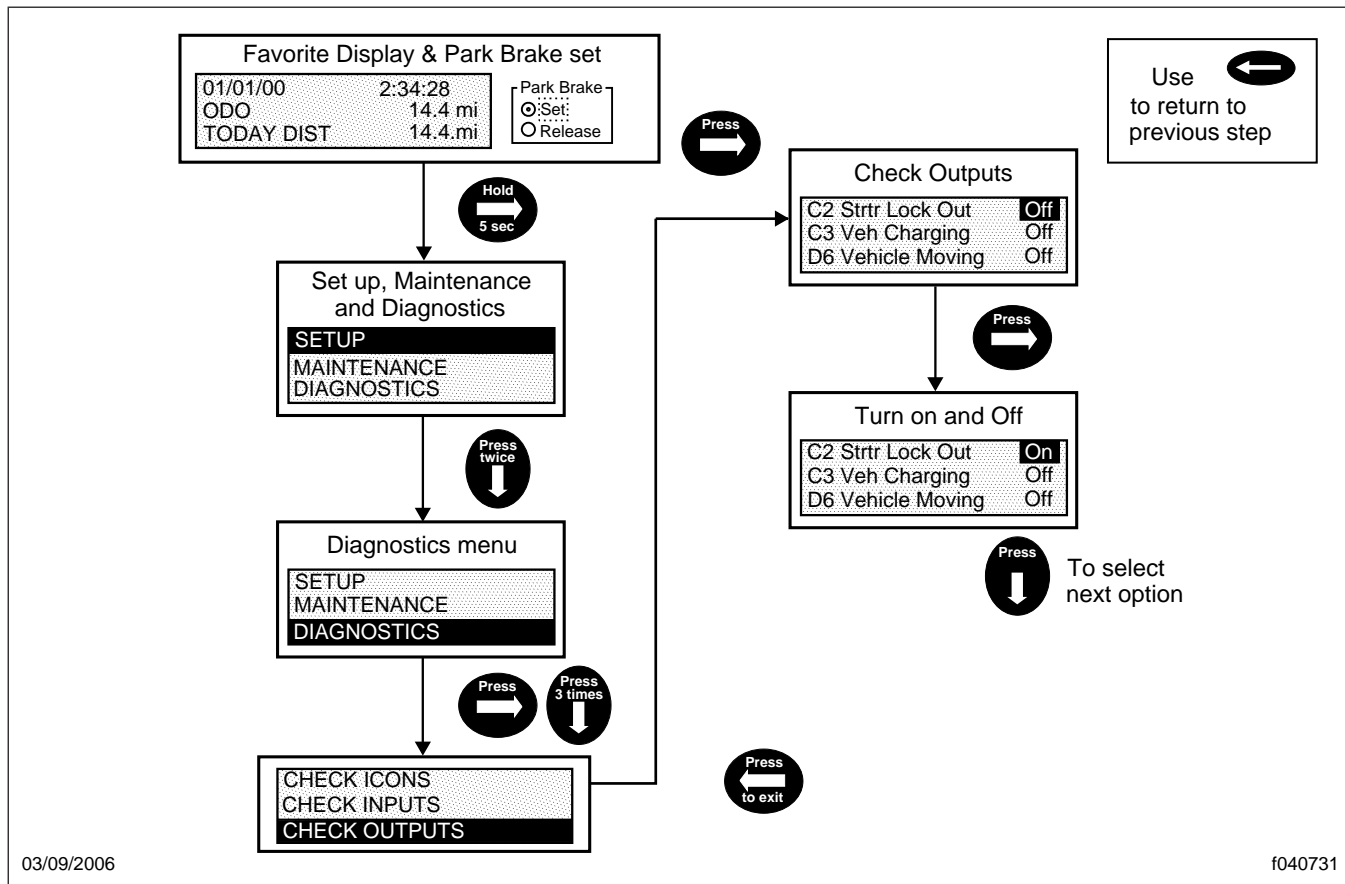

Fig. 2.51, Check Outputs

To reset trip miles and/or trip hours to zero, press the mode/reset switch for 1 second or longer. To toggle between MI (miles) or KM (kilometers), press the mode/reset switch while in the SELECT screen.



# Driver Controls and Instruments

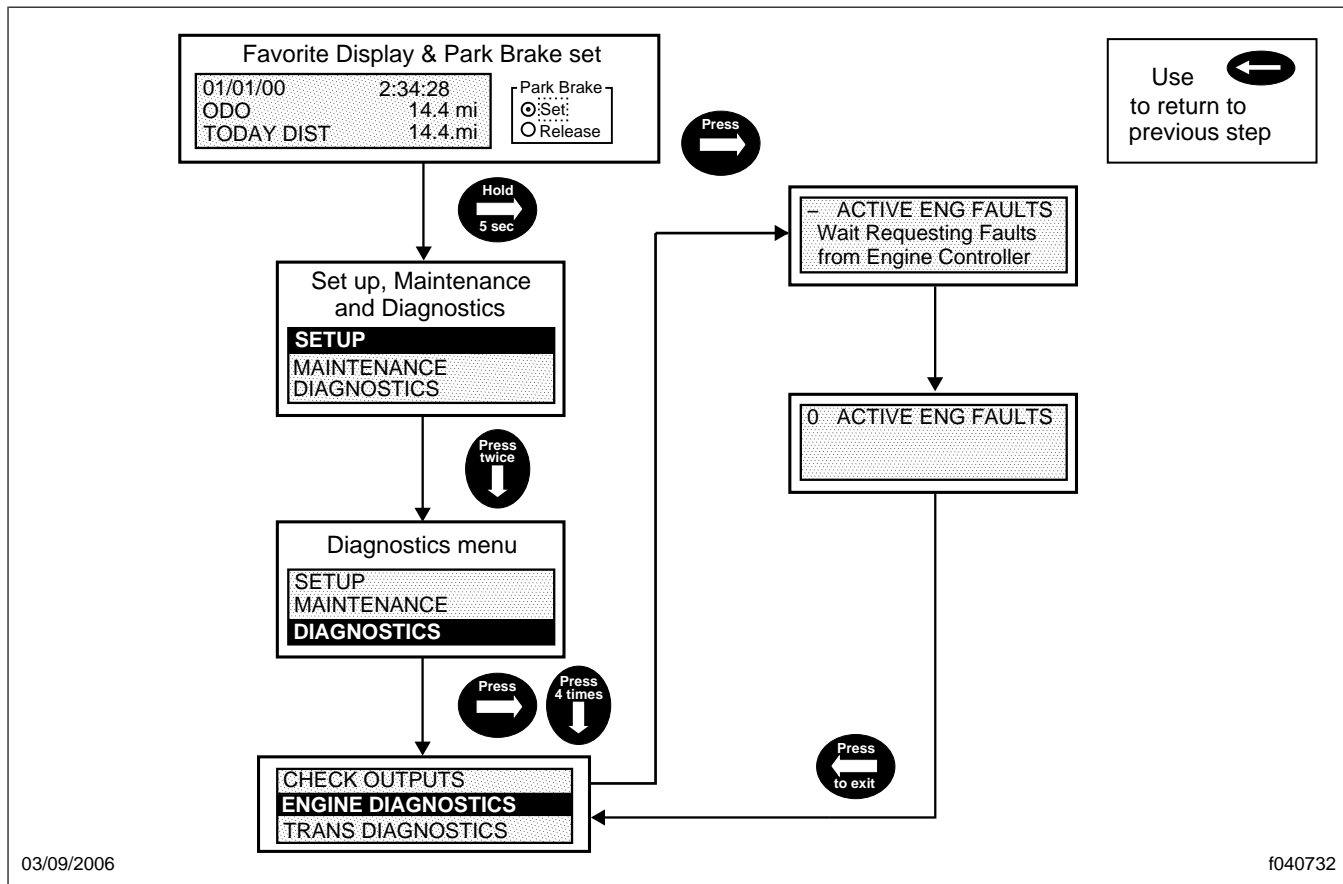

Fig. 2.52, Engine Diagnostics

# Driver Controls and Instruments

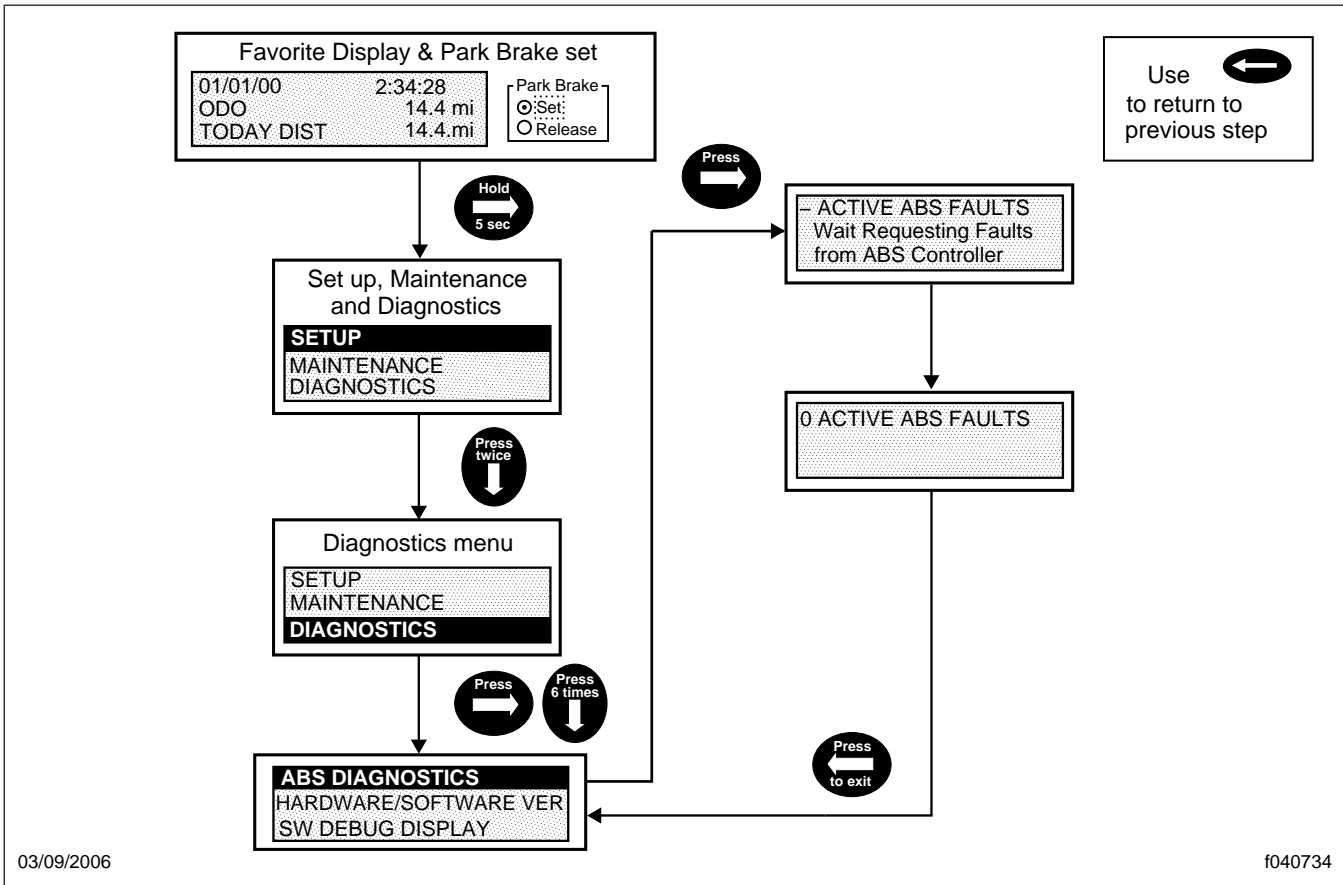

Fig. 2.53, ABS Diagnostics

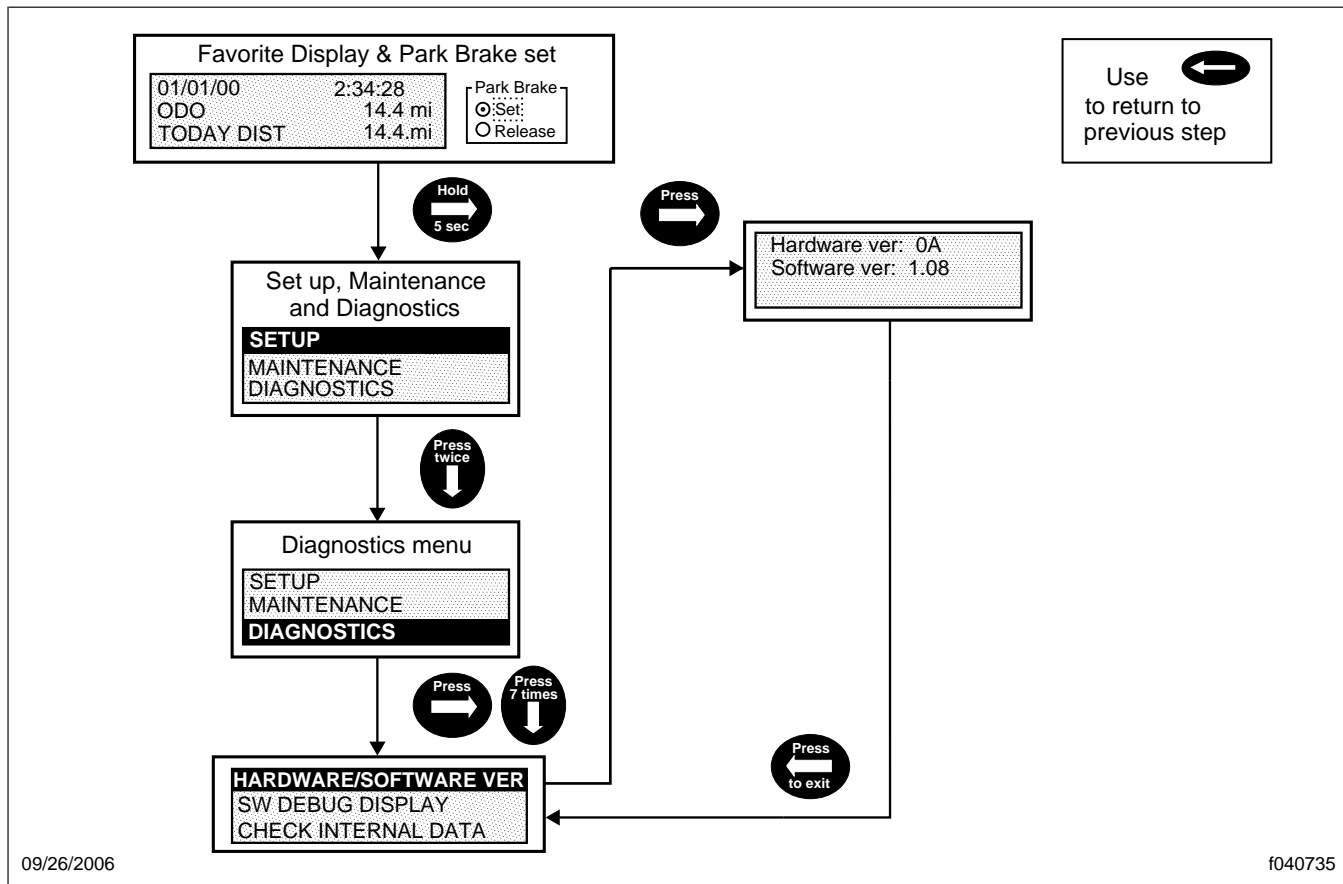

Fig. 2.54, Hardware/Software Menu

# Driver Controls and Instruments

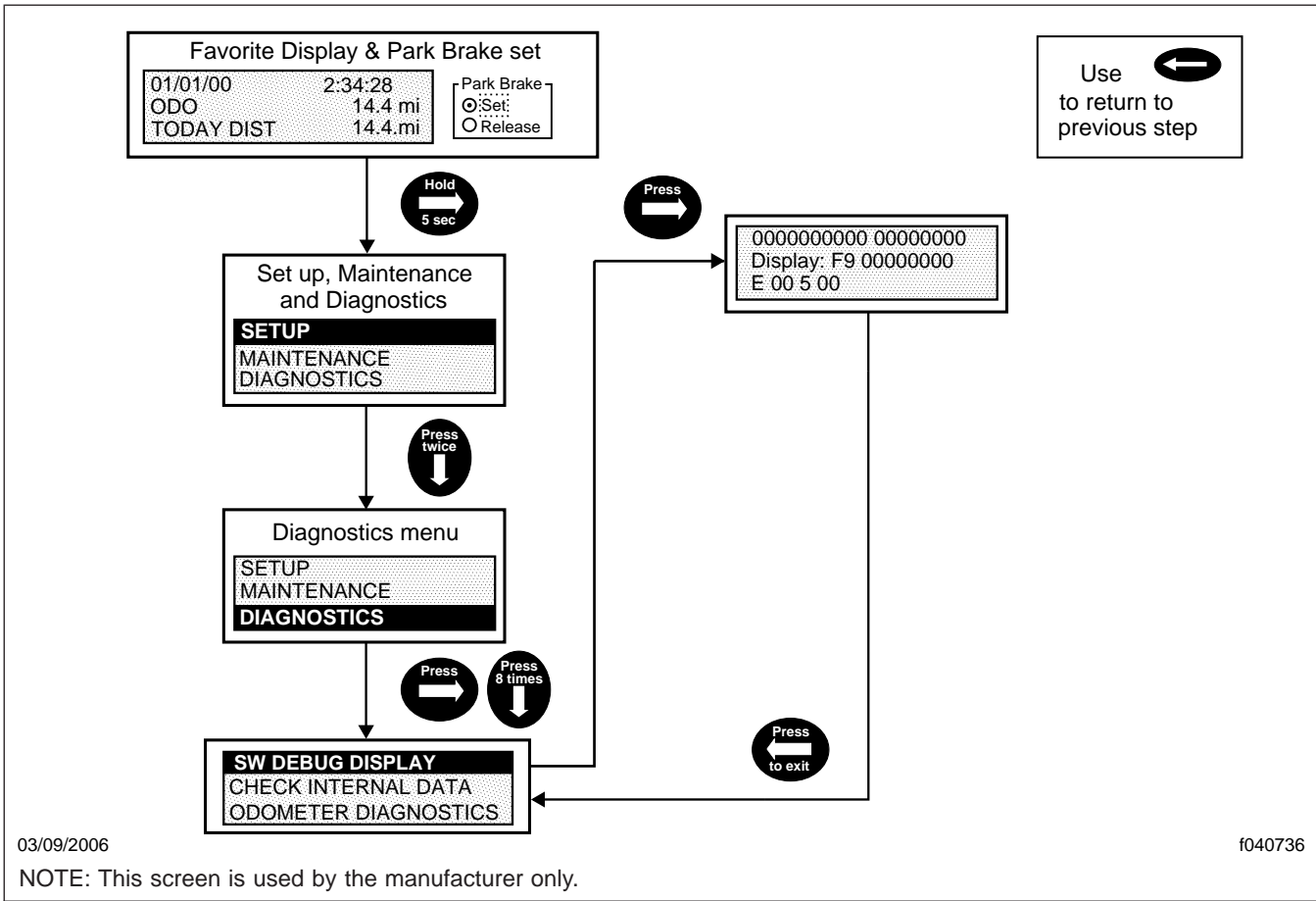

Fig. 2.55, Software Debug Display

# Driver Controls and Instruments

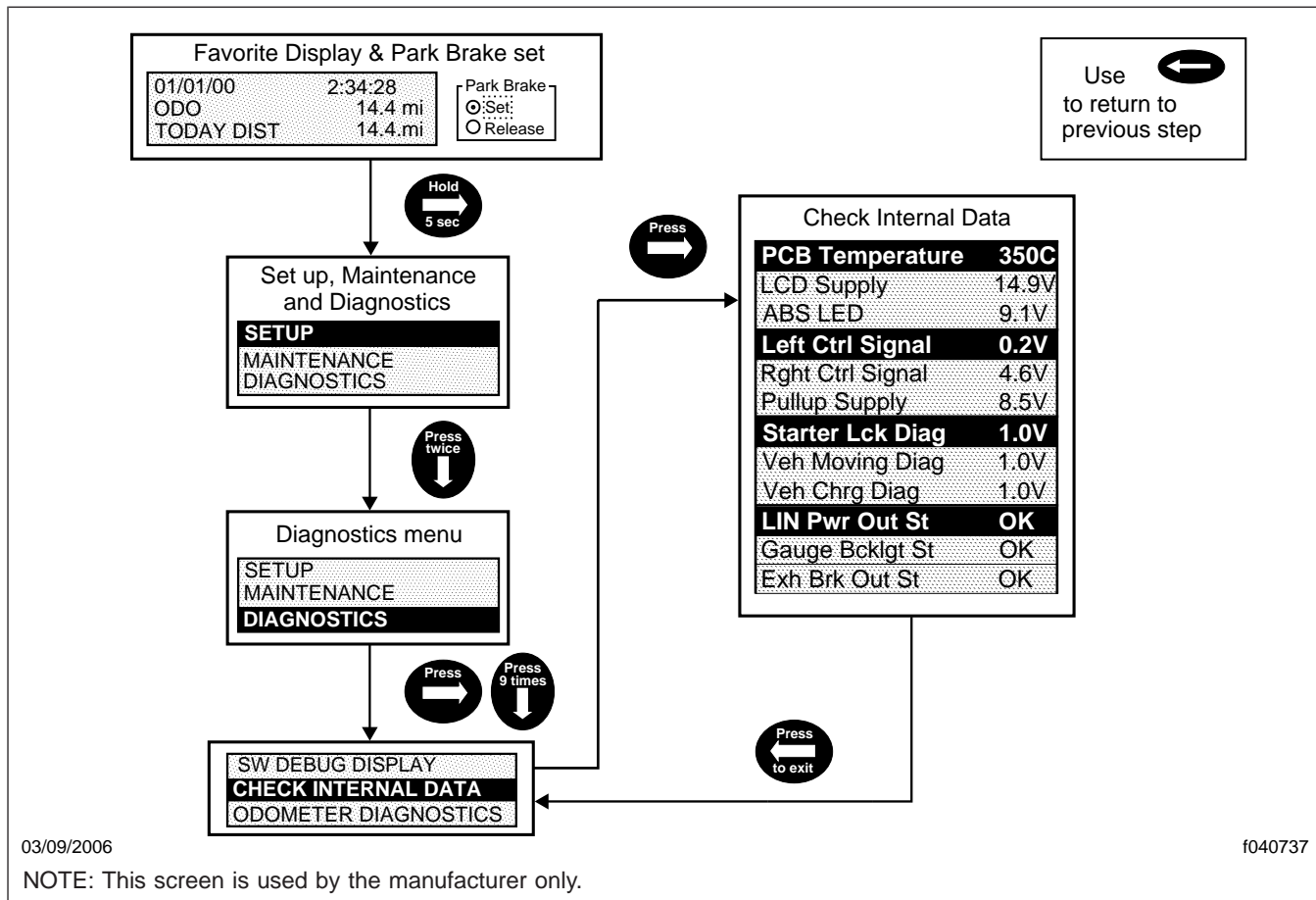

Fig. 2.56, Check Internal Data

# Driver Controls and Instruments

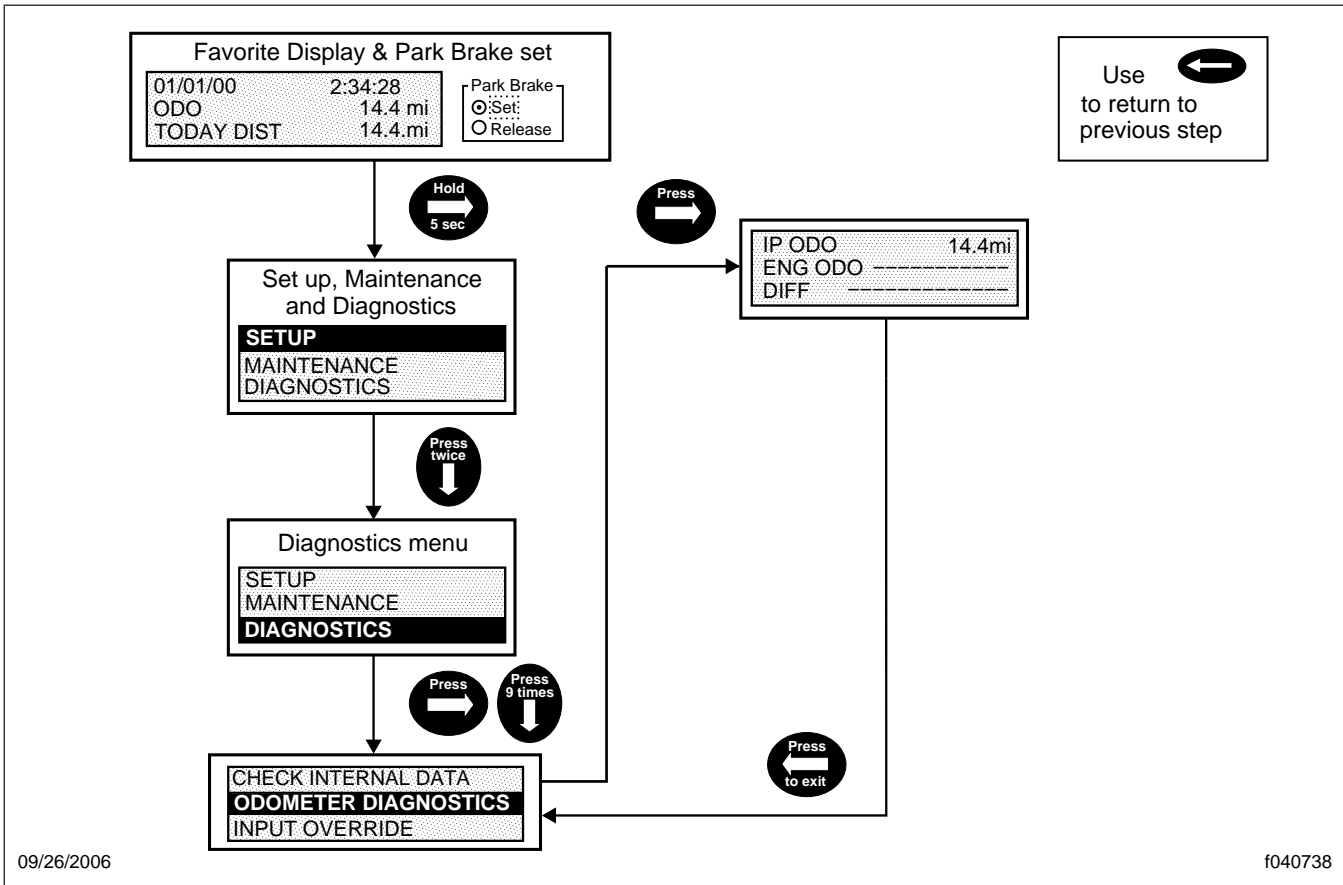

Fig. 2.57, Odometer Diagnostics

# Driver Controls and Instruments

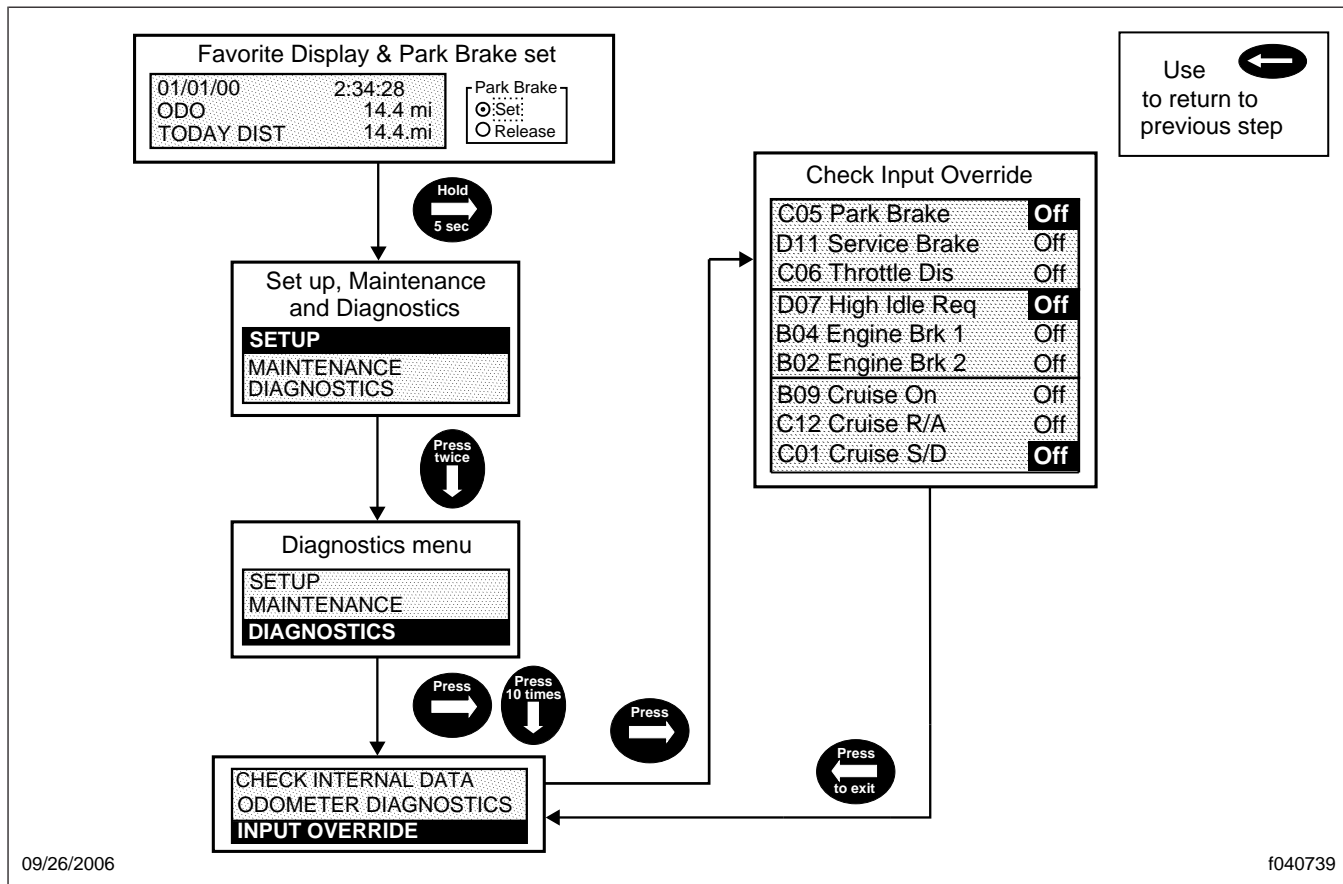





Fig. 2.58, Check Input Override



# Driver Controls and Instruments

1	2	3	4	5	6	7	8	9	10	11	12
	STOP ENGINE	CHECK ENGINE	CHECK TRANS	ABS			LOW AIR	ENG PROT	PARK BRAKE		
				WAIT TO START			CHECK INFO CENTER		CRUISE ON	SHIFT INHIBIT	
24	23	22	21	20	19	18	17	16	15	14	13

10/07/2003 f610671

1. Left-Turn Signal Indicator	9. Engine Protection Warning Light	17. Check Info Center Indicator Light
2. Stop Engine Warning Light	10. Parking Brake Indicator Light	18. Blank Position
3. Check Engine Warning Light	11. Blank Position	19. Blank Position
4. Check Transmission Warning Light	12. Right-Turn Signal Indicator Light	20. Wait to Start Warning Light
5. ABS Warning Light	13. Blank Position	21. Blank Position
6. High-Beam Indicator Light	14. Shift Inhibit Warning Light	22. Blank Position
7. Blank Position	15. Cruise Control Indicator Light	23. Blank Position
8. Low Air Warning Light	16. Blank Position	24. Blank Position

**Fig. 2.59, Annunciator Module, Pre-2007**

# Driver Controls and Instruments

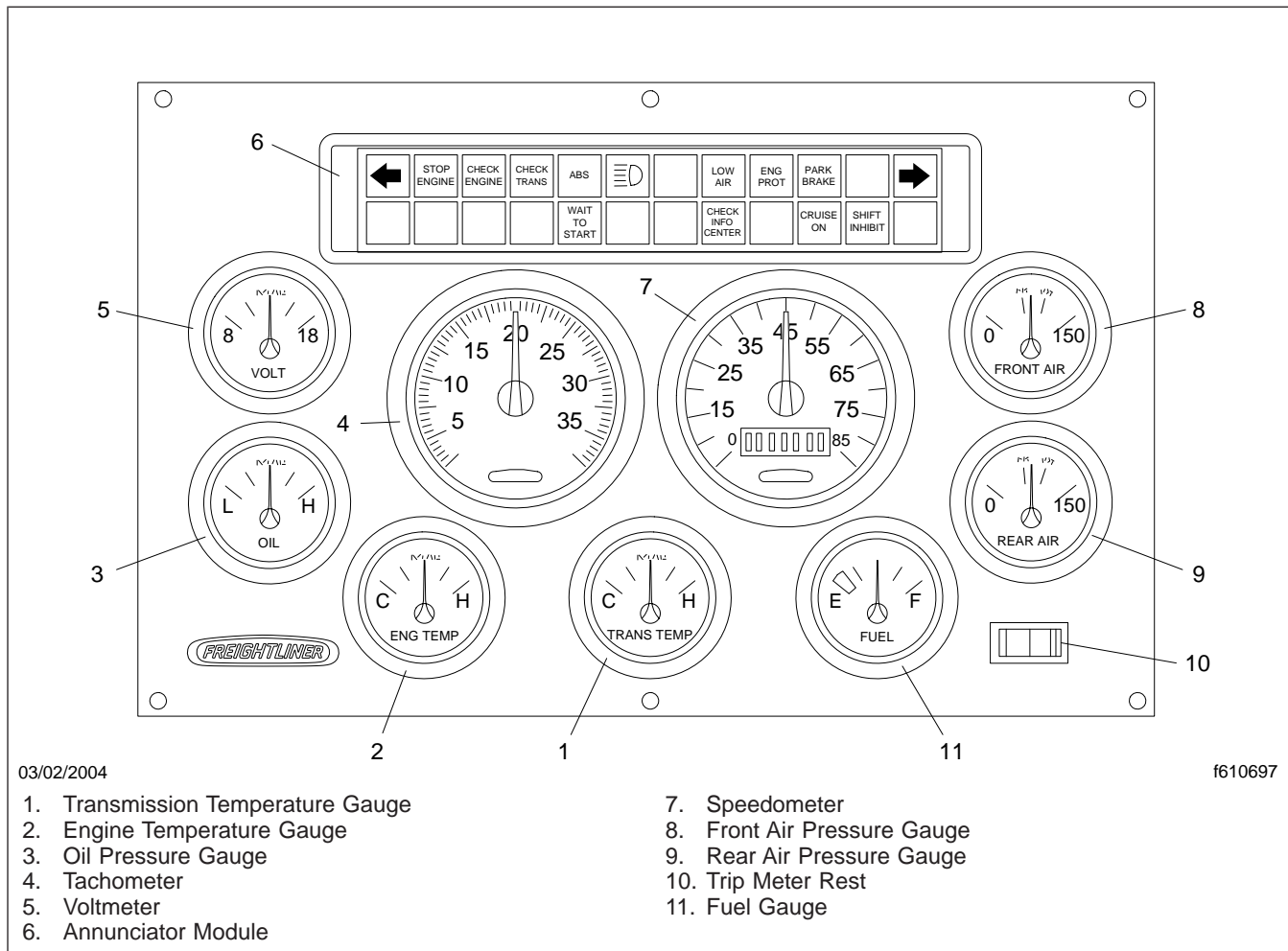

Fig. 2.60, Typical Instrument Panel, Pre-2007

# Driver Controls and Instruments

Symbol	Name	Purpose
↑	Scroll Up	Highlights the line above
↓	Scroll Down	Highlights the line below
E	Enter	Selects highlighted line
T	Toggle	Cycles through screens within a menu
⦿	Red Button	Jumps to Favorite Screen
H	Home	Returns to the previous menu

03/01/2004

f060185

Fig. 2.61, Information Center Menu Options

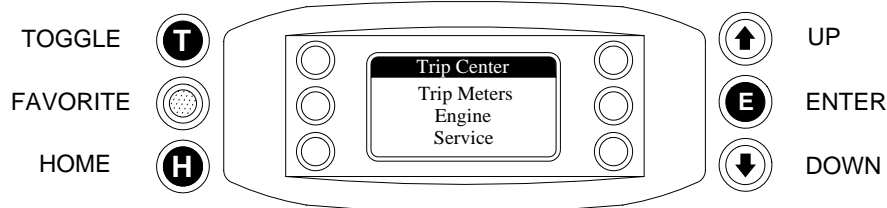

Use the "UP" or "Down" arrows to highlight the desired menu option. To enter the selected menu option press "E". To return to the previous menu, press "H".

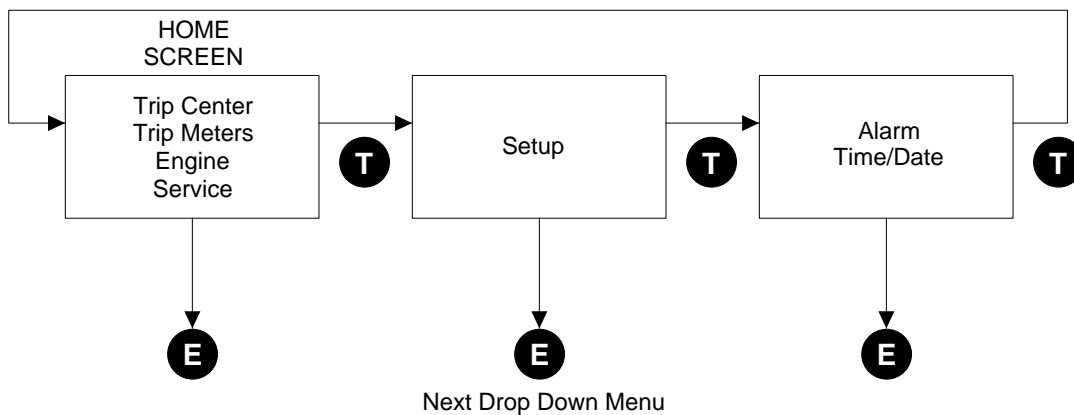

02/27/2004

f544414

Fig. 2.62, Home Screen

# Driver Controls and Instruments

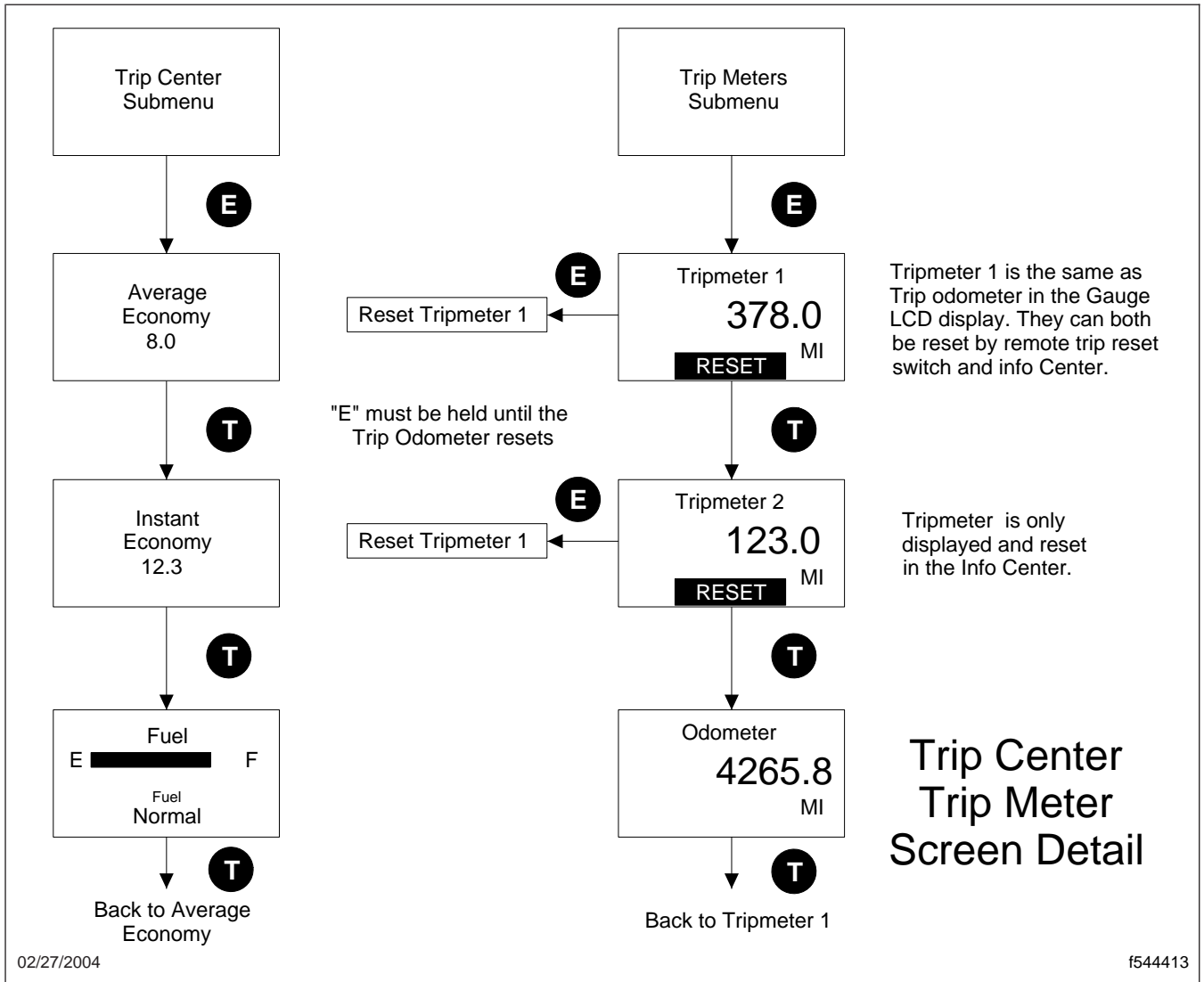

Fig. 2.63, Trip Center/Trip Meter Detail

# Driver Controls and Instruments

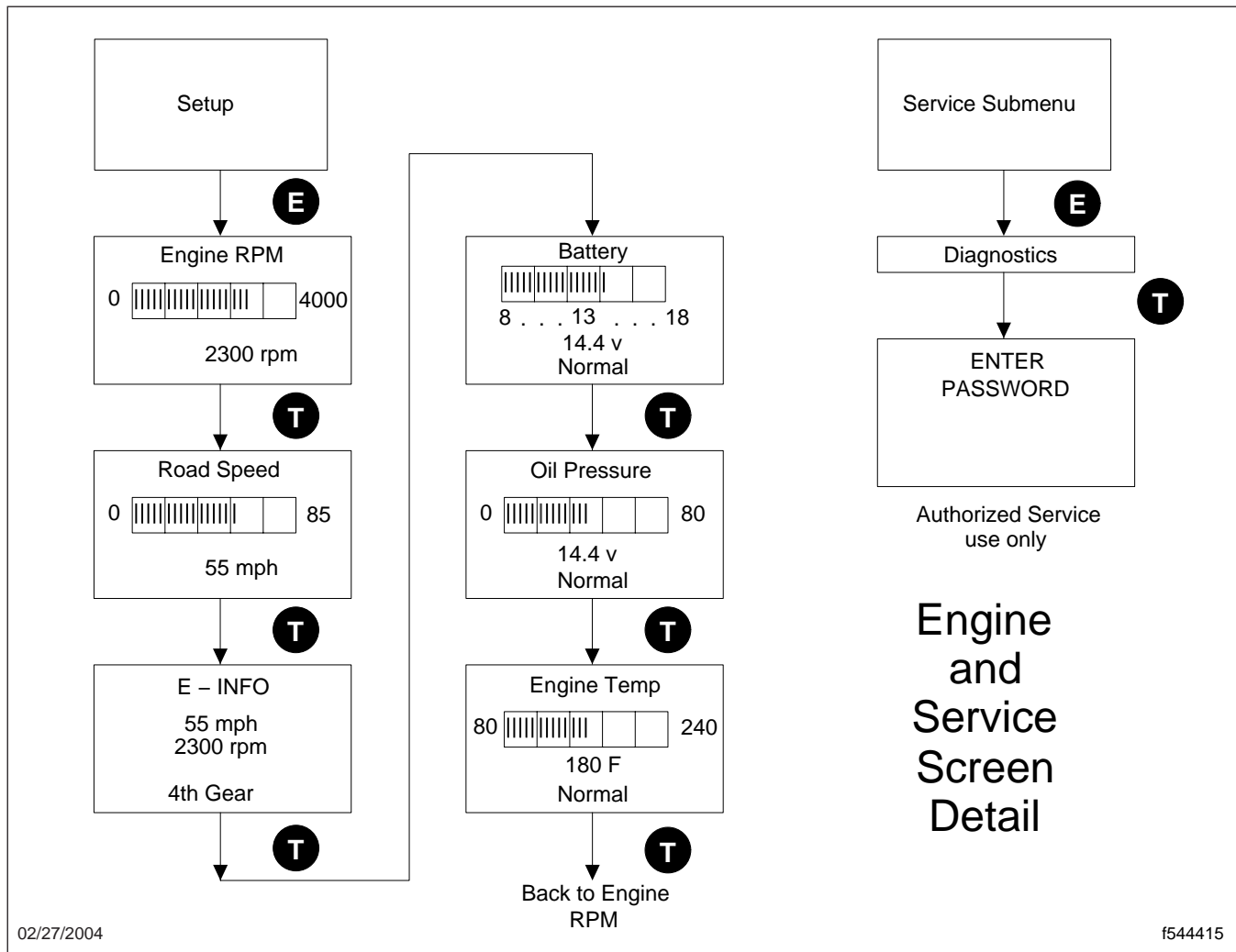

Fig. 2.64, Engine and Service Screen Detail

# Driver Controls and Instruments

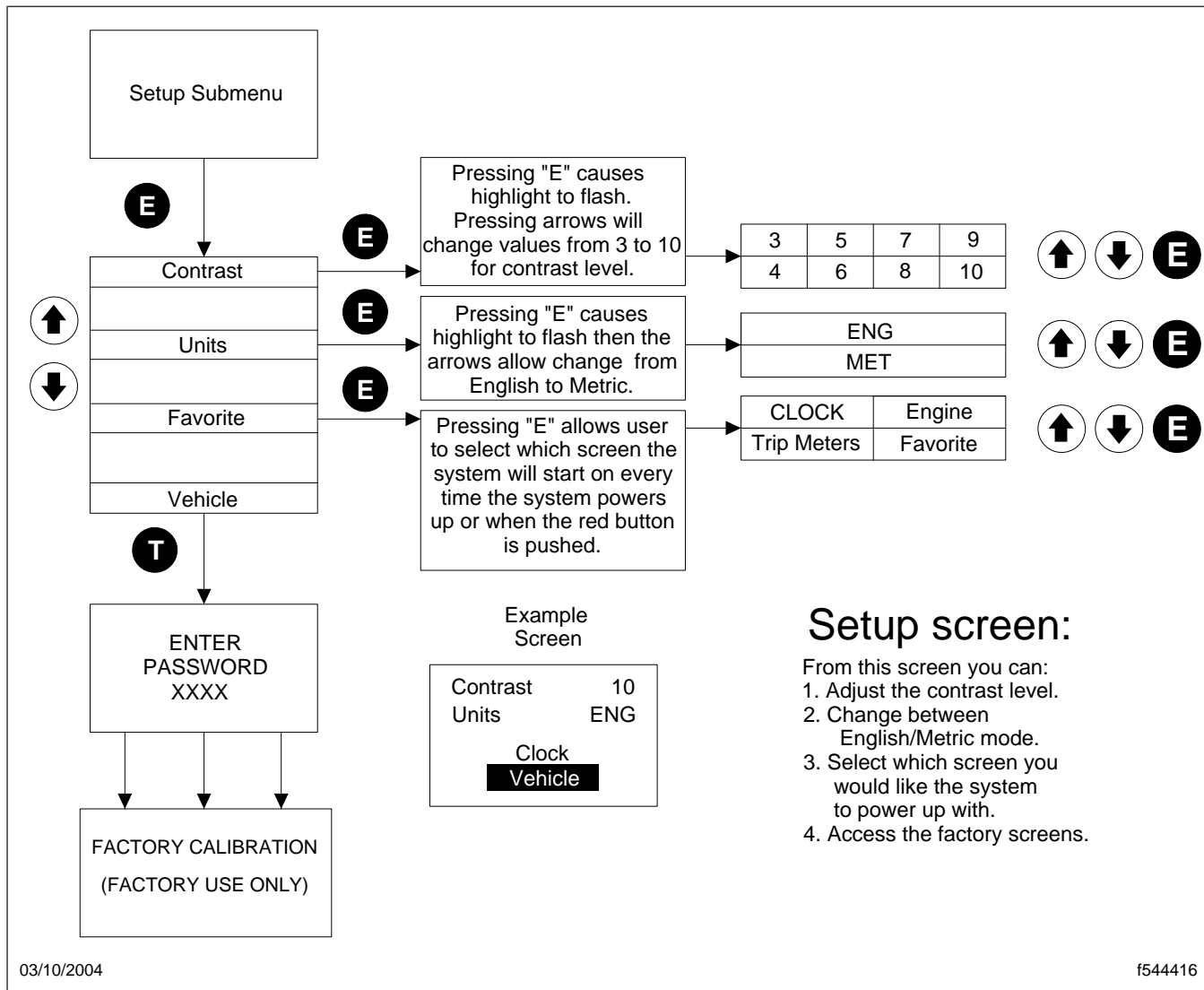

Fig. 2.65, Setup Screen

# Driver Controls and Instruments

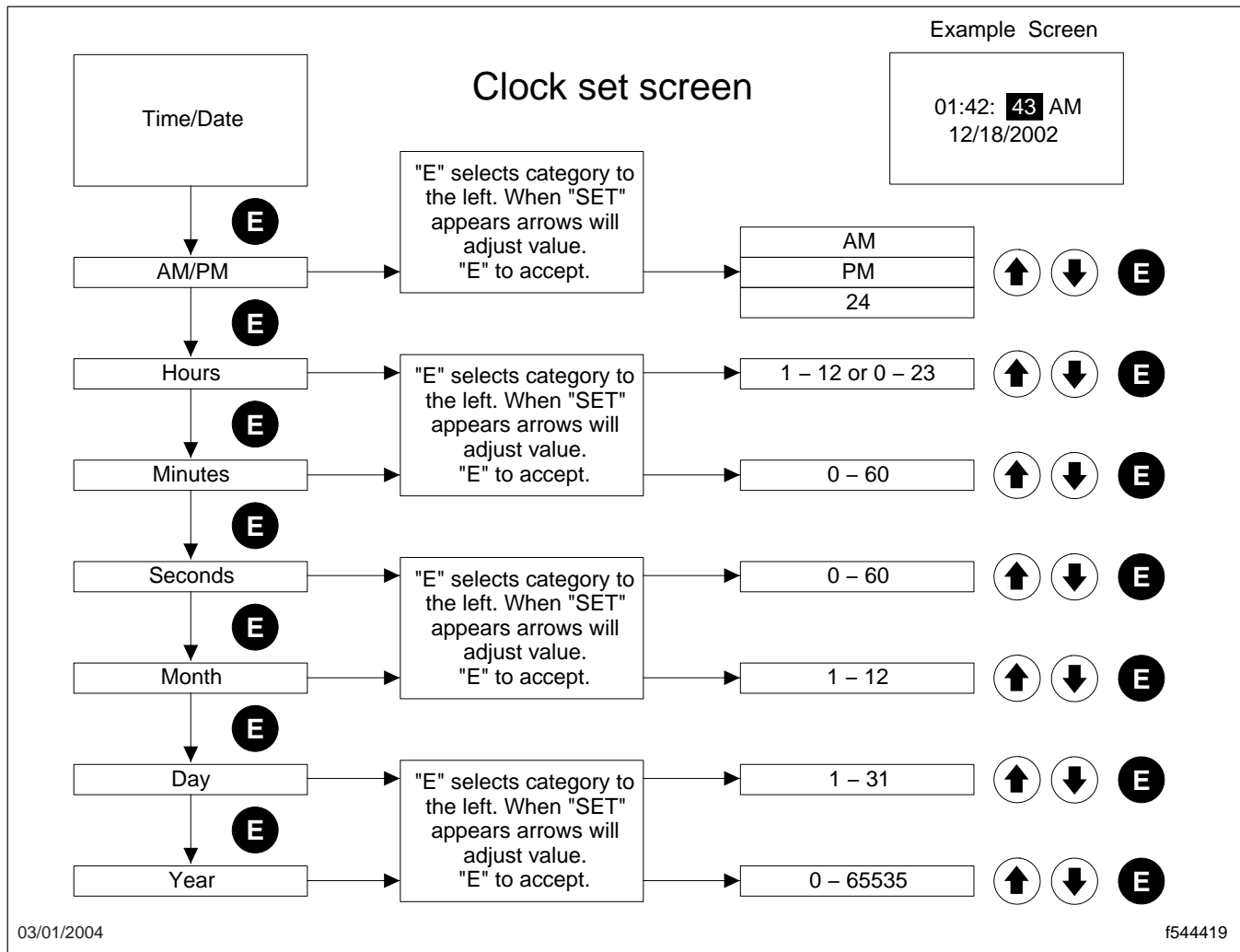
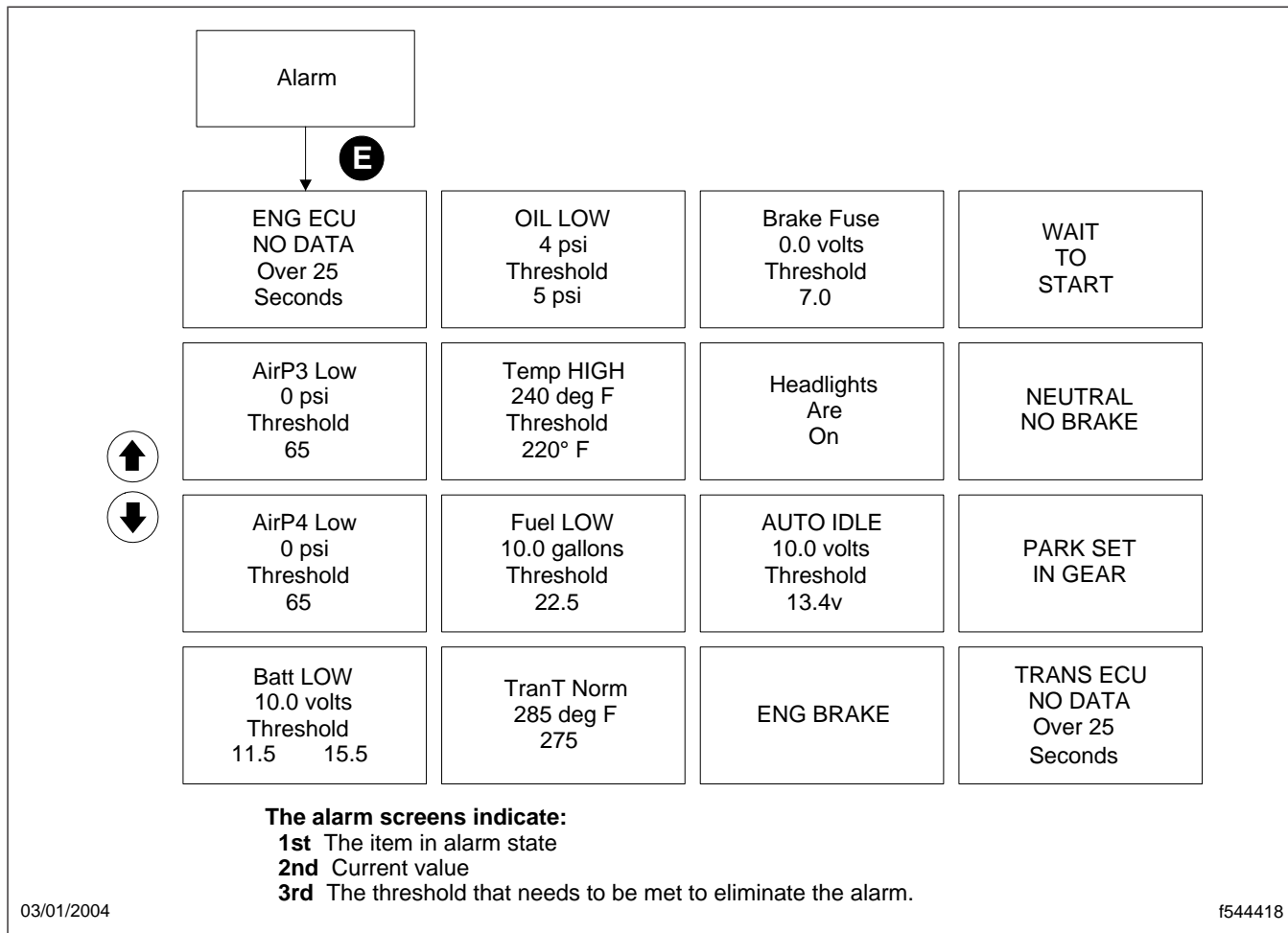

Fig. 2.66, Clock Set Screen



# Driver Controls and Instruments



03/01/2004

f544418

Fig. 2.67, Alarm Screen

# Driver Controls and Instruments

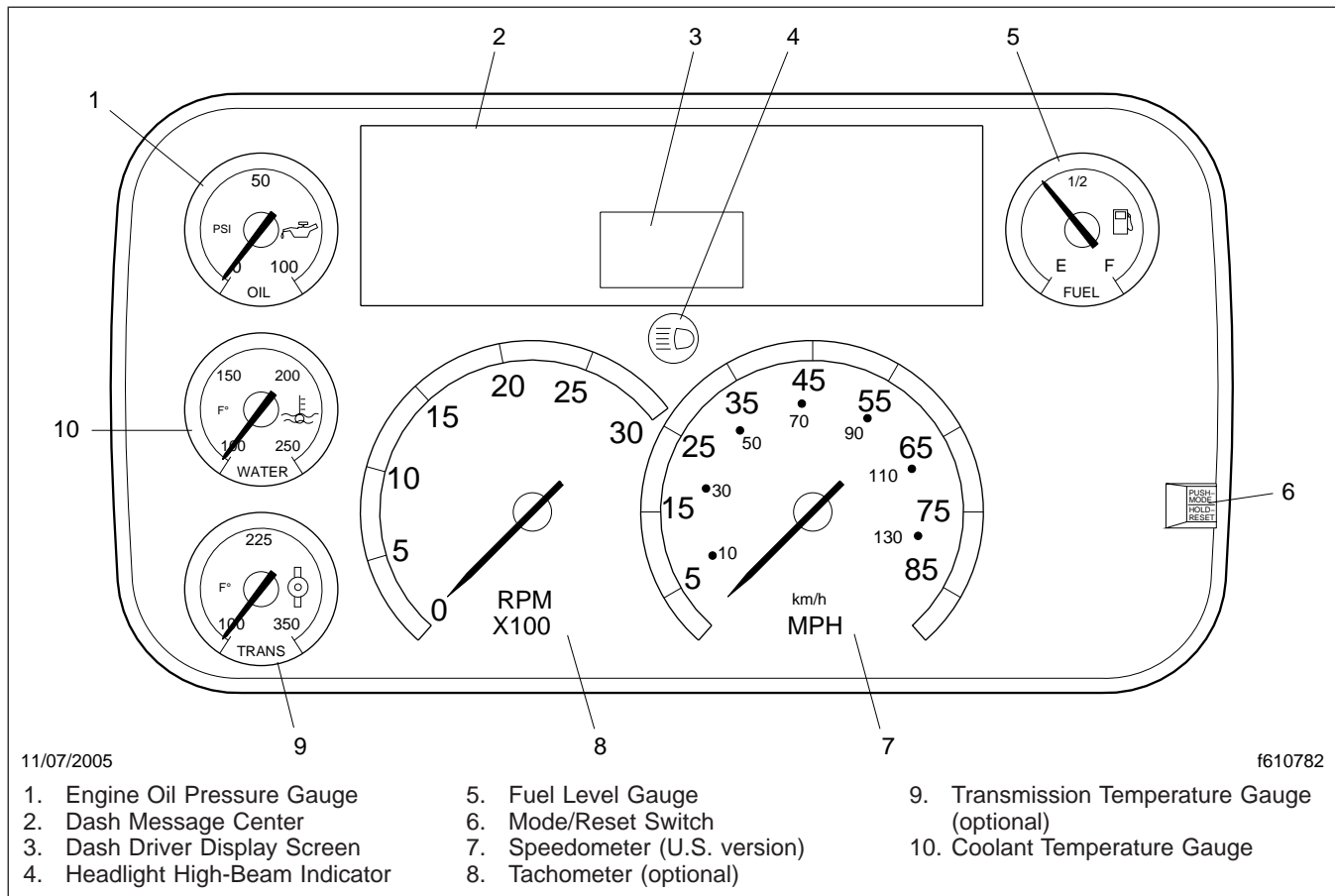

**Fig. 2.68, Gauge Layout (typical, U.S.), Pre-2007**

# Driver Controls and Instruments

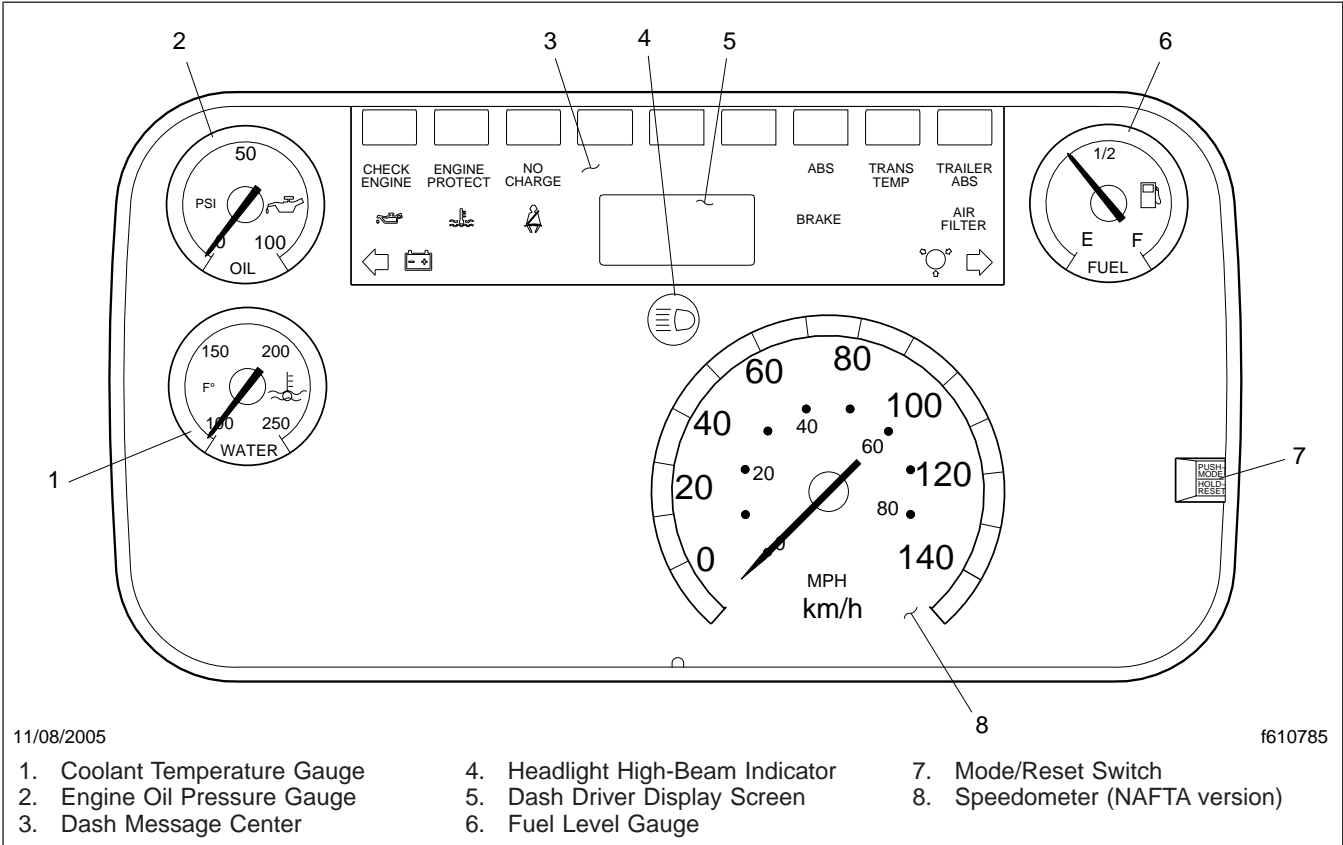

**Fig. 2.69, Gauge Layout (basic), Pre-2007**

# Driver Controls and Instruments

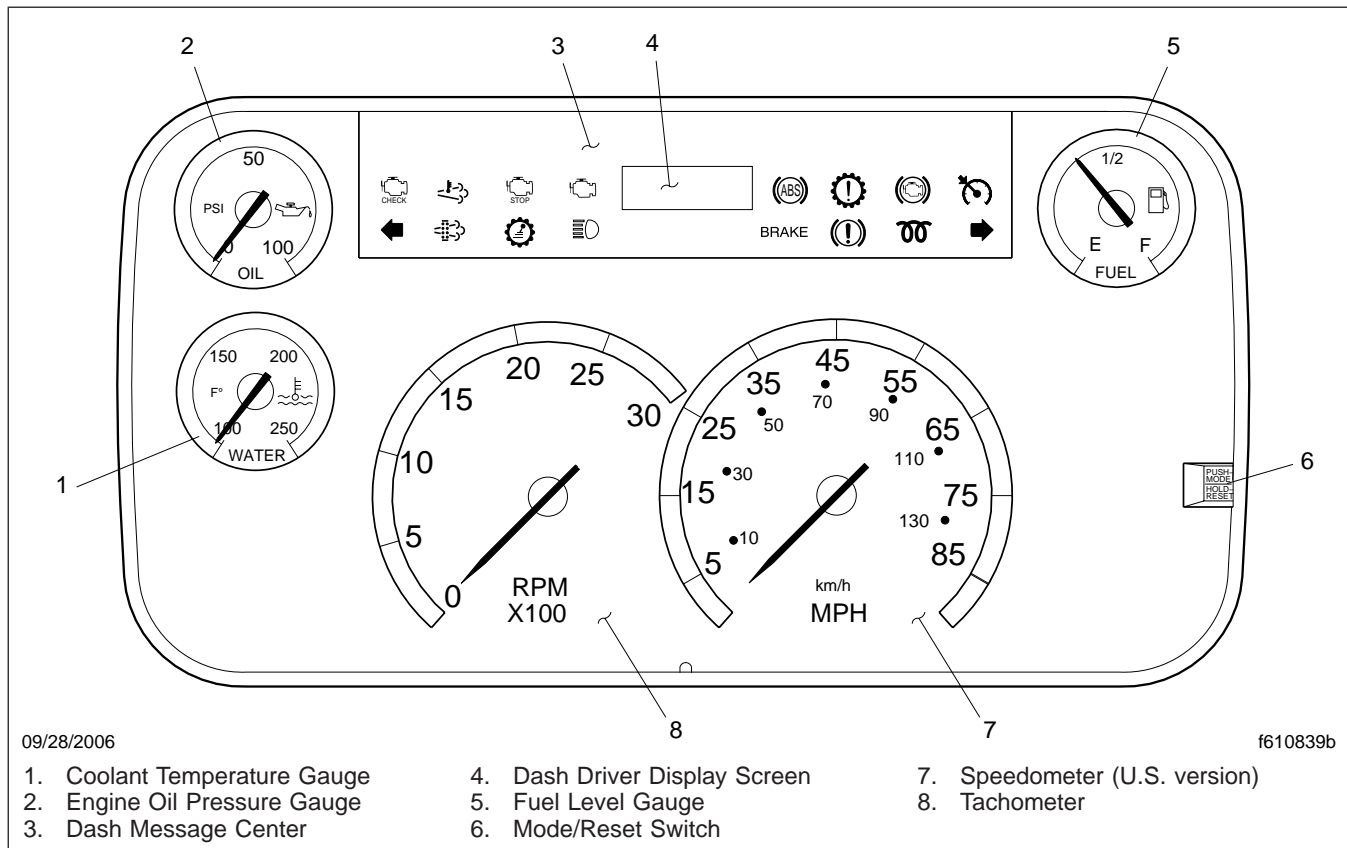

**Fig. 2.70, Gauge Layout (basic), EPA07 Compliant**

# Driver Controls and Instruments

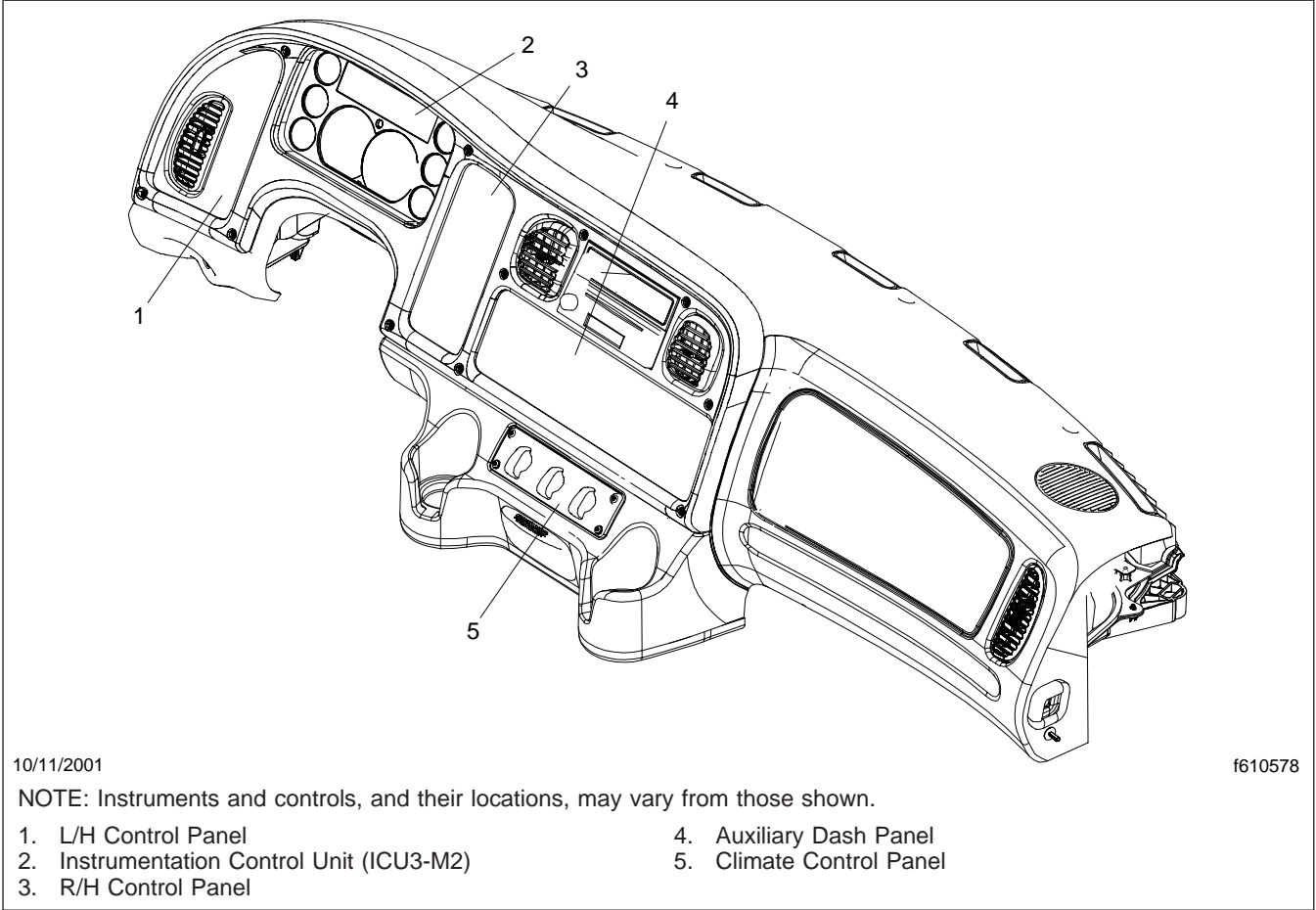

**Fig. 2.71, Dash Panel Layout (typical)**

# Driver Controls and Instruments

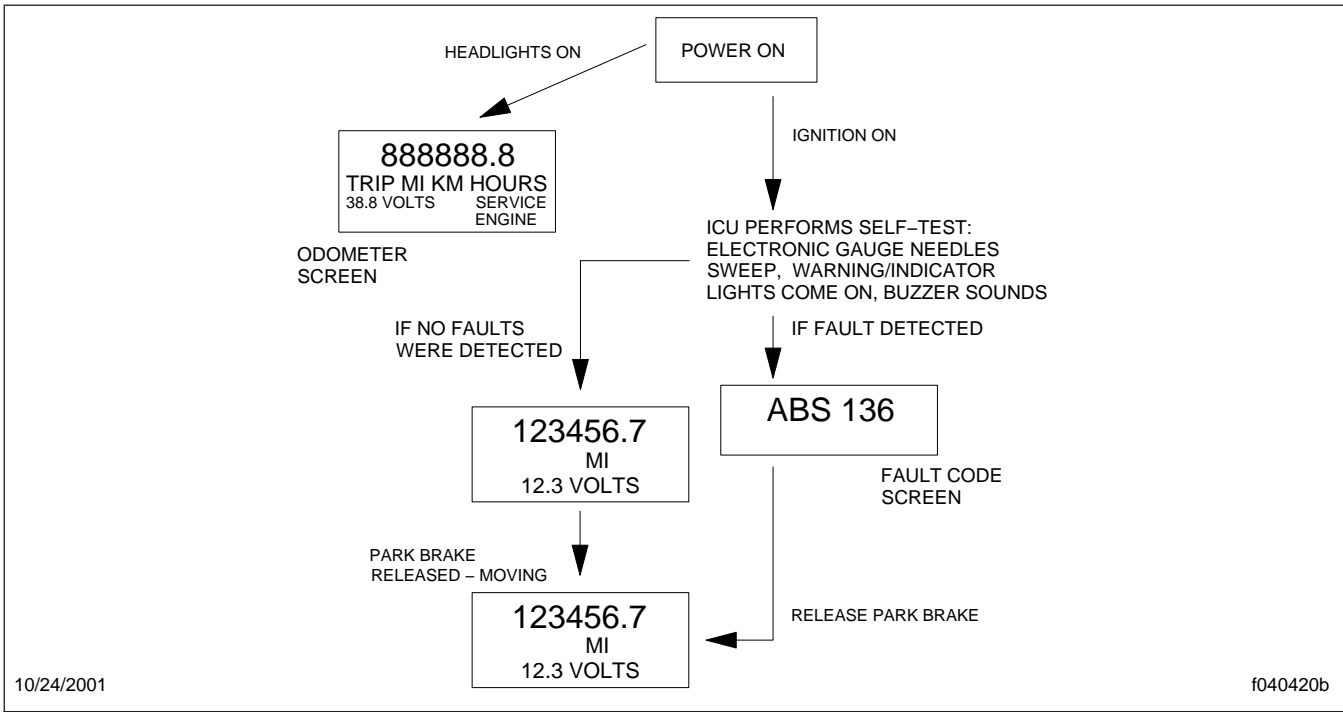

Fig. 2.72, Ignition Sequence

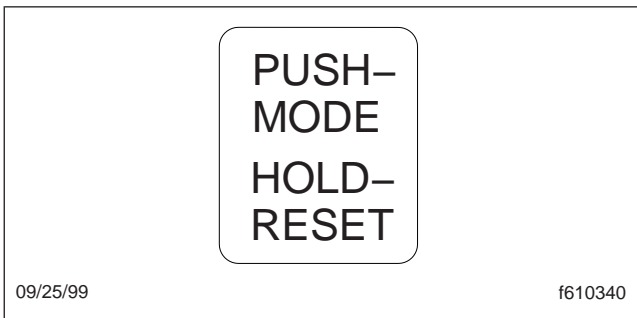

Fig. 2.73, Mode/Reset Switch

# 3

## Engines

---

EPA07 After-Treatment System (ATS) .....	3.1
Engine Starting .....	3.2
Cold Weather Operation .....	3.3
Engine Operation .....	3.3
Cruise Control .....	3.5
Engine Shutdown .....	3.7
High Altitude Operation .....	3.9
Engine Braking (optional) .....	3.9



# Engines

## EPA07 After-Treatment System (ATS)

All on-road diesel engines built after December 31, 2006 (EPA07 engines) must meet strict new guidelines for reduced emissions of particulate matter and nitrogen oxides (NOx) from the exhaust. NOx is limited to just over 1 gram per brake horsepower hour (g/bhp-hr) and particulate matter cannot exceed 0.01 g/bhp-hr.

EPA07 compliant engines require ultralow-sulfur diesel (ULSD) fuel, and they should never be run on fuel with sulfur content higher than 15 ppm. In addition, they require low-ash engine oil. The following guidelines must be followed or the warranty may be compromised.

- Use ultralow-sulfur diesel (ULSD) with 15 ppm sulfur content or less, based on ASTM D2622 test procedure.
- Do not use fuel blended with used engine lube oil.
- Engine lube oil must have a sulfated ash level less than 1.0 wt %; currently referred to as CJ-4 oil.

Vehicles with EPA07 compliant engines, are equipped with an after-treatment system that has a diesel particulate filter in place of a muffler. Particulate matter is collected in the filter, then reduced to ash in a process called regen (regeneration). Regen usually occurs during the normal operation of the vehicle, and the operator should see no difference in vehicle performance. However, a vehicle that performs mainly short trips, may not sustain exhaust temperatures sufficiently high for an automatic regen to occur. In that case it may be necessary to perform a manual regen. See the engine operation manual for complete details and operation of the after-treatment system.

There are three warning lamps in the driver message center that alert the driver of the need to perform a manual regen, clean the filter, or of an engine fault that affects the emissions.

### **WARNING**

**When the HEST lamp is on, be certain that the exhaust pipe outlet is not directed at combustible material or toward anyone. To do so could cause**

**damage to the vehicle and serious personal injury to others.**

The High Exhaust System Temperature (HEST) lamp alerts the operator of high exhaust temperature during the regen process when the speed is below 5 mph (8 km/h), or during a manual regen. See [Fig. 3.1](#). The HEST lamp does not signify the need for any kind of vehicle or engine service; it only alerts the vehicle operator of high exhaust temperatures. Make sure the engine exhaust pipe outlet is not directed at any person, or at any surface or material that will melt, burn, or explode.

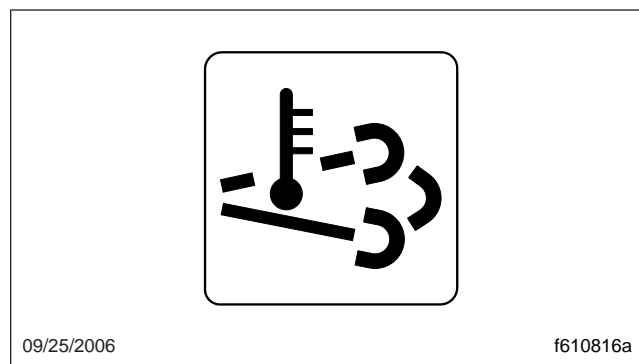

**Fig. 3.1, High Exhaust System Temperature (HEST) Lamp**

A solid yellow Diesel Particulate Filter (DPF) lamp indicates that a manual regen is required soon, and should be scheduled for the earliest convenient time. A blinking yellow DPF lamp indicates that a manual regen is required immediately, or an engine derate may occur. See [Fig. 3.2](#).

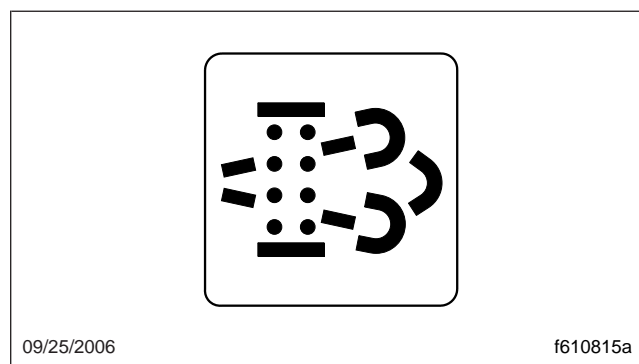

**Fig. 3.2, Diesel Particulate Filter (DPF) Status Lamp**

A solid yellow Malfunction Indicator Lamp (MIL) indicates an engine fault that affects the emissions. The

MIL lamp applies to the Mercedes-Benz engine only. See [Fig. 3.3](#).

Diesel particulate filter servicing must be performed by an authorized technician, and a record must be maintained for warranty purposes. The record must include:

- Date of cleaning or replacement
- Vehicle mileage
- Particulate filter part number and serial number

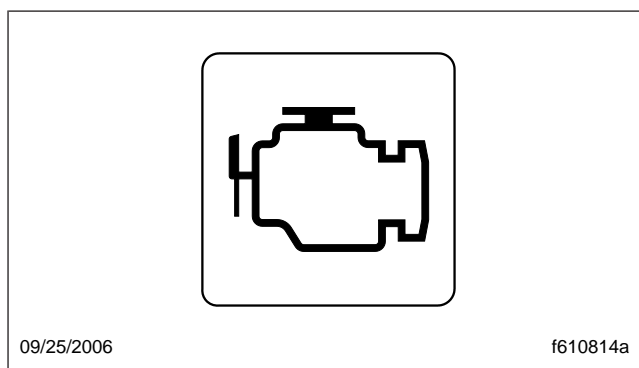

**Fig. 3.3, Malfunction Indicator Lamp (MIL)**

The DPF regen connector, located under the dash, may have two selectable positions:

- Request Regeneration
- Default (can include appropriate normal state condition—either in an automatic regeneration or inhibit state)

The function of the switch will vary by the engine make and model in the vehicle. See the engine operation manual for details.

## Engine Starting

### **⚠ WARNING**

**Do not use any starting aid, such as ether, in engines with an air intake heater. This could cause an explosion and serious personal injury or death.**

NOTE: For cold weather starting, see "Cold Weather Operation" in this chapter.

IMPORTANT: Before starting the engine, read [Chapter 2](#) in this manual for detailed informa-

tion on how to read the instruments and operate the controls. Also, before engine start-up, perform the engine pretrip inspection and daily maintenance checks in [Chapter 7](#).

### **⚠ CAUTION**

**If a vehicle does not start on the first attempt, make sure that the engine has completely stopped rotating before reapplying the starter switch. Failure to do so can cause the pinion to release and re-engage, which could cause ring gear and starter pinion damage.**

**Moving a vehicle with the starter and/or using the starter to bump the engine for maintenance procedures is strictly prohibited. Use of these methods to bump the engine over or move the vehicle can cause the pinion to release and re-engage, which could cause ring gear and starter pinion damage.**

IMPORTANT: Ring gear and starter pinion damage caused by improper starting procedures is not warrantable.

1. Set the parking brake.
2. Place the transmission in Neutral (N).

### **⚠ CAUTION**

**Do not crank the engine for more than 30 seconds at a time during any of the following procedures. Wait two minutes after each try to allow the starter to cool. Failure to do so could cause starter damage.**

## Caterpillar

NOTE: See the *Caterpillar Operation and Maintenance Manual* for detailed information on starting procedures.

## Cummins

### **⚠ CAUTION**

**If the engine is equipped with a turbocharger, protect the turbocharger during start-up by not opening the throttle or accelerating the engine**

# Engines

---

above 1000 rpm until normal engine idle oil pressure registers on the gauge.

NOTE: See the *Cummins Operation and Maintenance Manual* for detailed information on starting procedures.

## Mercedes-Benz

### CAUTION

Never attempt to start any Mercedes-Benz electronic engine using ether or any other starting fluid. Serious engine damage could result.

1. Turn the ignition switch to the START position. Without touching the accelerator pedal, start the engine.
2. Idle the engine for one to three minutes at 600 to 850 rpm before operating the engine under load.
3. Check the oil pressure gauge for any drop in lubricating oil pressure or mechanical malfunction in the lubricating oil system. Minimum oil pressure at idle is 7 psi (50 kPa).

### CAUTION

Do not rev the engine if the oil pressure gauge indicates no oil pressure. Shut down the engine if no oil pressure appears within approximately ten seconds. Check to determine the cause of the problem. Operating the engine with no oil pressure will damage the engine.

## Cold Weather Operation

### WARNING

Do not use any starting aid, such as ether, in engines with an air intake heater. This could cause an explosion and serious personal injury or death.

## Caterpillar

See the *Caterpillar Operation and Maintenance Manual* for cold weather procedures.

## Cummins

See the *Cummins Operation and Maintenance Manual* for cold weather procedures.

## Mercedes-Benz

See the *Mercedes-Benz Operation and Maintenance Manual* for cold weather procedures.

### CAUTION

Never attempt to start any Mercedes-Benz electronic engine using ether or any other starting fluid. Serious engine damage could result.

The intake air preheater is activated by turning the ignition switch to the ON position. If the engine is at normal temperature, the INTAKE HEATER indicator goes out after two seconds.

If the temperature is low enough to require the heater, the INTAKE HEATER indicator stays on while the intake air preheater warms up. After the indicator goes out, start the engine. If the engine doesn't start after about 30 seconds of cranking, turn the key to the OFF position and wait two minutes; then repeat the starting procedure.

NOTE: If the engine doesn't start on the second try, wait at least five minutes before using the intake air preheater again.

## Engine Operation

Operating vehicles with diesel engines in areas where there are concentrated flammable vapors (such as diesel, gasoline, or propane fumes) can create a hazardous situation. These vapors can be drawn into the engine through the air intake and cause engine overspeed. Be especially cautious of low-lying or closed-in areas, and always check for signs that flammable vapors may be present.

### DANGER

Do not operate the engine in an area where flammable vapors such as gasoline or diesel fumes are present. Shut down the engine when in an area where flammable liquids or gases are being handled. Failure to observe these precautions could result in serious injury or death.

NOTE: Heavy-duty engines are equipped from the manufacturer with ethylene glycol coolant only.

## Caterpillar

Caterpillar electronic engines can be equipped with a variety of options designed to warn the driver of engine malfunctions. The driver of a vehicle equipped with these engines should know the extent of the warning system in order to bring the vehicle to a safe stop if the engine malfunctions. If the driver doesn't understand how the warning system works, an engine shutdown could cause a safety hazard. See [Chapter 2](#) for information on the control panel for these engines.

The electronic control system can monitor engine oil pressure, coolant temperature, intake manifold air temperature, and coolant level.

In the engine monitoring "OFF" mode the ECM (electronic control module) will ignore the oil pressure sensor and coolant level sensor (if installed). Engine monitoring "WARNING" mode uses oil pressure, coolant temperature, intake manifold temperature, and the coolant level sensor (if so equipped and enabled). The "CHECK ENGINE" light will flash and the warning light will come on when the diagnostic code is active. Engine monitoring "DERATE" and "SHUT-DOWN" modes allow the ECM to alter engine performance or stop the engine to help the engine avoid damage and return to normal conditions.

**IMPORTANT:** Fuel heaters used on vehicles with Caterpillar electronic engines could cause excessive fuel temperature and affect engine performance and the operation of electronic engine controls. If a fuel heater is used, make sure that it has thermostatic controls. If the fuel heater has a timer, set the timer to activate only for a limited period of time before the engine starts. Make sure that the fuel heater is used only for starting the engine.

1. On a downhill grade, do not coast or put the transmission in Neutral (N). Select the correct gear that does not allow the engine to exceed its maximum speed. Use the brakes to limit vehicle speed.
2. As with any engine, prolonged idling of a Caterpillar engine is not recommended. An idling en-

gine wastes fuel and if left unattended is also unsafe.

## Cummins

The driver should be familiar with the vehicle warning system in order to bring the vehicle to a safe stop if the engine malfunctions. See [Chapter 2](#) for information on the control panel for these engines.

1. Cummins engines produce high horsepower and peak torque characteristics at low rpm. Because of this, it is not necessary to operate the engine at high rpm to deliver the required horsepower at the wheels. These characteristics may also result in less shifting and make shifting at lower rpm (to peak torque) more practical.
2. Depending on the vehicle gearing, the posted speed limit can sometimes allow operation in either of the top two gears; however, for improved operating efficiency (fuel economy and engine life), operate in the top gear at reduced rpm, rather than in the next lower gear at the maximum rpm.
3. Cruise at partial throttle whenever road conditions and speed requirements permit. This driving technique permits operating within the most economical power range of the engine.
4. When approaching a hill, open the throttle smoothly to start the upgrade at full power, then shift down as desired to maintain the optimum vehicle speed. The high torque of Cummins engines may permit topping some grades without shifting.
5. Cummins engines are designed to operate over a wide speed range. More frequent shifting than necessary does not allow proper utilization of this flexibility. The driver who stays in top gear and uses the wider speed range will achieve the best fuel economy.

---

### CAUTION

---

**Do not allow the engine to exceed its governed speed, or serious engine damage could result.**

6. The Cummins engine is effective as a brake on downhill grades, but take care not to overspeed the engine going downhill.

# Engines

7. Use a combination of brakes and gears to keep the vehicle under control at all times and to keep the engine speed below the rated governed rpm.

## Mercedes-Benz

NOTE: Mercedes-Benz engines are equipped with the electronic engine control system, which monitors the engine as it is running. If the engine control unit (ECU) detects a fault serious enough to harm normal operation, the electronic engine system switches over to emergency running mode. When in emergency running mode, the engine operates at a maximum 1300 rpm. This allows you to move the vehicle to a service location.

Proper operation and maintenance are key factors in obtaining the maximum life and economy of a vehicle engine. Follow the directions in this manual and the engine manufacturer's operator's manual for trouble-free, economical engine operation.

1. Depending on the vehicle gearing, the posted speed limit can sometimes allow operation in either of the top two gears; however, for improved operating efficiency (fuel economy and engine life), operate in the top gear at reduced rpm, rather than in the next lower gear at the maximum rpm.
2. Cruise at partial throttle whenever road conditions and speed requirements permit. This driving technique permits operating within the most economical power range of the engine.
3. Never allow the engine to exceed the high-idle governed speed (2700 rpm). Use the exhaust brake and the optional turbo or constant-throttle brake, if installed, to lower engine rpm below the high-idle governed speed.
4. Never allow the engine to idle for more than 30 minutes. Excessive idling can cause oil to leak from the turbocharger.

## Cruise Control

The cruise control allows you to automatically control the speed of the vehicle above 32 mph (50 km/h). The switches that operate the cruise control are located on the turn signal lever. See [Fig. 3.4](#).

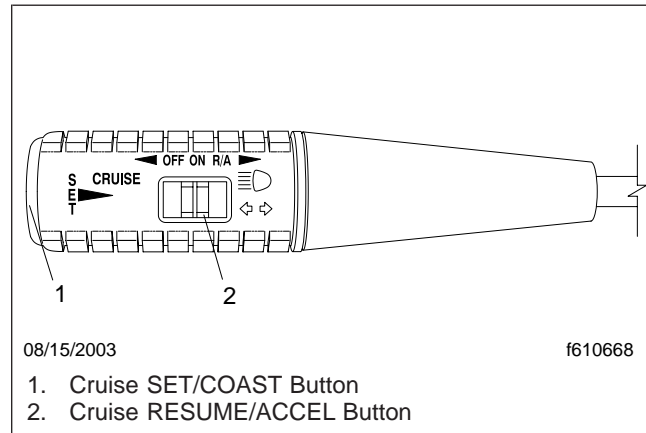

**Fig. 3.4, Cruise Control Switches (turn signal lever)**

NOTE: On vehicles equipped with the optional SmartWheel, the cruise control switches are located on the left switch panel. See [Fig. 3.5](#) and [Fig. 3.6](#).

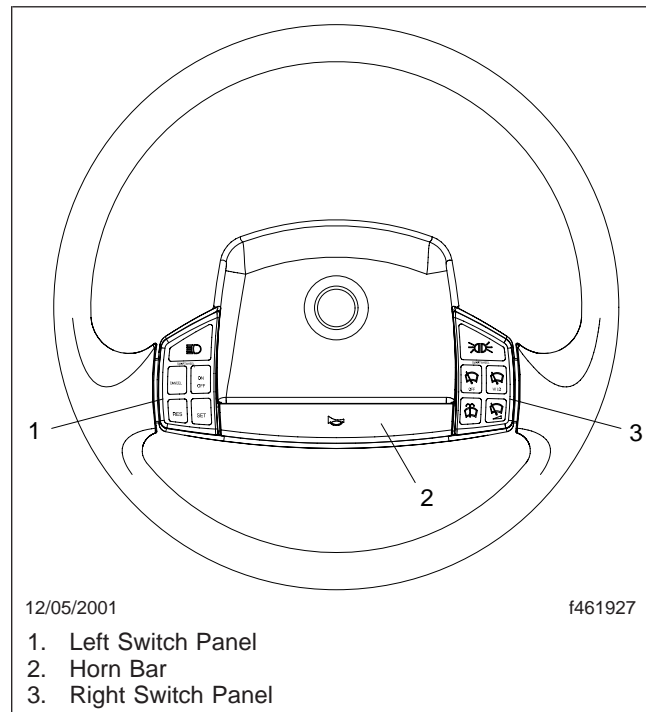

**Fig. 3.5, SmartWheel (optional)**



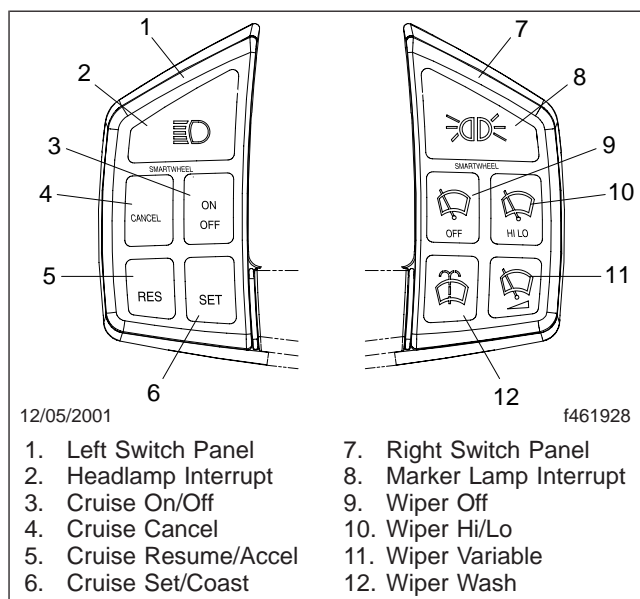

**Fig. 3.6, SmartWheel Switch Panels**

## ⚠ WARNING

**Do not use the cruise control system when driving conditions do not permit maintaining a constant speed, such as in heavy traffic or on roads that are winding, icy, snow covered, slippery, or roads with a loose driving surface. Failure to follow this precaution could cause a collision or loss of vehicle control, possibly resulting in personal injury or property damage.**

## ⚠ CAUTION

**Do not shift to Neutral (N) when using cruise control. This will cause the engine to overspeed, which can damage the engine.**

1. To cruise at a particular speed:
  - 1.1 Move the slide switch on the turn signal lever to the ON position or press the ON button on the steering wheel.
  - 1.2 Hold the accelerator pedal down until the vehicle reaches the desired speed. The speed must be above 32 mph (50 km/h).

- 1.3 Press and release the SET/COAST button at the end of the turn signal lever or press the SET/COAST button on the steering wheel.

- 1.4 One second after releasing the SET/COAST (lever) button or the SET/COAST on the steering wheel, take your foot off of the accelerator pedal.

You can increase the vehicle speed while the cruise control is engaged by pressing on the accelerator pedal, by moving the slide switch on the turn signal lever to the RESUME/ACCEL position, or by pressing the SET/COAST button on the steering wheel. When you release the pedal, the slide switch, or the button, the vehicle will return to the set speed.

To increase the set speed, accelerate to the desired speed, then press and release the SET/COAST (lever) button or the SET/COAST button on the steering wheel.

To decrease the set speed, press the SET/COAST (lever) button or the SET/COAST button on the steering wheel. When the vehicle slows to the desired speed, release the SET/COAST (lever) button or the SET/COAST button on the steering wheel.

2. To disengage the cruise control:
  - 2.1 Depress the brake pedal, *or*
  - 2.2 Move the slide switch on the turn signal lever to the OFF position or press the OFF button on the steering wheel.

If the brake pedal was used to disengage the cruise control, you can return the vehicle to the set speed with the slide switch or the steering wheel button. Accelerate to a speed above 32 mph (50 km/h), then move the slide switch to the RESUME/ACCEL position or press the RESUME/ACCEL button on the steering wheel. The cruise control will return the vehicle to the set speed.

**NOTE:** The set speed will be maintained within 4 mph (6 km/h) above or below the set speed when grades do not exceed 7-percent (most

# Engines

---

interstate highways). At higher altitudes, the set speed can vary by more than 4 mph (6 km/h).

If actual vehicle speed decreases 5 mph (8 km/h) or more below the set speed, the cruise control will automatically disengage.

When pulling a heavy load, climbing a very steep hill, or driving into a strong wind, bring the vehicle up to speed with the accelerator pedal and then let the cruise control take over.

3. High Idle (With Cruise Control Option)
  - 3.1 Place the shift lever in Neutral (N).
  - 3.2 On the turn signal lever, move the slide switch to the ON position or press the ON button on the steering wheel. Accelerate to the desired rpm. Press and release the SET/COAST or SET/COAST button on the steering wheel.
  - 3.3 Disengage by stepping on the brake pedal, by moving the ON/OFF switch to the OFF position, or by pressing the OFF button on the steering wheel.

## SmartWheel Cruise Control

 **WARNING**

**Do not use the cruise control system when driving conditions do not permit maintaining a constant speed, such as in heavy traffic or on roads that are winding, icy, snow covered, slippery, or roads with a loose driving surface. Failure to follow this precaution could cause a collision or loss of vehicle control, possibly resulting in personal injury or property damage.**

### Cruise On/Off

Press the cruise control ON/OFF switch to activate the cruise control or to turn it off.

### Cruise Set

Press the cruise control SET/COAST switch to set the desired cruising speed.

### Cruise Accel

Press the cruise control RESUME/ACCEL switch to accel above the current speed setting.

### Cruise Resume

Press the cruise control RESUME/ACCEL switch to resume cruise control activation.

### Cruise Coast

Press the cruise control SET/COAST switch to coast the vehicle.

### Cruise Cancel

Press the cruise control CANCEL switch to disengage cruise control without losing the current speed setting.

## Engine Shutdown

 **CAUTION**

**Stopping the engine immediately after it has been working under load can result in overheating and accelerated wear of engine and turbocharger components and cause oil coking problems. Follow the procedures outlined below to allow the engine to cool.**

**When safe to do, shut down the engine at the first sign of malfunction. Almost all malfunctions give some warning to the operator before significant damage occurs. Many engines are saved because alert operators heed warning signs (sudden drop in oil pressure, unusual noises, etc.) and immediately shut down the engine.**

### Caterpillar

1. With the vehicle stopped, apply the parking brakes. Reduce the engine speed to low idle.
2. Place the transmission in Neutral (N).
3. If the engine has been operating at low loads, run it at low idle for 30 seconds before stopping. If the engine has been operating at highway speed or at high loads, run it at low idle for three minutes to reduce and stabilize internal engine temperatures before stopping.
4. Turn the ignition key to the OFF position to shut down the engine.
5. If the engine is equipped with an idle shutdown timer, it can be set to shut the engine down after a preset amount of time. Ninety seconds before



the preset shutdown time, the "CHECK ENGINE" light will begin to flash at a rapid rate. If the clutch pedal or service brake indicates a position change during this final 90 seconds, (with the diagnostic lamp flashing) the idle shutdown timer will be disabled until reset.

6. After stopping the engine, fill the fuel tank.
7. Check the crankcase oil level while the engine is stopped. Maintain the oil level between the ADD and FULL marks on the dipstick.
8. If freezing temperatures are expected, allow the engine water jacket expansion tank to cool. Then check the coolant for proper antifreeze protection. The cooling system must be protected against freezing to the lowest expected outside temperature. Add permanent-type antifreeze, if required.
9. Repair any leaks, perform minor adjustments, tighten loose bolts, etc. Observe the vehicle mileage or the service meter reading, if so equipped.

## Cummins

1. With the vehicle stopped, place the transmission shift lever in the Neutral (N) position and set the parking brake using the parking brake control knob.
2. It is important to idle an engine for 3 to 5 minutes before shutting it down. This allows the lubricating oil and the water to carry heat away from the combustion chambers, bearings, shafts, etc. This is especially important with turbocharged engines.
3. Do not idle the engine for excessively long periods.

**IMPORTANT:** Long periods of idling are not good for an engine because the combustion chamber temperatures drop so low that the fuel may not burn completely. This will cause carbon to clog the piston rings and may result in stuck valves.

4. If the engine is not being used, shut it down by turning the ignition key to the OFF position.

## Mercedes-Benz

### Emergency Shutdown

If any of the following occur, shut down the engine immediately:

- the oil pressure swings back and forth or falls sharply
- engine power and rpm fall even though the accelerator pedal remains steady
- the engine gives off heavy exhaust smoke
- the coolant and/or oil temperature climb abnormally
- abnormal sounds suddenly occur in the engine or turbocharger

### Normal Engine Shutdown

1. With the vehicle stopped, apply the parking brake and place the transmission in neutral.

### CAUTION

**Idle the engine one to two minutes before shutting it down, if this can be done without damage to the engine. After hard operation, shutting down the engine without idling may cause damage to the turbocharger.**

2. Allow the engine to idle one to two minutes before shutting it down. This allows the lubricating oil and the coolant to carry heat away from the combustion chambers, bearings, shafts, and seals. The extreme heat may cause bearings to seize or oil seals to leak.

**IMPORTANT:** Bearings and seals in the turbocharger are subjected to the high heat of combustion exhaust gases. While the engine is running, this heat is carried away by oil circulation, but if the engine is stopped suddenly, the turbocharger temperature may rise as much as 115°F (46°C).

### CAUTION

**Except in emergency, do not shut down the engine when the coolant temperature is above 194°F (90°C). To do so could damage the engine.**

# Engines

---

3. Turn off the ignition switch and shut down the engine.

## High Altitude Operation

Engines lose horsepower when operated at high altitude because the air is too thin to burn as much fuel as at sea level. Most turbocharged engines are rated for higher altitudes than naturally aspirated engines. An engine will have smoky exhaust at high altitudes unless a lower gear is used. Shift gears as needed to avoid excessive exhaust smoke.

## Engine Braking (optional)

### Exhaust Brake

**IMPORTANT:** The exhaust brake is a vehicle slowing device, not a vehicle stopping device. It is not a substitute for the vehicle service brakes. Use of the exhaust brake for vehicle downhill control and slowing down on level terrain will allow the service brakes to remain cool and ready for an emergency.

 **WARNING**

**Do not use the exhaust brake if road surfaces are slippery. Using the exhaust brake on wet, icy, or snow-covered roads could result in loss of vehicle control, possibly causing personal injury or death, or property damage.**

To get the best result from the exhaust brake, it is necessary to observe several simple operating principles.

The exhaust brake is activated when the following conditions are satisfied.

1. The ON/OFF switch is in the ON position.
2. The engine is not being fueled.

The Allison transmission provides for optimum retarding downshift operation when the exhaust brake is selected. When the switch is turned ON and your foot is removed from the throttle pedal, the transmission will immediately preselect a lower gear. The transmission then starts to downshift through the gears to reach the preselected gear. Downshifting occurs at a higher speed than is usual when the exhaust brake is

not turned on. This allows the exhaust brake to provide the maximum retarding power.

## Compression (Engine) Brake (VCL only)

**IMPORTANT:** A compression (engine) brake is a hydraulic-electric engine attachment that converts a diesel engine into an air compressor. This is done by changing engine exhaust valve operation. A compression (engine) brake is not a substitute for a service braking system, except in emergencies, because it does not provide the precise control available from the service brakes.

 **WARNING**

**Do not use the compression brake if road surfaces are slippery. Using the compression brake on wet, icy, or snow-covered roads could result in loss of vehicle control, possibly causing personal injury or death, or property damage.**

The compression brake is controlled by a single switch with three positions: OFF, LO, and HI.

To engage the compression brake, the switch must be in the LO or HI position and the throttle pedal must be fully released. To disengage the compression brake, depress the throttle pedal, or move the dash switch to OFF.

 **WARNING**

**If the compression brake is engaged when the transmission is in Neutral (N), the braking power of the compression brake can stall the engine, which could result in loss of vehicle control, possibly causing personal injury or death, or property damage.**

Since the compression brake is most effective at rated engine speed, gear selection is very important. Gearing down the vehicle within the limits of the rated engine speed makes the compression brake more effective. Maximum braking occurs with the use of the lowest gear that does not exceed the rated engine speed. A rule of thumb for gear choice is to select the gear that normally would be used to climb an approaching downhill grade. Generally, this same

gear can be used with the compression brake for a controlled descent of the hill.

"Control speed" is the speed at which the compression brake performs 100 percent of the required downhill braking, resulting in a constant speed of descent. The control speed varies, depending on vehicle weight and the downhill grade.

For faster descent, select a higher gear than that used for control speed. Service brakes must then be used intermittently to prevent engine overspeed and to maintain desired vehicle speed.

**IMPORTANT:** When descending a grade, remember that frequent use of service brakes causes them to become hot, which results in a reduction of their stopping ability. Control grade descent speed so that the service brakes are used infrequently and remain cool, thus retaining their effectiveness.

A driver may descend at a rate slower than control speed by selecting a lower gear, one that will not overspeed the engine. The compression brake retarding force will then be sufficient to cause vehicle deceleration. Occasional deactivation of the compression brake may be necessary to maintain the designated road speed under these conditions.

The compression brake can be used to assist in stopping a vehicle if the service brakes quit working. By energizing the compression brake as soon as a service brake problem is apparent, a retarding effect is applied to the vehicle. As grade conditions permit, the driver can progressively downshift, using the compression brake in each gear. Eventually, the compression brake will stop the vehicle.

## **WARNING**

**Using the compression brake as a primary braking system when the service brakes are operable is dangerous. This can cause long, unpredictable stopping distances, possibly resulting in personal injury or death, or property damage.**

Whenever vehicle braking is required, the compression brake may be used with the service brakes. There is no time limit for operation of the compression brake.

1. After the engine is warmed up and the vehicle is in motion, move the switch to the desired position, LO or HI. Depending on the engine model,

LO will provide 1/3 to 1/2 of the full braking capacity of the engine. HI will provide maximum engine braking.

2. The compression brake activates when the switch is in either the LO or the HI position and the driver's foot is removed from the throttle pedal. If it fails to activate, stop the vehicle in a safe spot and check the adjustment of the throttle switch. If no cause can be detected in the electrical system, check the compression braking system.
3. To obtain the maximum retarding effect, maintain the top governed speed of the engine through the appropriate selection of gears when the compression brake is in use.
4. When the throttle pedal is depressed, the compression brake is deactivated.

## **CAUTION**

**If the compression brake fails to shut off when the switch is turned off, shut down the engine and repair the compression brake before continuing operation. Failure to do so could result in damage to the engine.**

## Mercedes-Benz

### Constant-Throttle Valves

To increase braking performance, Mercedes-Benz engines are equipped with constant-throttle valves (optional) in each combustion chamber. Small valves built into the cylinder head allow a small amount of compressed air to escape through the exhaust port during the combustion stroke. The constant-throttle valves are open during the entire time that the engine brake is activated. Although some braking ability is lost because the valves are constantly open, constant-throttle braking is quieter in operation than other types of engine brakes.

When both the exhaust brake and the constant throttles are installed, a three-position switch on the dash controls the amount of engine braking delivered. Like the exhaust brake, the constant throttles are deactivated when the accelerator or clutch pedal is depressed. The ABS system, when active, also deactivates constant-throttle braking.

# Engines

---

The engine brake will deactivate if the engine speed falls below a preset level. This level is programmable but is set at the factory at 1100 rpm.

## Exhaust Brake

An exhaust brake is an optional auxiliary braking system that assists but does not replace the service brake system. The exhaust brake can be used alone or together with the constant-throttle valves for steep or long grades. The exhaust brake switch located on the control panel, in combination with the accelerator and clutch pedals, allows the driver to make maximum use of the exhaust brake in off-highway and mountain driving as well as in traffic or high speed highway driving.

The exhaust brake is only active when the engine speed is between 1100 and 2700 rpm. Depressing the accelerator or clutch pedal deactivates the exhaust brake. The ABS system, when active, also deactivates the exhaust brake.

The exhaust brake is a butterfly valve mounted in the exhaust pipe. When the driver's foot is not on the accelerator pedal and the upper half of the exhaust brake switch is pressed in, with the amber light on the switch illuminated, an air cylinder shuts the butterfly valve which restricts the flow of exhaust gases and retards the engine. This retarding action is carried through the engine and drivetrain, slowing the vehicle and reducing the need for frequent service brake applications.

Exhaust brakes are not intended for use as the primary braking system during vehicle operation.

# 4

## Transmissions

---

Allison Automatic Transmissions .....	4.1
---------------------------------------	-----

# Transmissions

## Allison Automatic Transmissions

### CAUTION

Do not allow the vehicle to coast in neutral. This can result in severe transmission damage. Also, no engine braking is available.

### WARNING

Never shift from neutral (N) to drive (D) or reverse (R) at engine speeds above idle. The vehicle will lurch forward or backward, which could cause property damage and personal injury.

### CAUTION

The engine should never be operated for more than 30 seconds at full throttle with the transmission in gear and the output stalled. Prolonged operation of this type will overheat the transmission fluid and will result in severe damage to the transmission.

## 1000/2000/2000 MH Models

### Operation

**IMPORTANT:** The Allison 2000 MH 5-speed transmission requires the use of TranSynd Synthetic ATF (automatic transmission fluid). Do *not* use Dexron III ATF in this transmission.

1. Select Drive (D) for all normal driving conditions. See [Fig. 4.1](#). The vehicle will start out in First (1) gear, and as speed increases, the transmission will upshift through each gear automatically. As the vehicle slows down, the transmission will downshift to the correct gear automatically.

Occasionally the road, load, or traffic conditions make it desirable to restrict the automatic shifting to a lower range. The lower the gear range, the greater the engine braking power.

2. Use Second (2) for slow driving in heavy city traffic, or on mountain roads when more precise speed control is desirable. Use it also for climbing long grades and for engine braking when descending moderately steep grades. To prevent

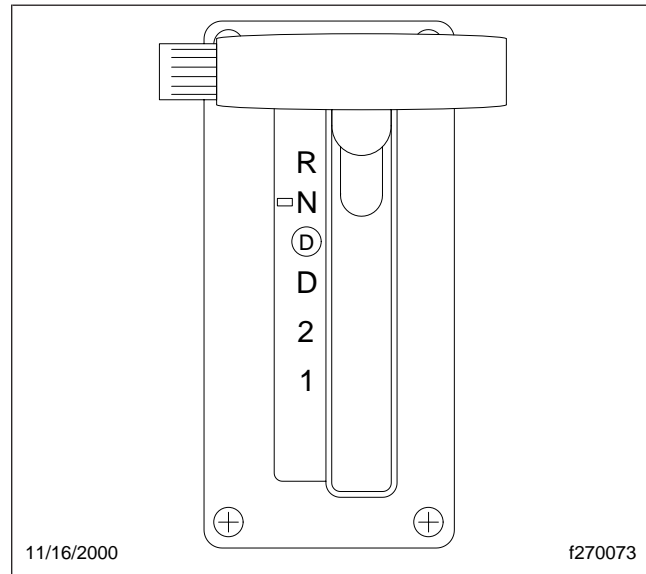

**Fig. 4.1, 1000, 2000, 2000 MH Shift Selector Lever (typical)**

excessive engine speed, do not drive faster than 45 miles per hour (72 km/h) in this range.

3. Use First (1) for climbing very steep grades and for engine braking at low speeds when going downhill. To prevent excessive engine speed, do not drive faster than 25 miles per hour (40 km/h) in this range.

**NOTE:** In the lower gear ranges, the transmission will not upshift above the highest gear selected unless the engine governed speed is exceeded.

See the *Allison Transmission Operator's Manual* for more information on 1000, 2000, and 2000 MH transmission operation.

## 3000 MH/4000 MH/4000 MHP Models

### General Information

3000 MH, 4000 MH, and 4000 MHP series automatic transmissions have six forward speeds and one Reverse (R) speed. These transmissions have electronic shift controls that can be programmed to allow the use of different numbers of geared speeds. See [Fig. 4.2](#). For instance the transmission can be programmed to operate as a 4-speed, 5-speed, or 6-speed unit in the "primary" shift mode. If needed, a



"secondary" shift mode can be programmed to provide another shift configuration to optimize vehicle use under different operating conditions. To activate a secondary shift mode, or other special function programmed into the electronic control unit (ECU), depress the Mode button. A label just above the Mode button identifies the special function.

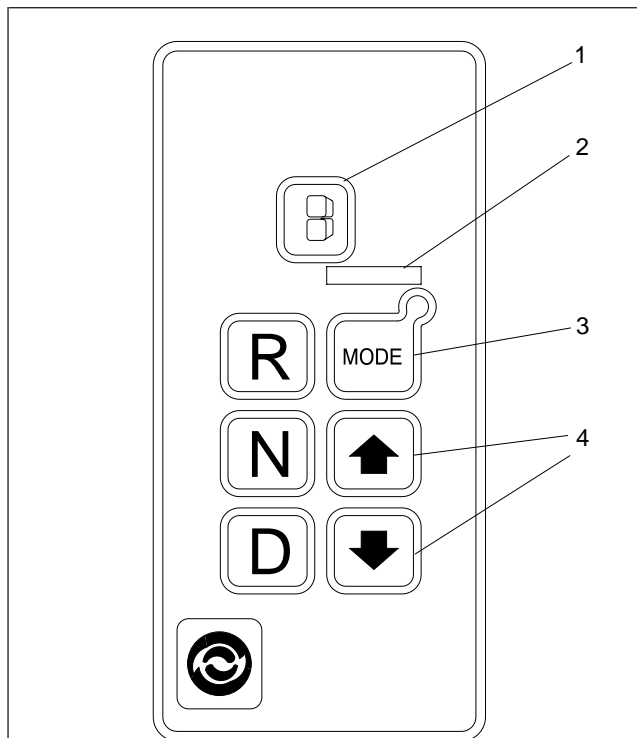

11/16/2000

t270113a

NOTE: The number displayed on the Digital Display button is the highest forward range available in the selected position. Visually check to confirm the range selected. If the display is flashing, the shift is inhibited.

1. Digital Display
2. Mode ID
3. Mode Indicator (LED)
4. Push Simultaneously for Diagnostic Mode and Fluid Level Check (optional)

**Fig. 4.2, WTEC III Shift Selector**

The 3000 MH, 4000 MH, and 4000 MHP series transmission systems are designed to warn the driver of transmission malfunctions. The driver of a vehicle equipped with these transmissions should know the extent of the warning system in

order to safely operate the vehicle. See **Chapter 2** for information on the warning system.

## Operation

1. Start the engine.
2. Use Reverse (R) to back the vehicle. Completely stop the vehicle before shifting from a forward gear to Reverse (R) or from Reverse (R) to a forward gear. There is only one Reverse (R) gear.
3. Select Drive (D) for all normal driving conditions. The vehicle will start out in First (1) gear, and as speed increases, the transmission will upshift through each gear automatically. As the vehicle slows down, the transmission will downshift to the correct gear automatically.

The pressure of your foot on the accelerator pedal influences the automatic shifting. When the pedal is fully depressed, the transmission will automatically upshift near the governed speed of the engine. A partially depressed position of the pedal will cause the upshifts to occur at a lower engine speed.

4. Occasionally the road, load, or traffic conditions make it desirable to restrict the automatic shifting to a lower range. The lower the gear range, the greater the engine braking power.

Use the up or down arrow buttons on the shift selector to reach the desired gear.

5. Use Neutral (N) and apply the parking brake when the vehicle is parked with the engine running.

See the *Allison Transmission Owner's Manual* for more information on 3000 MH and 4000 MH transmission operation.

NOTE: In the lower gear ranges, the transmission will not upshift above the highest gear selected unless the engine governed speed is exceeded.

## 1000/2000/2100/2400 Models (Arens SBW)

### General Information

The Arens shift-by-wire (SBW) push-button shift selector is part of an electronic shift control system

# Transmissions

used with Allison series 1000/2000/2100/2400 5-speed automatic transmissions. An electronic actuator is mounted to the transmission.

The 1000/2400 series transmissions have a park pawl and the SBW selector has a Park (P) position. The 2000 and 2100 series transmissions do not have a park pawl and there is no Park (P) position button on the selector. The 2100 series transmission has a park brake (Pb) button. Otherwise, the two selectors are identical. See [Fig. 4.3](#), [Fig. 4.4](#), and [Fig. 4.5](#).

In case the vehicle needs to be towed and the SBW system cannot be activated to move the transmission out of Park (P), a manual procedure is provided to shift the transmission. At the actuator, on the transmission, a port is provided to insert an Allen wrench to shift the transmission manually. See [Chapter 10](#) for more information.

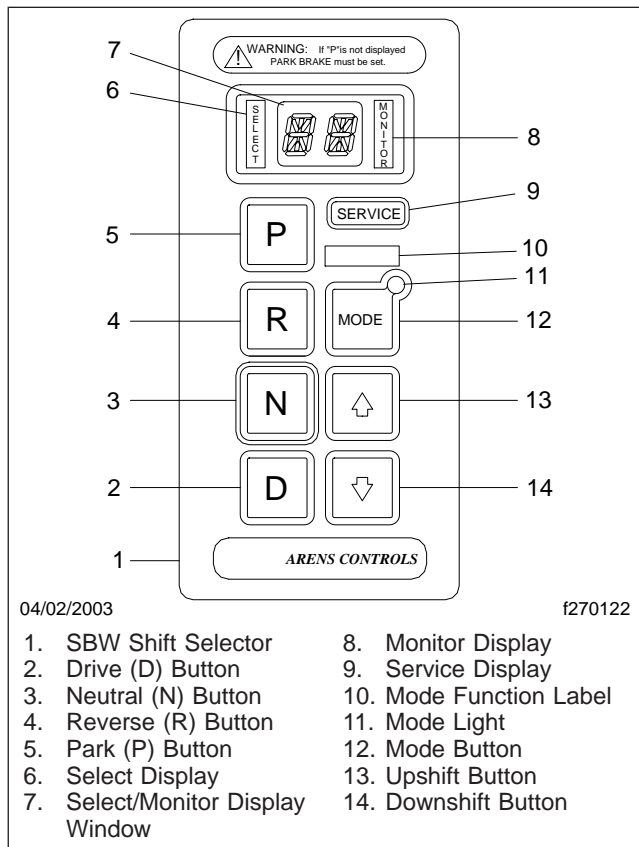

**Fig. 4.3, SBW Shift Selector (1000/2400 series)**

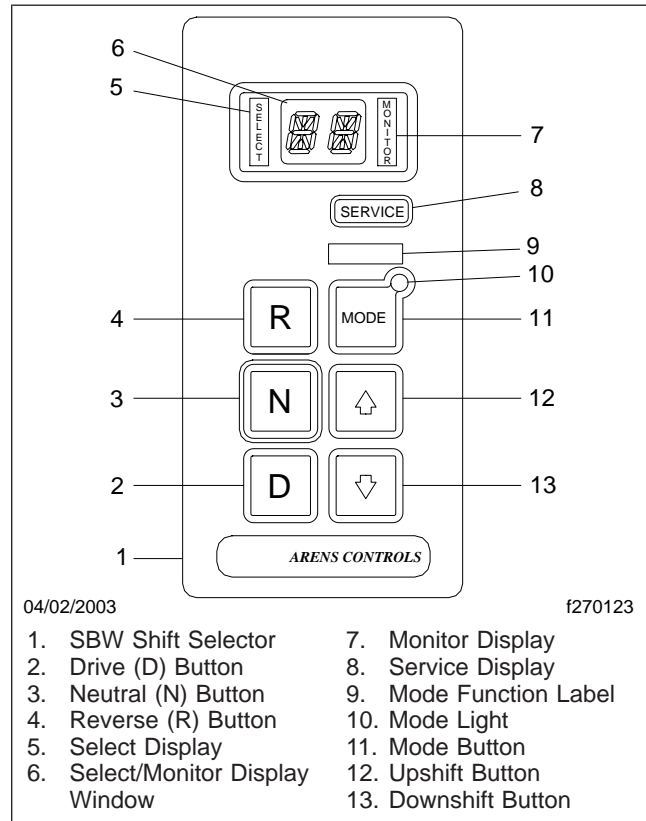

**Fig. 4.4, SBW Shift Selector (2000 series)**

## Transmission Operation

1. At the top left side of the selector, is the select display. On the left side of the display window, an LED character indicates which gear has been selected.
2. At the top right side of the selector, is the monitor display. On the right side of the display window, an LED character indicates which gear is actually engaged.



**If the Park (P) position is selected and the letter P does not appear on the monitor side of the display window, you must set the parking brake. Otherwise the vehicle could move unexpectedly and cause an accident, possibly resulting in personal injury and property damage.**



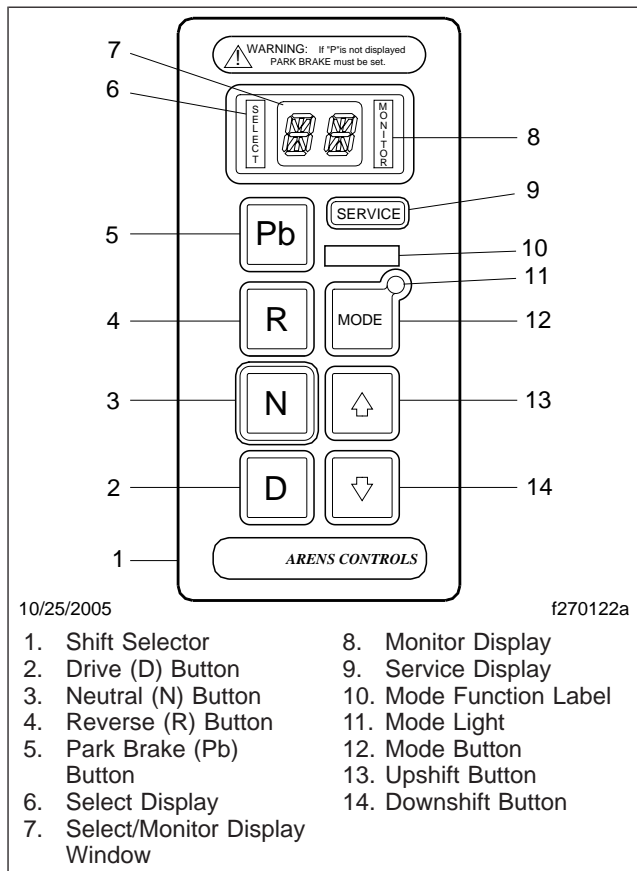

**Fig. 4.5, SBW Push-Button Shift Selector with Park Brake (Pb) Button (2100 Series, front-engine diesel chassis)**

NOTE: Only the 1000/2400 series 5-speed transmissions have a park pawl and a Park (P) button.

3. The Park (P) button shifts the transmission to Neutral (N) and engages the park pawl. When Park (P) is selected, the monitor side of the display window will show a letter P.

## WARNING

**Always place the transmission in the Park (P) or Neutral (N) position and set the parking brake before releasing the service brakes and exiting the vehicle. Otherwise the vehicle could move unexpectedly and cause an accident, possibly resulting in personal injury and property damage.**

## CAUTION

If the ignition switch is turned to the OFF position before selecting Park (P), a buzzer will sound and the monitor display will show the gear that is currently engaged. Select Park (P) to turn off the buzzer and the display. Also, with the engine not running (ignition switch in the ON position and park pawl not engaged), a buzzer will sound and the monitor display will show an N for Neutral (N). Select Park (P) to turn off the buzzer and the display.

4. Select the R button to place the transmission in Reverse (R). An R will appear on both sides of the display window.

## WARNING

**Do not leave the vehicle if the transmission is in Neutral (N) without first setting the parking brake. The vehicle could roll or move unexpectedly and cause an accident, possibly resulting in personal injury and property damage.**

5. Select the N button to place the transmission in Neutral (N). An N will appear on both sides of the display window. The vehicle may be started in Neutral (N).
6. Select the D button to place the transmission in Drive (D). The transmission will automatically shift through the full range of First (1) through Fifth (5) gears. When Drive (D) is first selected, the display will show D1, indicating that Drive (D) was selected and that First (1) gear is engaged. As the transmission automatically upshifts and downshifts, the display will show the gear currently engaged (D1, D2, D3, D4, or D5).
7. With the transmission in Drive (D), select the downshift (down arrow) button to manually downshift one gear at a time, from Fifth (5) to First (1). The select display will show the selected gear and the monitor display will show the gear currently engaged. From D5 at the top of the Drive (D) range, the display will show 44, 33, 22, and 11 as progressively lower gears are manually selected.

NOTE: The transmission will remain in the manually selected gear until Drive (D) is selected. Select Drive (D) at any time during the

# Transmissions

---

manual downshifting sequence (or upshift progressively to Drive [D] using the up arrow button) and the transmission will upshift and downshift automatically.

8. With the transmission in 11, 22, 33, or 44, select the upshift (up arrow) button to manually upshift one gear at a time until Drive (D) is selected. The select display will show the selected gear and the monitor display will show the gear currently engaged. From 11 at the bottom of the Drive (D) range, the display will show 22, 33, 44, and D5 as progressively higher gears are manually selected.

**NOTE:** The transmission will remain in the manually selected gear until Drive (D) is selected. Select Drive (D) at any time during the manual upshifting sequence and the transmission will upshift and downshift automatically.

9. The function of the mode button may vary from vehicle to vehicle. The label above the button identifies the function.
10. A light in the upper right-hand corner of the mode button illuminates when the mode function is active.



## CAUTION

**An illuminated service display may indicate a loss of safety back-up systems. Use extra care when shifting to ensure that the transmission is operating properly.**

11. The service display illuminates if a fault is detected in the SBW system. Have a qualified technician inspect the SBW system as soon as possible.
12. A flashing select/monitor display indicates that the transmission (and not the SBW system) has inhibited a selected transmission operation. See the *Allison Transmission Operator's Manual* for more information.

# 5

## Steering System

---

Power Steering System .....	5.1
Tilt/Telescope Steering Column .....	5.1

# Steering System

## Power Steering System

NOTE: When there is no load on the vehicle and the front tires are pointed straight ahead, the steering wheel spokes should be at the 9 and 3 o'clock positions or within 10 degrees to either side. See [Fig. 5.1](#).

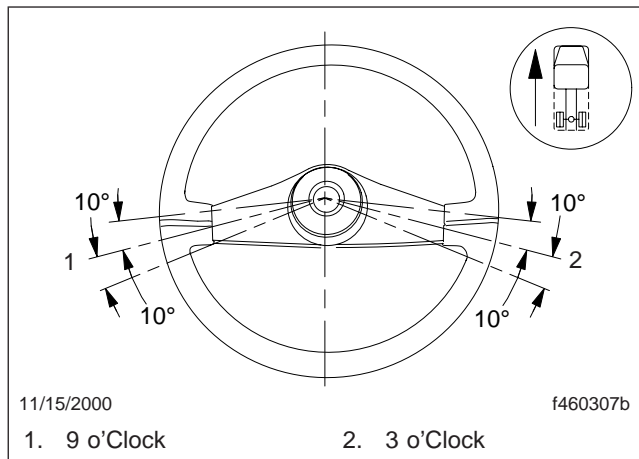

Fig. 5.1, Steering Wheel Centered

## Tilt/Telescope Steering Column



Never try to tilt or telescope the steering column while driving the vehicle. Doing so could cause loss of vehicle control and result in personal injury or death, or property damage.

### Douglas Column

To change the position of your steering wheel, pull the tilt/telescope lever upward and move the steering wheel to the desired position. Release the lever to lock the position. The steering wheel can also be tilted up to provide easier exit and reentry. See [Fig. 5.2](#).

If the vehicle is equipped with a telescoping steering column, push the lever downward and extend or retract the steering wheel as desired.

### TRW Column

To tilt the steering column, press down on the foot pedal (located below the steering wheel) to release the steering column lock. Adjust the column to the

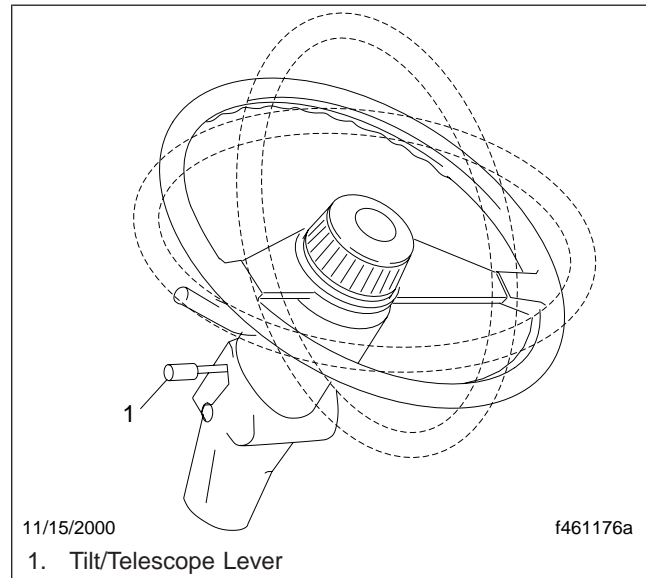

Fig. 5.2, Douglas Tilt/Telescope Steering Column (typical)

desired position. Release the foot pedal to lock the steering column in place. To telescope the steering column, press down on the foot pedal to release the steering column lock. Pull the steering wheel upward or push it downward until it is at the desired height. Release the foot pedal to lock the steering column in place.

NOTE: For safety, the steering column is locked at all times unless the foot pedal is depressed.

# 6

## Brake System

---

Air Brake System .....	6.1
Antilock Braking System (ABS) .....	6.3
Hydraulic Brake System (front-engine diesel chassis) .....	6.4

# Brake System

---

## Air Brake System

### General Information

#### **WARNING**

Freightliner neither recommends nor approves connecting a trailer or other towed vehicle's braking system directly to the vehicle braking system. Freightliner also neither recommends nor approves tapping into the vehicle air brake system nor operating a towed vehicle or trailer's braking system by means of the vehicle braking system. Failure to observe this warning could result in personal injury or death, or substantial property damage.

A dual air brake system consists of two independent air brake systems which use a single set of brake controls. Each system has its own reservoir, plumbing, and brake chambers. The primary system operates the service brakes on the rear axle; the secondary system operates the service brakes on the front axle.

#### **WARNING**

**Do not operate the vehicle with the front brakes backed off or disconnected. Backing off or disconnecting the front brakes will not improve vehicle handling and may lead to loss of vehicle control resulting in property damage or personal injury.**

Before driving your vehicle, allow time for the air compressor to build up a minimum of 95 psi (655 kPa) pressure in both the primary and the secondary systems. Monitor the air pressure system by observing the dual system air pressure gauges and the low-air-pressure warning light and buzzer. The warning light and buzzer shut off when the pressure in both systems reaches 65 to 73 psi (448 to 503 kPa).

The warning light and buzzer come on if air pressure drops below 65 to 73 psi (448 to 503 kPa) in either system. If this happens, check the air system pressure gauges to determine which system has low air pressure. Although the vehicle's speed can be reduced using the foot brake control pedal, either the front or the rear service brakes will not be operating, causing a longer stopping distance. Bring the vehicle to a safe stop and have the air system repaired before continuing.

The parking brake will apply when air pressure drops below 38 to 42 psi (262 to 290 kPa). Do not wait for the brake to apply automatically; when the warning light and buzzer first come on, immediately bring the vehicle to a safe stop. Before continuing operation of the vehicle, correct the cause of the air loss.

#### **Air Brake System With External Fill (Schrader) Valve**

If your engine will not start and it is desirable to release the parking brake, do the following: Block the wheels. Turn the ignition switch to the ON position. Fill the air reservoir for the braking system by external means. The parking brake will not release until air pressure reaches 65 psi (448 kPa). The low air buzzer will sound until air pressure reaches 65 to 73 psi (448 to 503 kPa) with the ignition switch in the ON position.

#### **CAUTION**

**If the air pressure in the braking system drops back below 38 to 42 psi (262 to 290 kPa) the parking brake will reengage.**

### Operation

Before driving the vehicle, secure all loose items in the cab so that they will not fly forward during a full brake application. Make sure that all occupants are wearing seat belts.

During normal brake stops, depress the foot brake control pedal until braking action slows the vehicle. Increase or decrease the pressure on the pedal so that the vehicle comes to a smooth, safe stop. When the forward speed of the vehicle has decreased almost to the idling speed of the engine, shift the transmission into Neutral (N). Apply the parking brake if the vehicle is to be parked.

**IMPORTANT:** In the event of a total loss of service brakes with full system air pressure, use the parking brake control valve (yellow knob) to bring the vehicle to a complete stop in the safest location possible.

The yellow diamond-shaped knob on the control panel actuates the parking brake valve. See [Fig. 6.1](#). Pull out the knob to apply the parking brake.

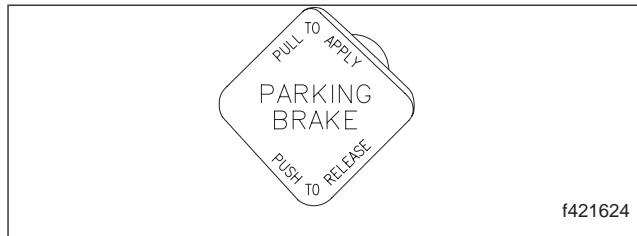

Fig. 6.1, Parking Brake Control Knob

## WARNING

If the vehicle is equipped with an air suspension system, do not move the vehicle with the air suspension deflated. Doing so could result in a loss of vehicle control, possibly causing personal injury and property damage.

## CAUTION

Do not use the spring parking brakes if the service brakes are hot, such as after descending a steep grade. Also, do not use the spring parking brakes during freezing temperatures if the service brakes are wet. To do so could damage the brakes if hot, or cause them to freeze during cold weather.

If the brakes are wet, drive the vehicle in low gear and lightly apply the brakes to heat and dry them. Allow hot brakes to cool before using the spring parking brakes. Always chock the tires.

If the brakes are wet, drive the vehicle in Low (L) or First (1) gear and lightly apply the brakes to heat and dry them.

Allow hot brakes to cool before using the parking brake. Always chock the tires.

## Brake Burnishing (new vehicle)

### CAUTION

Check the brake system and ensure that it is in proper operating condition before attempting the brake burnishing procedure.

1. In a safe area, make 10 sharp brake applications or "snubs," slowing the vehicle from 40 to 20 mph (64 to 32 km/h) using light (approximately 10 to 20 psi [69 to 138 kPa]) brake pressure.

2. Make 10 stops from 20 mph (32 km/h) using moderate (20 to 30 psi [138 to 207 kPa]) brake pressure.
3. Make 2 stops from 20 mph (32 km/h) using hard (full application of air pressure) brake applications.

NOTE: After the hard brake applications, it is normal to notice a hot brake odor.

4. Next, drive the vehicle approximately 5 to 7 miles (8 to 11 km) allowing the brakes to cool, and then come to a stop.

NOTE: After performing the burnishing procedure, there should be no brake noise and the brakes should have good stopping ability.

5. Inspect each wheel and ensure that there is no excessive end-play.
6. Inspect the brake adjusters and air chambers and ensure that the pushrods have proper and equal stroke.
7. If the brakes pull the vehicle to one side or grab after the burnishing procedure, contact a Freightliner RV dealer for service.

## Automatic Slack Adjusters

Automatic slack adjusters are required on all vehicles equipped with air brakes manufactured after October 20, 1994. Automatic slack adjusters should never be manually adjusted except during routine maintenance of the foundation brakes (e.g., replacing shoes), during slack adjuster installation or in an emergency situation.

When the brake pushrod stroke exceeds the legal brake adjustment limit on a vehicle, there is likely a mechanical problem with the foundation brake components or the adjuster is improperly installed.

Visit a repair facility as soon as possible when brakes equipped with automatic slack adjusters are determined to be out of adjustment.

## WARNING

**Manually adjusting an automatic slack adjuster to bring the pushrod stroke within legal limits is likely masking a mechanical problem. Adjustment is not repairing. In fact, continual adjustment of**



# Brake System

---

automatic slack adjusters may result in premature wear of the adjuster itself. Further, the improper adjustment of some automatic slack adjusters may cause internal damage to the adjuster, thereby preventing it from properly functioning.

## Antilock Braking System (ABS)

### Meritor WABCO® Antilock Braking System (ABS)

The Meritor WABCO Antilock Braking System (ABS) is an electronic wheel speed monitoring and control system that works with the air brake system. ABS passively monitors vehicle wheel speed at all times, but *controls* wheel speed during an emergency or reduced-traction stop. In normal braking applications, the standard air brake system is in effect.

**IMPORTANT:** For proper ABS system operation, do not mismatch tire sizes among any of the six tires on the vehicle. Mismatching tire sizes could result in a reduced braking force, leading to longer stopping distances and cause an ABS event to register on the ECU (electronic control unit).

Meritor WABCO ABS includes signal-generating tone wheels and sensors located in the wheel hubs of each sensed axle. The sensors transmit vehicle wheel speed information to an electronic control unit (located behind the passenger seat). The control unit's main circuit interprets the wheel speed sensor signals and calculates wheel speed, wheel retardation, and a vehicle reference speed. If the calculations indicate wheel lockup, the main circuit signals the appropriate solenoid control valve to reduce braking pressure. During emergency braking, the solenoid control valve alternately reduces, increases, or maintains air pressure supply in the brake chamber to prevent front and rear wheel lockup.

### **WARNING**

**An accumulation of road salt, dirt, and debris on the antilock braking system (ABS) tone wheels and sensors can cause the ABS warning light to illuminate. If the ABS light comes on, have the ABS serviced. Operating the vehicle when the ABS needs to be serviced could cause an acci-**

**dent, possibly resulting in personal injury or death, or property damage.**

**IMPORTANT:** During winter months in areas where corrosive materials are used on the highways, periodically clean the underside of the vehicle to ensure proper ABS functioning. The required frequency of cleaning will vary with conditions. In general, do not allow corrosive materials to remain on the underside of the vehicle for extended periods of time.

The electronic control unit monitors the wheel sensors, solenoid control valves, and the electrical circuitry. The ABS warning light comes on after turning the ignition switch to the ON position. The warning light goes out only if all of the vehicle's ABS components are working properly.

The Meritor WABCO ABS system combines one front-axle control channel with the rear axle (four-sensor system) to form one control circuit. For example, the sensor and solenoid control valve at the left-front axle form a control circuit with the sensor and solenoid valve on the right-rear axle. If, during vehicle operation, the safety circuit senses a failure in any part of the ABS system (a sensor, solenoid control valve, wiring connections, short circuit, etc.), the ABS warning light comes on and the control circuit where the failure occurred is switched to normal braking action. The remaining control circuit will retain the ABS effect. Even if the ABS system is partially or completely inoperative, normal braking ability is maintained. An exception would be if a solenoid control valve (or combination solenoid control valve) is damaged and inoperative. As these components are an integral part of the air brake system, normal braking may be impaired or inoperative.

### **WARNING**

**If any of the ABS warning lights do not work as described above or come on while driving, repair the ABS system immediately to ensure full antilock braking capability. Operating the vehicle when the ABS needs to be serviced could cause an accident, possibly resulting in personal injury or death, or property damage.**

During emergency or reduced-traction stops, fully depress the brake pedal until the vehicle comes to a safe stop; *do not pump* the brake pedal. With the brake pedal fully depressed, the ABS system will



control all wheels to provide steering control and a reduced braking distance.

## WARNING

Although the ABS system improves vehicle control during emergency braking situations, the driver still has the responsibility to change driving styles depending on existing traffic and road conditions. Failure to change driving styles to accommodate existing traffic and road conditions could cause an accident, possibly resulting in personal injury or death, or property damage.

## Hydraulic Brake System (front-engine diesel chassis)

### General Information

The hydraulic brake system includes a power booster, master cylinder, reservoir, hydraulic lines, a brake rotor on each wheel hub, and a brake caliper and pad assembly at each rotor. See [Fig. 6.2](#).

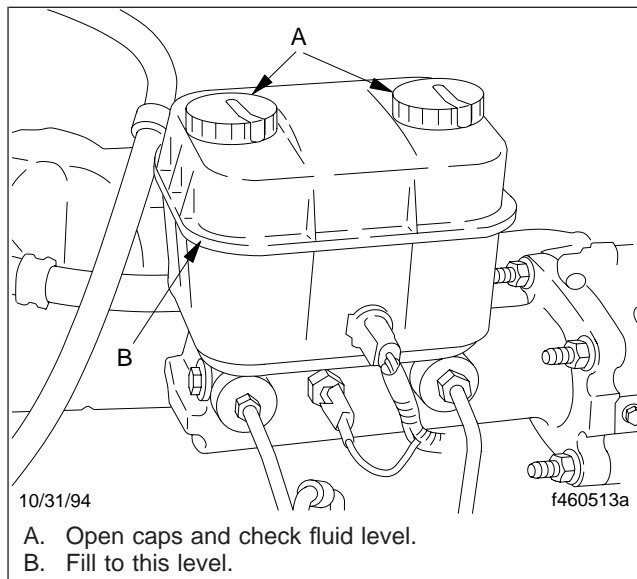

**Fig. 6.2, Hydraulic Brake Reservoir**

**IMPORTANT:** Make sure that the fluid level in the master cylinder reservoirs is up to the flange that surrounds the reservoir. Use only heavy-duty brake fluid, DOT 3, in the hydraulic brake

system. Do not mix types and brands of fluid because of possible incompatibility.

The master cylinder controls braking power to the front and rear brakes. The Bendix Hydro-Max® power booster is attached to the rear of the master cylinder and is connected to the power steering system (which provides pressurized power steering fluid). An electrically powered "reserve" pump operates if there is inadequate fluid flow from the power steering pump to the power booster. The brake system warning light comes on if there is a problem within the system. Bring the vehicle to a safe stop and correct the problem before continuing operation of the vehicle.

## Meritor WABCO® Antilock Braking System (ABS), Hydraulic Brake Systems

The Meritor WABCO Antilock Braking System (ABS) is an electronic wheel speed monitoring and control system that works with the hydraulic brake system. ABS passively monitors vehicle wheel speed at all times, but *controls* wheel speed during an emergency or reduced-traction stop. In normal braking applications, the standard hydraulic brake system is in effect.

**IMPORTANT:** For proper ABS system operation, do not change tire sizes. The sizes of the tires installed during production are programmed into the electronic control unit. Installing different sized tires could result in inaccurate wheel speed signals to the ECU resulting in a reduced braking force, which could lead to longer stopping distances.

ABS includes signal-generating tone wheels and sensors located in the wheel hubs of each sensed axle. The sensors transmit vehicle wheel speed information to an electronic control unit (located on the front-wall) which interprets these signals to calculate wheel speed and a vehicle reference speed. If the calculations indicate wheel lockup, the appropriate control circuit signals the brake pressure modulator to increase or decrease braking pressure until wheelslip has been corrected.

The electronic control unit also has a safety circuit that constantly monitors the wheel sensors, brake pressure modulator, and the electrical circuitry. The dash warning light (ABS) comes on after the ignition

# Brake System

---

is switched on. Once the vehicle moves faster than about 4 mph (6 km/h), the warning light goes out only if all the vehicle's ABS components are working.

If, during vehicle operation, the safety circuit senses a failure in any part of the ABS system (a sensor, brake pressure modulator, wiring connection, short circuit, etc.), the warning light (ABS) comes on and the control circuit where the failure occurred is switched to normal braking action. Even if the ABS system is partially or completely inoperative, normal braking ability is maintained. An exception would be if the brake pressure modulator, or hydraulic fluid line is damaged. As these components are an integral part of the hydraulic brake system, normal braking may be impaired or inoperative.

**IMPORTANT:** If any of the ABS warning lights do not work as described above, or come on while driving, repair the ABS system immediately to ensure full antilock braking capability.

During emergency or reduced-traction stops, fully depress the brake pedal until the vehicle comes to a safe stop; *do not pump* the brake pedal. With the brake pedal fully depressed, the ABS system will control all wheels to provide steering control and a reduced braking distance.

Although the ABS system improves vehicle control during emergency braking situations, the driver still has the responsibility to change driving styles depending on the existing traffic and road conditions. For example, the ABS system cannot prevent an accident if the driver is speeding or following too closely on slippery road surfaces.

## Operation

Before driving the vehicle, secure all loose items in the vehicle so that they will not fly forward during a full brake application. Check that the brake system warning light is off after releasing the parking brake. If the warning light does not go off, correct the problem before continuing operation of the vehicle.

During normal brake stops, depress the foot brake control pedal until braking action slows down the vehicle. Increase or decrease the pressure on the pedal so that the vehicle comes to a smooth, safe stop. When the vehicle comes to a complete stop, shift the transmission into park (P) on the shifter and apply the parking brake.

## CAUTION

**If the vehicle is equipped with an air suspension system, do not park the vehicle or move the vehicle with the air suspension deflated. This may cause suspension component damage.**

## Auto-Apply Parking Brake Operation

Use the following instructions to operate the parking brake:

**IMPORTANT:** The service brake must always be depressed when shifting from the parking brake (Pb) position.

- Set by pressing (Pb) on the shift selector.
- To release the parking brake, depress the service brake and shift from the "Pb" position to any drive gear.
- Shifting from "Pb" to a drive gear and then to neutral (N) releases the parking brake and places the vehicle in neutral. The "BRAKE" warning light will flash when this procedure is performed.
- Shifting directly from "Pb" to "N" does not release the parking brake. "Pb" must be depressed, then a drive gear must be selected to release the parking brake. The "BRAKE" warning light will flash and a chime will sound when this procedure is performed.

# 7

## Pretrip Inspection and Daily Maintenance

---

Pretrip Inspection Checklist .....	7.1
Pretrip Inspection and Daily Maintenance Procedures .....	7.1

# Pretrip Inspection and Daily Maintenance

---

## Pretrip Inspection Checklist

The following pretrip inspection checklist helps ensure that the vehicle components are in good working condition before each trip.

Pretrip inspections cannot be performed in a short period of time. In checklist form, the sequence below may seem to be overly time-consuming. However, careful pretrip inspections save time by eliminating stops later to adjust items overlooked or forgotten.

Each checklist step corresponds with detailed instructions found under "Pretrip Inspection and Daily Maintenance Procedures." If any system or component does not pass this inspection, it must be corrected before operating the vehicle.

**NOTE:** Park the vehicle on a level surface. Shut down the engine, set the parking brake, and chock the tires.

1. Inspect the batteries and battery cables.
2. Check the fluid level in the windshield washer reservoir.
3. Examine the steering components.
4. Check the fluid level in the coolant reservoir. Check the radiator and charge air cooler for clogging or damage. Check the radiator for coolant leaks.
5. Check the condition of the coolant hoses and heater hoses.
6. Check the condition of the drive belts.
7. Inspect the engine for fuel, oil, and coolant leaks.
8. Inspect the engine and chassis wiring.
9. Check the fluid level in the steering system hydraulic fluid reservoir.
10. Check the engine oil level.
11. Check the oil level in the automatic transmission.
12. Check the intake-air restriction indicator.
13. Inspect the fuel tank(s), fuel filters, fuel lines and connections, and other fuel system components.
14. Check the fuel level in the fuel tank(s) and be sure that the fill area is clean.
15. Check the fuel/water separator and drain any water present.
16. Inspect the front and rear suspension components, including the springs and air springs, shocks, and suspension brackets.
17. Check the steering wheel for excessive play.
18. Start the engine and make sure that the oil-pressure warning system is operating. Leave the engine running.
19. Make sure that the horn, windshield wipers and washer, and heater and defroster are operating properly.
20. Make sure that all of the lights are working, including the brake lights, high- and low-beam headlights, turn signals, and emergency flashers. Turn the lights off. Shut down the engine.
21. Inspect the air brake components including the brake chamber pushrods, air reservoirs, and air lines.
22. Check the brake lining wear.
23. Make sure that the brakes are adjusted on all axles.
24. Check the tire inflation pressures, and inspect each tire for bulges, cracks, cuts, and punctures.
25. Check for indications of loose wheel nuts and examine each wheel and components.
26. Check the air brake system for proper operation.
27. Test the service brakes before leaving the lot.
28. Test the parking brake on a 20-percent grade.

## Pretrip Inspection and Daily Maintenance Procedures

---

### CAUTION

---

**An accumulation of road salt, dirt, and debris on the antilock braking system (ABS) tone wheels and sensors can cause the ABS warning light to illuminate. If the ABS light comes on, have the ABS serviced. Operating the vehicle when the ABS needs to be serviced could cause an accident, possibly resulting in personal injury or death, or property damage.**

**IMPORTANT:** During winter months in areas where corrosive materials are used on the highways, periodically clean the underside of the

# Pretrip Inspection and Daily Maintenance

vehicle to ensure proper ABS functioning and to help protect chassis components against corrosion. The required frequency of cleaning will vary with conditions. In general, do not allow corrosive materials to remain on the underside of the vehicle for extended periods of time.

**NOTE:** Drain the air tanks at least every six months.

Air reservoirs serve as storage tanks for compressed air. They collect water condensed from the air and small amounts of oil that enter the reservoir in the form of vapor, due to the heat generated during compression.

After the water and oil condense, they collect near the tank drain valves. Drain the resulting emulsion as follows:

There are three separate pull-cables for draining the air tanks. Pull and hold each of the three cables until all moisture is gone.

## **WARNING**

When draining the air reservoir, do not look into the air jets or direct them towards anyone. Dirt or sludge particles may be in the airstream and could cause injury.

Failure to drain the air reservoirs as instructed could cause sludge formation in the air brake system. Sludge could adversely affect braking, causing loss of control, which could cause death, personal injury, or property damage.

1. *Inspect the batteries and battery cables.*

## **WARNING**

Battery posts, terminals, and related accessories contain lead and lead compounds, chemicals known to the State of California to cause cancer and reproductive harm. To prevent possible personal injury, always wash your hands after handling battery parts and related accessories.

- 1.1 Be sure that the battery hold-down is secure. If it is loose, tighten the hold-down bolts; if it is broken, replace it.

## **CAUTION**

Take care to keep the vent plugs tight so that the neutralizing solution does not enter any of the battery cells and damage the battery.

- 1.2 Remove any corrosion from the hold-down and the top of the battery. Use diluted ammonia or a soda solution to neutralize the acid present, then rinse off the ammonia or soda solution with clean water.

If the battery posts or cable terminals are corroded, disconnect the terminals from the posts. Clean them with a soda solution and a wire brush. After cleaning, connect the terminals to the battery posts, then apply a thin coat of petroleum jelly to the posts and terminals to help retard corrosion.

2. *Check the fluid level in the windshield washer reservoir.*

Add washer fluid as needed.

## **WARNING**

Washer fluids may be flammable and poisonous. Do not expose washer fluid to an open flame or any burning material, such as a cigarette. Always comply with the washer fluid manufacturer's recommended safety precautions.

3. *Examine the steering components.*

Examine the steering gear mounting bolts, pitman arm nut, and the drag link nuts for tightness. See [Fig. 7.1](#). Check for leakage at the gear box. Be sure that the steering driveline and the U-joints are in roadworthy condition, without cracks, breaks, looseness, or other damage. Tighten loose nuts and replace damaged parts as needed.

4. *Check the fluid level in the coolant reservoir. See [Fig. 7.2](#), [Fig. 7.3](#), or [Fig. 7.4](#). Check the radiator and charge air cooler for clogging or damage. Check the radiator for coolant leaks.*

# Pretrip Inspection and Daily Maintenance

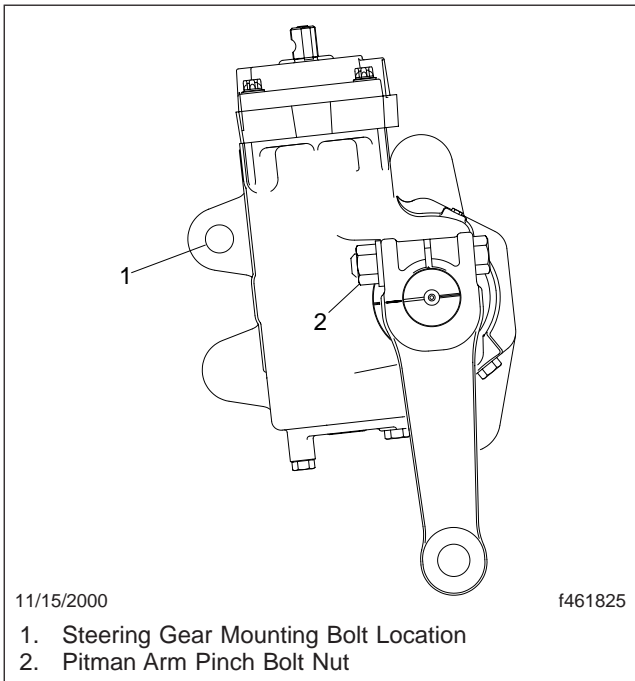

**Fig. 7.1, TRW Steering Gear Installation**

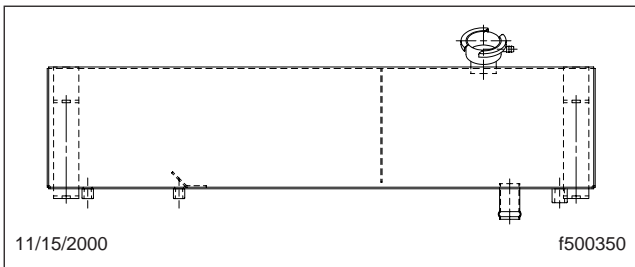

**Fig. 7.2, Coolant Reservoir (used with rear radiator)**

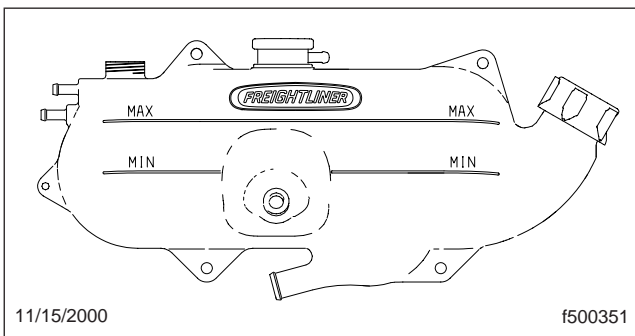

**Fig. 7.3, Coolant Reservoir (used with side radiator)**

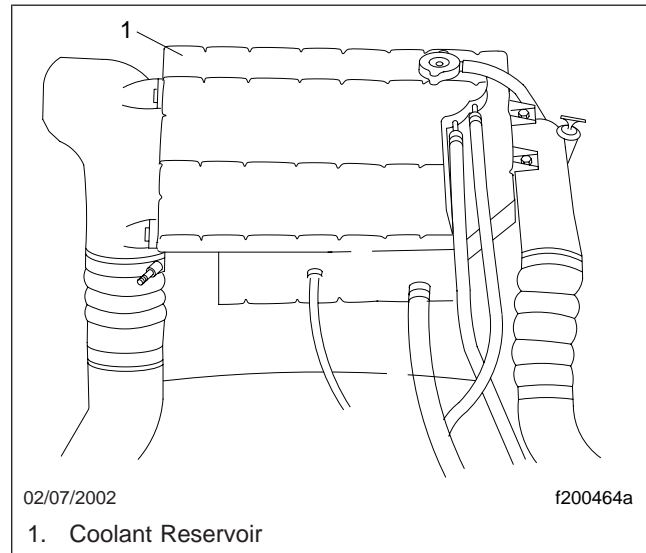

**Fig. 7.4, Coolant Reservoir (used with side radiator)**

## CAUTION

**Coolant must be filled to the full line of the surge tank. Low coolant could result in engine overheating, which could cause engine damage.**

**IMPORTANT:** Do not confuse coolant with hydraulic fluid. Both are pink in color.

- 4.1 If the coolant is low, check the amount of antifreeze protection. If the protection is adequate, add a 50/50 mixture of water and antifreeze. If additional protection is needed, add antifreeze only.

**NOTE:** Good airflow through the radiator core and charge air cooler is essential for proper engine cooling. The cores allow air passage, but form a particle barrier which tends to collect insects and airborne debris.

- 4.2 Inspect for clogged fins. Use compressed air or water to backflush any material restricting airflow.
- 4.3 Inspect and clean the charge air cooler.
- 4.4 Straighten bent or damaged fins to permit airflow across all areas of the cores.
- 4.5 Repair or replace the radiator if it is leaking.



# Pretrip Inspection and Daily Maintenance

5. Check the condition of the coolant hoses and heater hoses.

Make sure that the radiator inlet and outlet coolant hoses and heater hoses are pliable, and are not cracking or bulging. Replace hoses that show signs of cracking, weakening, or bulging. Replace all hoses, including the heater hoses, at the same time. Service-type knitted or braided yarn-reinforced neoprene hose is acceptable.

Tighten hose clamps as necessary, but do not overtighten, as hose life can be adversely affected.

Be sure that the hose support brackets are securely fastened. Make sure that the hoses are not located near sources of wear, abrasion, or high heat.

6. Check the condition of the drive belts.

Check the fan belt(s), alternator belt, and refrigerant compressor belt for signs of glazing, wear (frayed edges), damage (breaks or cracks), or oil contamination. If a belt is glazed, worn, damaged, or oil soaked, replace the belt.

**NOTE:** A belt tensioner automatically adjusts the fan and alternator belt to the correct tension. If the belt slips, repair or replace the tensioner. For instructions, see the *Caterpillar, Cummins, or the Mercedes-Benz Operation and Maintenance Manual*.

7. Inspect the engine for fuel, oil, and coolant leaks. Correct any leaks found.
8. Inspect the engine and chassis wiring. Inspect the engine and chassis for loose wiring, chafed insulation, and damaged or loose hold-down clamps. Tighten loose wires or hold-down clamps; replace damaged wiring or clamps.
9. Check the fluid level in the steering system hydraulic fluid reservoir. See [Fig. 7.5](#).

If needed, fill the reservoir to a level between the MIN and MAX marks. Use only Dexron® III ATF, or an equivalent.

**IMPORTANT:** Do not confuse coolant with hydraulic fluid. Both are pink in color.

10. Check the engine oil level.

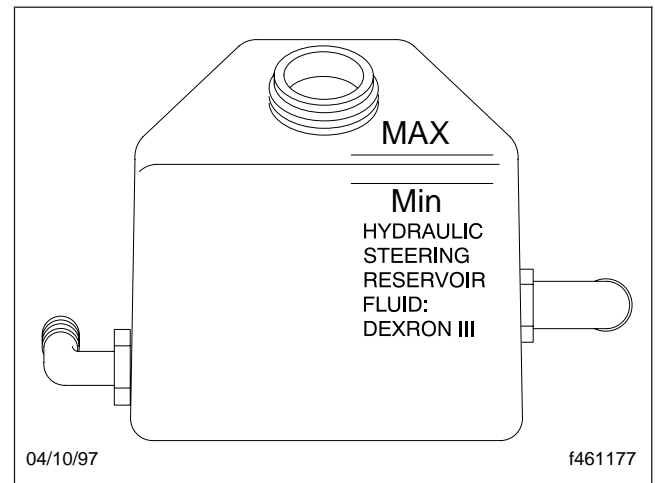

**Fig. 7.5, Steering System Hydraulic Fluid Reservoir**

The oil level should show between the upper and lower marks on the dipstick. Add enough oil to bring the level up to the operating range. See the *Caterpillar, Cummins, or the Mercedes-Benz Operation and Maintenance Manual* for recommended lubricants and capacities.

## **CAUTION**

**Maintain the correct engine oil level. Operating the engine with the oil level below the low mark or above the high mark could result in engine damage.**

11. Check the oil level in the automatic transmission. See [Fig. 7.6](#) and [Fig. 7.7](#).

**NOTE:** The automatic transmission fluid must be warm to ensure an accurate check. The fluid level rises as temperature increases. Check the oil level with the vehicle on a level surface.

- 11.1 Operate the transmission in a Drive (D) range until normal operating temperature, 160 to 200°F (71 to 93°C), is reached.
- 11.2 Park the vehicle. Set the parking brake, and place the transmission in the Neutral (N) position. Let the engine run at idle.
- 11.3 Wipe the dipstick clean and check the fluid level. A safe operating level is any level within the HOT run (upper) band on the dipstick. See [Fig. 7.8](#).

# Pretrip Inspection and Daily Maintenance

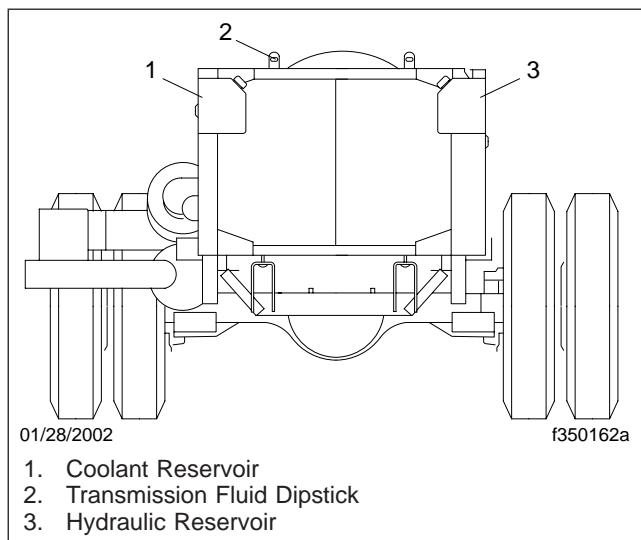

**Fig. 7.6, Transmission Fluid Level Check**

- 11.4 If the fluid is not within this range, add or drain fluid as needed to bring the level to the top of the HOT run band. See **Table 7.1** for fluid types and capacities.

**IMPORTANT:** For all transmissions, use TranSynd synthetic automatic transmission fluid (ATF).

**NOTE:** A cold check may be made when the sump temperature is 60 to 104°F (15 to 40°C). Follow the substeps below.

- 11.5 Run the engine for at least one minute to clear the fluid system of air.

Transmission Lubricant Capacities	
Model	Refill Capacity*†: quarts (liters)
1000, 2000, 2000 MH, and 2100	16.0 (15.1)
3000 MH and 4000 MH	17.5 (16.5)

\* Quantities listed are approximate. Add the recommended amount of fluid as listed under refill capacity, then perform a "hot check" and add fluid as needed. Do not overfill.

† NOTE: Some Allison 3000 MH transmissions have a deeper oil sump than other models. These models require 3 additional quarts (2.8 L) of automatic transmission fluid (ATF).

**Table 7.1, Transmission Lubricant Capacities**

- 11.6 With the engine running, wipe the dipstick clean and check the fluid level. Any level within the COLD run (lower) band is satisfactory for operating the vehicle. If the

level is not within the COLD run band, add or drain fluid until it reaches the middle of the COLD run band.

- 11.7 Perform a hot check at the first opportunity after normal operating temperature, 160 to 200°F (71 to 93°C), is reached.
12. Check the intake-air restriction indicator to determine if the air cleaner filter element needs to be changed. See **Fig. 7.9**.

Replace the air cleaner element when the yellow line reaches 25 inH<sub>2</sub>O vacuum or every two years, regardless of mileage. After the air cleaner element is replaced, press the button on the bottom of the air restriction indicator to reset it.

## CAUTION

**Failure to maintain a sealed air intake system could allow the entry of dirt and contaminants into the engine. This could adversely affect engine performance and result in engine damage.**

**NOTE:** The final manufacturer mounts the air restriction indicator. It is typically mounted in the same area as the other routine engine service check items, i.e., dipstick, fluid reservoirs.

13. Inspect the fuel tank(s), fuel filters, fuel lines and connections, and other fuel system components.

Replace leaking fuel tanks; repair or replace any mechanisms, lines, or connections that are leaking.

14. Check the fuel level in the fuel tank(s) and be sure that the fill area is clean. To keep condensation to a minimum, the fuel tanks should be filled at the end of each day, but not to more than 95-percent of liquid capacity. Federal regulations prohibit filling a fuel tank to more than 95-percent of its liquid capacity. Select the proper grade of fuel, as specified by the engine manufacturer.

## WARNING

**Never fill fuel tanks to more than 95 percent of their liquid capacity. This could make them more likely to rupture from impact, possibly causing fire and resulting in serious personal injury or death by burning.**



# Pretrip Inspection and Daily Maintenance

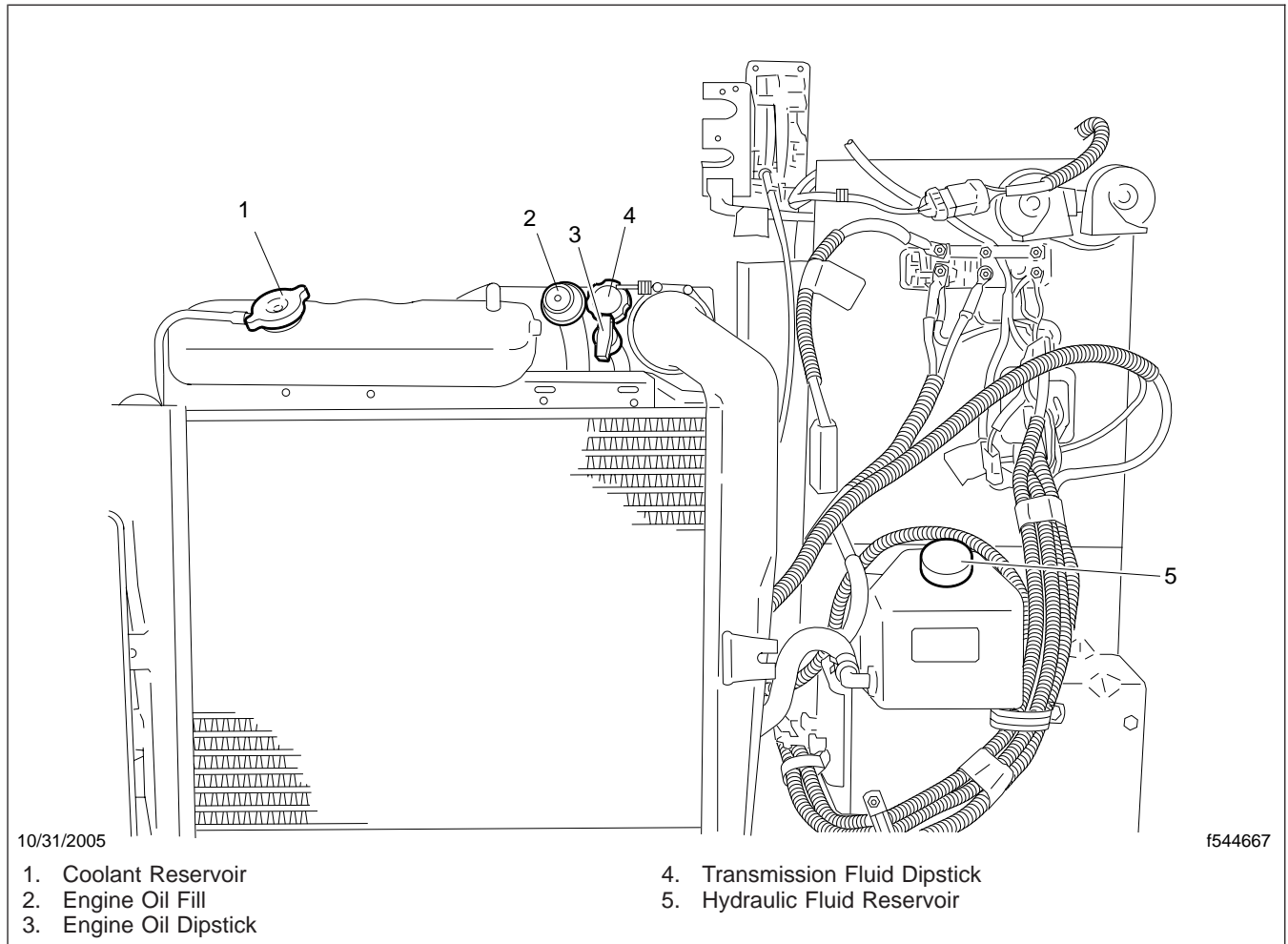

**Fig. 7.7, Transmission Fluid Level Check (front-engine diesel chassis)**

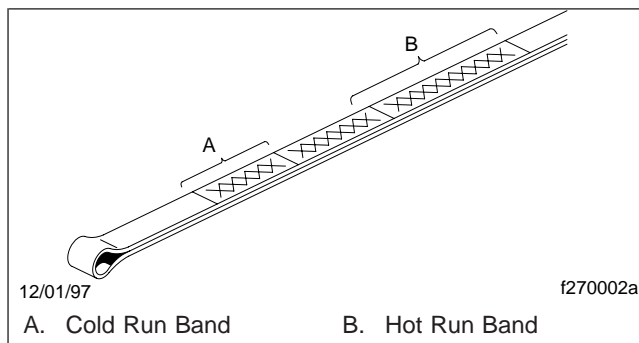

**Fig. 7.8, Automatic Transmission Dipstick Markings**

resulting in serious personal injury or death. Do not fill the fuel tanks in the presence of sparks, open flames, or intense heat. These could ignite the fuel, possibly causing severe burns.

**IMPORTANT:** Use only low-sulfur diesel fuels. Low-sulfur diesel fuels have a maximum 0.05 percent sulfur content, compared to a 0.26 to 0.30 percent sulfur content for some other fuels. Failure to use low-sulfur diesel fuels may void the warranty on emissions components.

**Do not mix gasoline or alcohol with diesel fuel. This mixture could cause an explosion, possibly**

# Pretrip Inspection and Daily Maintenance

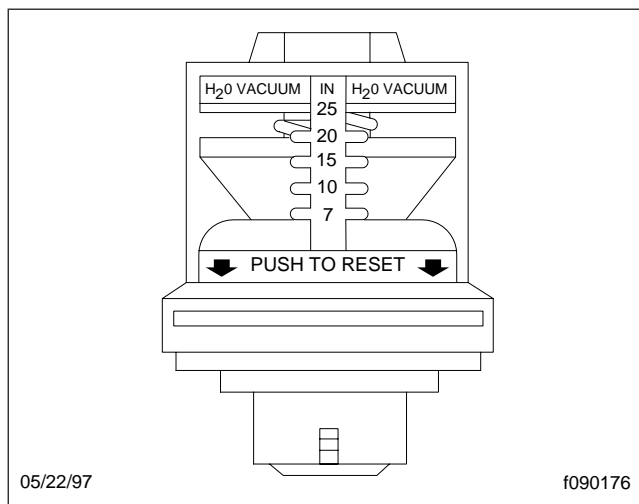

**Fig. 7.9, Air Restriction Indicator**

- 14.1 Fuel should always be strained or filtered before it is put into the tanks. This will lengthen the life of the engine fuel filter, and reduce the chances of dirt getting into the engine.
- 14.2 Before installing the fuel cap, check the filler area. Clean the filler area with a rag, or if necessary, clean the cap with solvent.

## **CAUTION**

**Water in the fuel/water separator will appear as beads. Drain the separator only enough to remove the water. Do not drain the separator completely or it will be necessary to prime the fuel system before the vehicle may be started again.**

**IMPORTANT:** On all types of separators, stop draining fluid when you see clear fuel (and no more water) come out of the separator drain valve. Drain the fluid into an appropriate container and dispose of it properly.

15. *Check the fuel/water separator and drain any water present.*

**NOTE:** The fuel/water separator may be relocated by the body manufacturer and the locations may vary.

- 15.1 Shut off the engine.
- 15.2 Remove the fuel cap.

- 15.3 Open the valve until draining occurs. Drain the filter sump of water until clear fuel is visible.
  - 15.4 Close the drain and install the fuel cap.
  - 15.5 Run the engine and check for leaks.
16. *Inspect the front and rear suspension components, including the springs and air springs, shocks, and suspension brackets.*

Check for broken spring leaves, loose U-bolts, cut or ruptured air springs (bags), cracks in the suspension brackets, and loose fasteners in the spring hangers and shackles. Inspect the shock absorbers for loose fasteners and leaks.

Tighten all loose fasteners. Replace any component that is worn, cracked, or otherwise damaged.

## **WARNING**

**Do not replace individual leaves of a damaged front or rear suspension leaf spring assembly; replace the complete spring assembly. Visible damage, such as cracks or breaks, to one leaf causes hidden damage to other leaves. Replacement of only the visibly damaged part(s) is no assurance that the spring is safe. If cracks or breaks exist on front spring assemblies in either of the two top leaves, a loss of vehicle control could occur. Failure to replace a damaged spring assembly could cause an accident resulting in serious personal injury or property damage.**

17. *Check the steering wheel for excessive play.*

With the front tires pointing straight ahead, turn the steering wheel until motion is observed at the front wheels. Align a reference mark on a ruler See **Fig. 7.10**, then slowly turn the steering wheel in the opposite direction until motion is again detected at the wheels. Measure the lash (free play) at the rim of the steering wheel.

Excessive lash exists if steering wheel movement exceeds 4-3/4 inches (121 mm) with an 18-inch (470-mm) steering wheel. If there is excessive lash, check the steering system for wear or incorrect adjustment of the linkage and steering gear before operating the vehicle.

18. *Start the engine and make sure that the oil-pressure warning system is operating.*

# Pretrip Inspection and Daily Maintenance

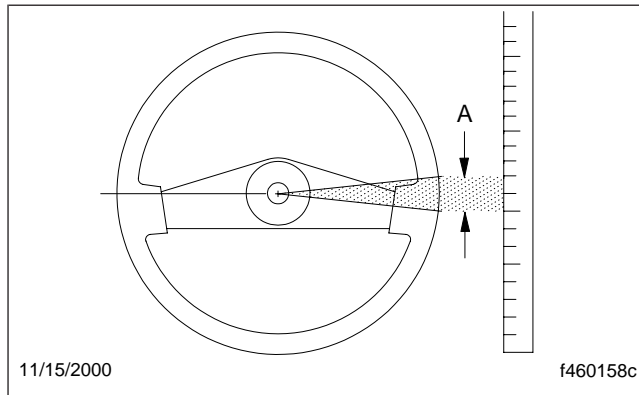

**Fig. 7.10, Measuring Lash at the Steering Wheel**

When the engine is started, the oil-pressure warning light will come on until the oil pressure rises above a preset minimum.

If the warning light does not come on when the ignition switch is turned to the ON position, repair the system.

19. Make sure that the horn, windshield wipers and washer, and heater and defroster are operating properly.

20. Make sure that all of the lights are working.

Turn on the headlights, dash lights, and emergency flashers.

Turn all of the lights off. Shut down the engine.

## DANGER

Do not loosen or remove the parking brake clamp ring for any purpose. See Fig. 7.11. The parking/emergency brake section of the brake chamber is not intended to be serviced. Serious injury or death may result from sudden release of the power spring.

Before doing any repairs or adjustments on a service/parking brake chamber, read the applicable warnings and instructions in Group 42 of the *Recreational Vehicle Chassis Workshop Manual*.

## WARNING

Do not operate the vehicle with the front brakes backed off or disconnected. Backing off or disconnecting the front brakes will not improve ve-

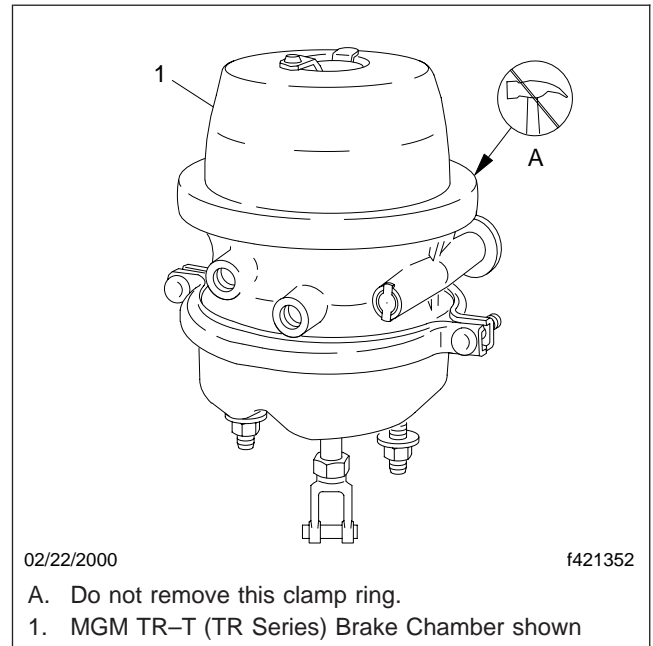

**Fig. 7.11, Parking Brake Chamber Clamp**

hicle handling and may lead to loss of vehicle control resulting in property damage or personal injury.

## CAUTION

If the brake chamber external breather tube or breather cap is missing or incorrectly installed, road dirt and debris can adversely affect the operation of the brake chamber. Once inside the chamber, dirt and debris cause the internal parts to deteriorate and shorten their lives.

21. Inspect the air brake components including the brake chamber pushrods, air reservoirs, and air lines.

Inspect the front air brake lines for leaks at the fitting where they enter the air chamber.

With an assistant at the front wheels to inspect the brake lines, turn the wheels to full lock in one direction. While holding the service brake pedal down, inspect the front brake air lines closely where they enter the air chambers.

Turn the wheels to full lock in the other direction, hold the service brake pedal down, and repeat the inspection.

# Pretrip Inspection and Daily Maintenance

If there is a leak, the hose should be replaced. See **Group 42** of the *Recreational Vehicle Chassis Workshop Manual* for the hose replacement procedure.

Look for worn clevis pins on brake chamber pushrods and missing or damaged cotter keys on the brake chamber pushrod clevis keys. Replace worn clevis pins and install new cotter pins if necessary.

Visually inspect the piston rod engagement with the clevis. At least 7 threads of engagement are required; there should be 1 inch (25 mm) of clearance from the centerline of the clevis pin hole to the end of the piston rod. See **Fig. 7.12**. See **Group 42** of the *Recreational Vehicle Chassis Workshop Manual* for adjustment procedures.

See if the chamber piston rod is in line with the slack adjuster. Misalignment can cause the piston rod to rub on the nonpressure chamber and cause a dragging brake. See **Group 42** of the *Recreational Vehicle Chassis Workshop Manual* if the chamber piston rod is improperly aligned.

Visually inspect the exterior surfaces of the chamber for damage. Make sure that breather holes in the nonpressure section(s) are open and free of debris. See **Group 42** of the *Recreational Vehicle Chassis Workshop Manual* to replace any damaged parts.

On all parking brake installations, check for the presence of an end cover cap or dust plug and make sure that the cap or plug is securely snapped into place. On most MGM parking brake chambers equipped with an integral release bolt, an end cover cap is installed over the release bolt. Be sure that the end cover cap is snapped tightly into place.

Check for rusted connections, missing snap rings, and damaged camshaft grease seals. Repair or replace damaged or missing parts.

Check the air reservoir band fasteners. Make sure that the outside surfaces of the reservoirs are painted to prevent corrosion damage. Inspect the reservoir surfaces for damage, such as cracks and dents. Replace corroded or damaged reservoirs with new ones. Do not repair damaged reservoirs. Old or used reservoirs are not acceptable as replacements. If a reservoir requires replacement, see **Group 42** of the *Recreational*

*Vehicle Chassis Workshop Manual* for instructions.

Inspect the air lines as follows:

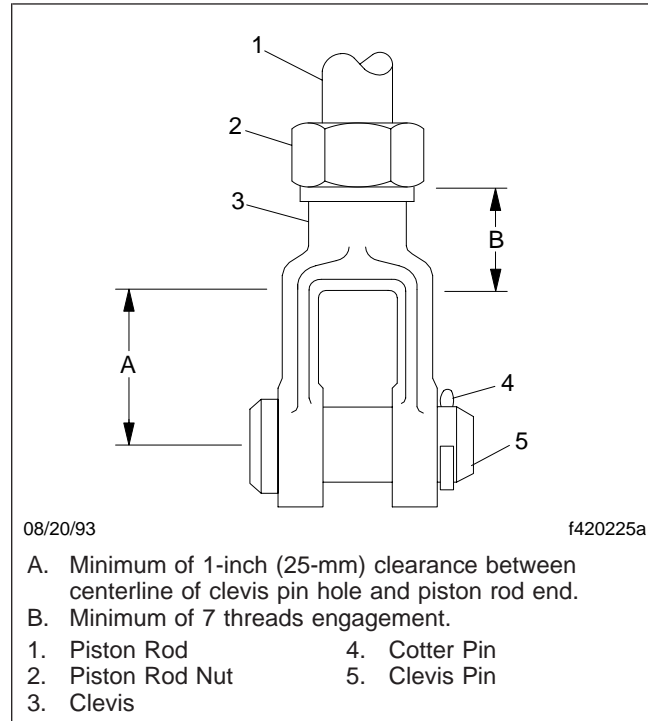

**Fig. 7.12, Piston Rod Engagement With the Clevis**

- 21.1 Check the clearance between the hoses, exhaust manifold, and turbocharger, or other hot spots. Excessive heat will cause the material in the hoses to deteriorate rapidly or become brittle. Provide at least 6 inches (150 mm) of clearance. More clearance is recommended if the hose is located above the heat source.
- 21.2 Check for kinks, dents, or swelling of the hoses. If a hose is damaged, replace it with the same size and type.  

Do not route the hose on top of anything likely to be stepped on or walked on.
- 21.3 Check for damage to hoses located near moving parts, such as drivelines, suspensions, and axles. If the moving parts are catching or pinching the lines, correct as needed.

# Pretrip Inspection and Daily Maintenance

21.4 Check for hose damage caused by abrasion. If a hose is abraded, replace it. Check for the cause of abrasion, such as loose or damaged hose clamps. Repair or replace the clamps as needed.

21.5 Observe the hose cover condition, especially hoses exposed to water splash and ice. If any hose is dried out or ragged (the wire or liner is showing through the cover), replace the hose.

21.6 Inspect air tubing, especially tubing made of nylon. In cold weather, nylon tubing is sensitive to damage, such as nicks or cuts. Replace nicked or cut tubing, even if it is not leaking.

21.7 Check the bend radii of all hoses. See **Fig. 7.13**. The minimum bend radius of a hose is that bend which the hose will withstand without experiencing damaging stresses or kinking. For minimum bend radius values, see **Group 42** of the *Recreational Vehicle Chassis Workshop Manual*.

When a rubber hose bend does not meet minimum radius requirements, the outside may appear smooth even if the inner tube is kinked. Reroute the hose or replace it with one of adequate length if the bend radius is not within minimum specifications.

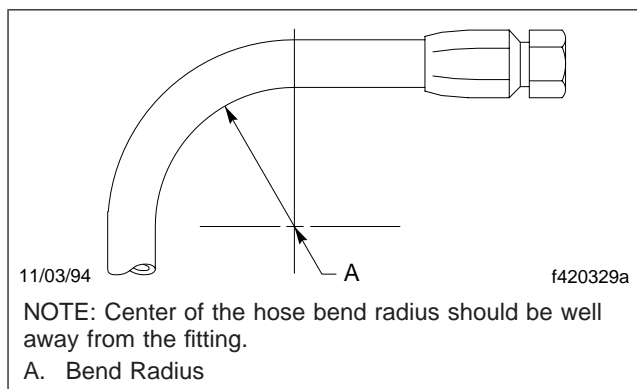

**Fig. 7.13, Bend Radius**

21.8 Check straight hose installations (those hoses that do not bend along their routings). Pressure changes can cause a hose to lengthen up to 2-percent, or shorten up to 4-percent. A 100-inch (2540-

mm) length of hose, for example, can contract to 96 inches (2440 mm). If the hose has no slack when it is exhausted of air, replace it with one of adequate length to avoid a possible blow-off from the fitting during vehicle operation.

21.9 Check for kinked or twisted hoses. A 7-percent twist in the hose can reduce its life by up to 90-percent. Also, a twisted hose under pressure tends to untwist. This could cause it to loosen the fitting. Reconnect hoses that are twisted.

22. *Check the brake lining wear on vehicles equipped with air brakes. Proper brake operation is dependant on periodic maintenance and inspection of the brake linings.*

22.1 If the axle assembly is not equipped with a dust shield or backing plate, measure the axle brake lining thickness. If *any* of the brake linings are worn to less than 1/4 inch (6.5 mm) at the thinnest point, replace the linings on *all* brake assemblies on that axle. See **Group 42** of the *Recreational Vehicle Chassis Workshop Manual* for lining replacement instructions and camshaft endplay inspection.

22.2 If the axle assembly is equipped with a dust shield or backing plate, remove the inspection plugs to inspect the brake lining thickness. If *any* of the brake linings are worn to less than approximately 1/4 inch at the thinnest point, replace the linings on *all* brake assemblies on that axle. See **Group 42** of the *Recreational Vehicle Chassis Workshop Manual* for lining replacement instructions and camshaft endplay inspection.

22.3 Install the inspection plugs in the dust shields or backing plates if equipped.

23. *Make sure that the brakes are adjusted on all axles.*

Adjust the brakes if necessary. See **Group 42** of the *Recreational Vehicle Chassis Maintenance Manual* for checking and adjusting procedures.

**IMPORTANT:** Brake checking and adjusting is necessary for all vehicles, including those equipped with automatic slack adjusters.



# Pretrip Inspection and Daily Maintenance

24. Check the tire inflation pressures, and inspect each tire for bulges, cracks, cuts, and punctures.

**IMPORTANT:** The load and cold inflation pressure must not exceed the wheel manufacturer's recommendations, even though the tire may be approved for a higher load or inflation. Some wheels are stamped with a maximum load and maximum cold inflation rating. If the load exceeds the maximum wheel capacity, the load must be adjusted or reduced. See and adhere to the tire load and cold inflation pressure specifications stated on the vehicle specification label.

**NOTE:** Tire load limits refer only to individual tires and do not indicate the weights for the entire axle.

- 24.1 Check the inflation pressures of the tires before each trip, using an accurate tire pressure gauge. See **Fig. 7.14**. Check tire pressures when the tires are cool. The maximum inflation pressure for each tire is provided on the outer wall of the tire. Inflate the tires to the applicable pressures, if needed. Be sure that valve stem caps are used on every tire, and that they are screwed on finger-tight.

When traveling at unusual speeds, use **Table 7.2** to adjust tire pressure.

For later vehicles with Michelin tires, see the *Michelin Recreational Vehicle Tire Guide* for correct tire inflation pressures for the vehicle load.

Overinflation gives the treaded surface of the tire a convex shape. See **Fig. 7.15**. This causes premature tire wear in the middle part of the tire since this section is primarily in contact with the road.

Underinflation gives the tread surface a concave shape. See **Fig. 7.15**. This causes excessive tire wear on the outer edges of the tire since those edges are primarily in contact with the road.

Variations in Load and Inflation Limits According to Speed		
Speed Range mph (km/h)	Inflation Pressure Increase in psi (kPa)	Percent Increase/ Decrease in Load
70 to 75 (113 to 121)	10 (69)	(-10)
61 to 70 (98 to 113)	10 (69)	0
51 to 60 (82 to 97)	0	0
41 to 50 (66 to 80)	0	+9
31 to 40 (50 to 64)	0	+16
21 to 30 (34 to 48)	10 (69)	+24
11 to 20 (18 to 32)	15 (103)	+32

**Table 7.2, Variations in Load and Inflation Limits According to Speed**

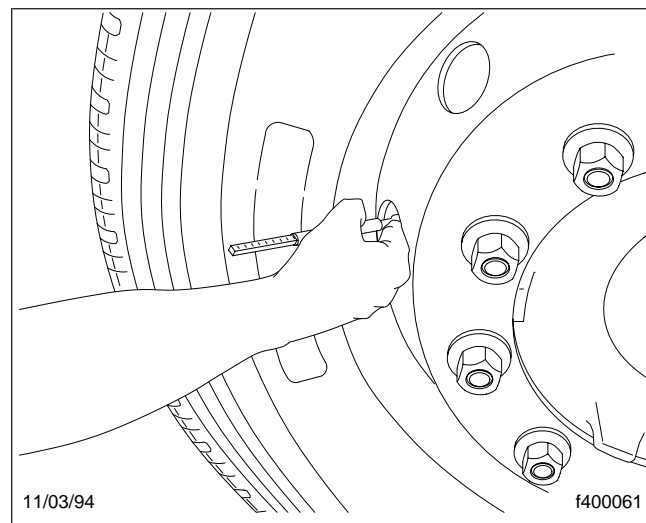

**Fig. 7.14, Check Tire Pressures**

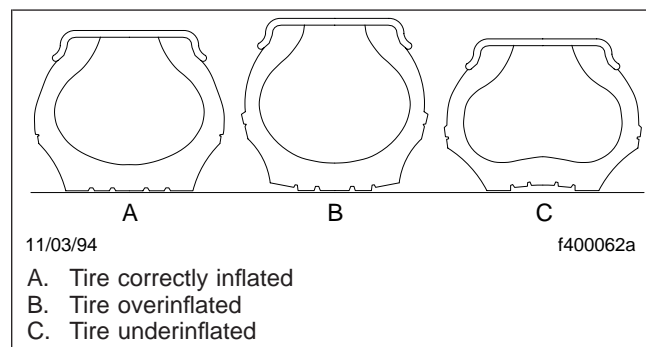

**Fig. 7.15, Check Tire Inflation**

# Pretrip Inspection and Daily Maintenance

## WARNING

Do not operate the vehicle with underinflated or overinflated tires. Incorrect inflation can stress the tires and make the tires and rims more susceptible to damage, possibly leading to rim or tire failure and loss of vehicle control, resulting in serious personal injury or death.

- 24.2 If a tire has been run flat or underinflated, before adding air, check for possible wheel or tire damage.

**IMPORTANT:** Moisture inside a tire can result in body ply separation or a sidewall rupture. During tire inflation, compressed air reservoirs and lines must be kept dry. Service inline moisture traps regularly.

- 24.3 Inspect the tires for bulges, cracks, cuts, or penetrations. A tire pressure check will assist in uncovering hidden damage; a weekly pressure loss of 4 psi (28 kPa) or more in a tire may indicate damage, and the tire should be inspected and repaired or replaced.

- 24.4 If the tires are wearing irregularly, see the tire manufacturer's recommendations. Have the front axle alignment checked to determine the cause of irregular tire wear.

Government regulations require the removal of front axle tires at 4/32-inch (3-mm) remaining tread depth and rear axle tires at 2/32-inch (1.5-mm) remaining tread depth.

- 24.5 Inspect the tires for oil contamination. Fuel oil, gasoline, and other petroleum derivatives, if allowed to contact the tires, will soften the rubber and destroy the tire.

**IMPORTANT:** Do not use tire dressings. These will cause premature wear and deterioration of the tire material. Use only soap and water to clean tires.

## WARNING

On vehicles equipped with ZF independent front suspension (IFS) and ZF SB 7000 front air disk brakes, the only approved front wheels and valve stems are those that come on the chassis as de-

livered from the FCCC manufacturing plant. These wheels have a special bolt pattern. Valve stems other than those delivered with the chassis may interfere with the brake calipers. The use of unapproved front wheels and/or front wheel valve stems could cause component damage and result in personal injury or death, or property damage.

**IMPORTANT:** Rinse the Accuride® Accu-Shield™ wheels with high-pressure water to remove any debris. Use a cotton cloth dipped in a mild soap solution to help remove stuck on dirt and grease. Rinse the remaining soap residue from the wheels. Dry the wheels thoroughly with a cotton cloth.

25. Check for indications of loose wheel nuts and examine each wheel and components.

Check the wheel nuts for indications of looseness. Remove all dirt and foreign material from the assembly. Dirt or rust streaks from the stud holes, metal buildup around stud holes, or out-of-round or worn stud holes may be caused by loose wheel nuts. Tighten the wheel nuts to the correct torque specifications in the proper tightening sequences. See **Group 40** of the *Recreational Vehicle Chassis Maintenance Manual* for instructions.

Examine the wheel assembly components (including rings, flanges, studs, and nuts) for cracks or other damage.

Replace broken, cracked, badly worn, bent, rusty, or sprung rings. Be sure that the lockring and side ring are matched according to size and type.

## WARNING

Have any worn or damaged wheel components replaced by a qualified person using the wheel manufacturer's instructions and the wheel industry's standard safety precautions and equipment. Otherwise a vehicle or workshop accident could occur, possibly resulting in serious personal injury or death.



# Pretrip Inspection and Daily Maintenance

## CAUTION

Insufficient wheel nut torque can cause wheel shimmy, resulting in wheel damage, stud breakage, and extreme tire tread wear. Excessive wheel nut torque can break studs, damage threads, and crack discs in the stud hole area. Use the recommended torque values and follow the proper tightening sequence.

26. Check the air brake system for proper operation.

26.1 Release the parking brake by pushing in the parking brake control valve knob. Check the air governor cut-in and cut-out pressures. Run the engine at fast idle. The air governor should cut out the air compressor at approximately 125 psi (862 kPa). With the engine idling, make a series of foot valve applications. The air governor should cut in the air compressor at approximately 95 psi (655 kPa). If the air governor does not cut in and out as described above, it must be adjusted to these specifications. If the air governor cannot be adjusted or repaired, replace it before operating the vehicle.

26.2 Check air pressure buildup time as follows:  
Release the parking brake by pushing in the parking brake control valve knob.

With the air system fully charged to 125 psi (862 kPa), make one full brake application and note the air pressure reading on the gauge. Continue to reduce the air pressure by moderate brake applications to a maximum of 90 psi (620 kPa), then run the engine at governed rpm. If the time required to raise the air pressure to 125 psi (862 kPa) is more than 30 seconds, eliminate any leaks or replace the air compressor before operating the vehicle.

26.3 Check the air pressure reserve. With the air system fully charged to 125 psi (862 kPa), stop the engine and note the air pressure. Then make one full brake application and observe the pressure drop. If it

drops more than 25 psi (172 kPa), all areas of leakage must be eliminated before operating the vehicle.

## WARNING

Before operating the vehicle, be sure that the parking brake passes the following tests. Otherwise an unexpected parking brake application could occur, causing some loss of vehicle control and possibly resulting in serious personal injury.

26.4 Check the air leakage in the system.

With the parking brake applied, the transmission out of gear, and the tires chocked, charge the air system until cutoff pressure of 125 psi (862 kPa) is reached.

With the service brakes released, shut down the engine, wait one minute and note the air pressure gauge reading. Observe the air pressure drop in psi (kPa) per minute.

Charge the air system until cutoff pressure of 125 psi (862 kPa) is reached. With the parking brake released and the service brake applied, shut down the engine, wait one minute and note the air pressure gauge reading. Observe the air pressure drop in psi (kPa) per minute.

If leakage exceeds the limits shown in [Table 7.3](#), repair all areas of leakage before driving the vehicle.

Maximum Allowable Service Brakes Air Leakage	
Brakes Released	Brakes Applied
2 psi (14 kPa)	3 psi (21 kPa)

**Table 7.3, Maximum Allowable Service Brakes Air Leakage**

27. Test the service brakes before leaving the lot.

Depress the brake pedal, release the parking brake, and check that the brake system warning light goes off. If the warning light remains on after releasing the parking brake, correct the problem before driving the vehicle.

28. Test the parking brake on a 20-percent grade.

## Pretrip Inspection and Daily Maintenance

---

Apply the parking brake with the vehicle on a 20-percent grade (or as steep a grade as the vehicle may normally be parked on). The ramp surface should be made of Portland cement or the equivalent. If the parking brake does not hold the vehicle, repair the parking brake system.

# 8

## In an Emergency

---

Freightliner Help .....	8.1
Hazard Warning Lights .....	8.1
Towing .....	8.1
Emergency Starting With Jumper Cables .....	8.1
Changing a Flat Tire .....	8.2
Running Out of Fuel .....	8.3

# In an Emergency

## Freightliner Help

In the event of a vehicle emergency, call the Customer Assistance Center at 1-800-385-4357 or 1-800-FTL-HELP. Call night or day, weekdays or weekends, for dealer referral, vehicle information, or breakdown coordination.

## Hazard Warning Lights

Pull out the hazard warning light switch on the steering column to activate the hazard warning lights. When the hazard warning light switch is pulled out, all of the turn signal lights and both of the turn signal indicator lights on the control panel will flash. To cancel the warning lights, push the switch in.

## Towing

See [Chapter 10](#) for towing information.

## Emergency Starting With Jumper Cables

When using jumper cables, follow the instructions below.

### WARNING

Batteries release explosive gas. Do not smoke when working around batteries. Put out all flames and remove all sources of sparks or intense heat in the vicinity of the battery. Do not allow the vehicles to touch each other. Do not lean over the batteries when making connections, and keep all other persons away from the batteries. Failure to follow these precautions could lead to severe personal injury as a result of an explosion or acid burns.

### CAUTION

Make sure that both starting systems have the same voltage outputs and avoid making sparks. Otherwise the vehicle charging systems could be severely damaged. Also, do not attempt to charge isolated, deep-cycle batteries with jumper cables; follow the manufacturer's instructions when charging deep-cycle batteries.

1. Apply the parking brakes and turn off the lights and all other electrical loads.
2. Connect one end of a jumper cable to the positive terminal of the booster battery and connect the other end of the cable to the positive terminal of the discharged battery. See [Fig. 8.1](#).

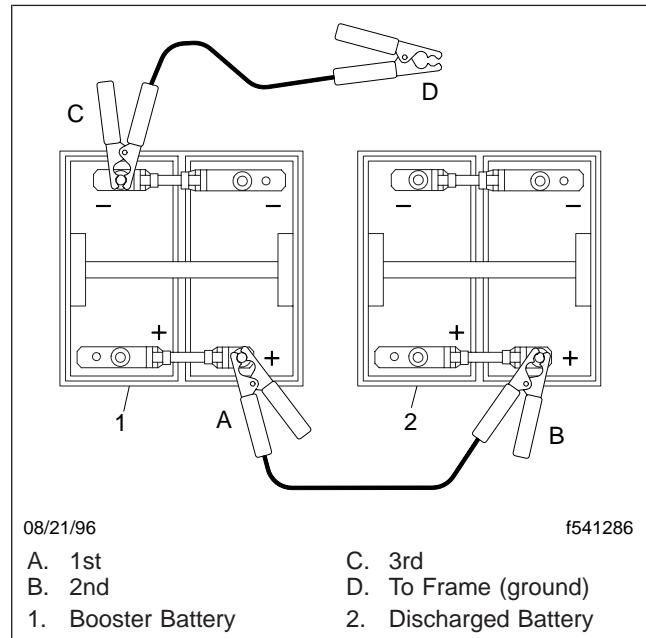

Fig. 8.1, Jumper Connections

### WARNING

Do the next step exactly as instructed and do not allow the clamps of one cable to touch the clamps of the other cable. Otherwise, a spark could occur near a battery, possibly resulting in severe personal injury from explosion and acid burns.

3. Connect one end of the second jumper cable to the negative terminal of the booster battery and connect the other end of the cable to a ground at least 12 inches (300 mm) away from the batteries of the vehicle needing the start. The vehicle frame is usually a good ground. Do *not* connect the cable to or near the discharged batteries.
4. Start the engine of the vehicle with the booster batteries and let the engine run for a few minutes to charge the batteries of the other vehicle.

## CAUTION

Don't crank the engine for more than 30 seconds at a time during any of the following procedures. Wait two minutes after each try to allow the starter to cool. Failure to do so could cause starter damage.

5. Attempt to start the engine of the vehicle with the batteries receiving the charge.
6. When the engine starts, let it idle for a few minutes.

## WARNING

Do the next step exactly as instructed and do not allow the clamps of one cable to touch the clamps of the other cable. Otherwise, a spark could occur near a battery, possibly resulting in severe personal injury from explosion and acid burns.

7. Disconnect the grounded (negative) cable from the frame or other non-battery location; then disconnect the other (negative) end of the cable.
8. Disconnect the remaining (positive) cable from the newly charged battery first; then disconnect the other (positive) end.

## Changing a Flat Tire

### WARNING

This vehicle is very heavy. Jacking this vehicle should be done with extreme caution. The vehicle could slip, causing personal injury or death.

### WARNING

Wheel lug nut torque is very high and the wheel/tire assemblies are very heavy. Changing a tire could result in back injury. If possible, call a qualified service facility to change a flat tire.

IMPORTANT: If a flat tire occurs while driving, gradually decrease vehicle speed. Holding the steering wheel firmly, move to a safe place on the side of the road.

1. If possible, stop the vehicle on a level surface, away from traffic.
2. Set the parking brake and turn the ignition switch to the OFF position.
3. Turn on the emergency flashers.
4. Remove the spare wheel, jack, jack handle, and lug wrench from storage, if so equipped.
5. Use a block to chock the wheel diagonally opposite the wheel being changed.

NOTE: The jacking point for the front and rear wheels is directly under the axle.

6. Place the jack on a solid surface. Insert the jack handle and pump the handle to slightly raise the vehicle. *Do not raise the wheel off of the ground.* Loosen the wheel lug nuts, but do not remove them.

NOTE: On VCL chassis vehicles only, the dual rear wheels are attached using two-element lug nuts. The larger nut retains the outer dual. The inner square stud retains the inner dual. Remove and install these nuts separately. The rear dual outer lug nut must be loosened to check and retighten the inner nut.

7. Raise the vehicle until the wheel is off of the ground. Remove the lug nuts and the wheel.
8. Install the spare wheel and the lug nuts. Make sure that the beveled sides of the nuts face inward.
9. In a star pattern, tighten the nuts evenly until snug.
10. Lower the vehicle until the wheel touches the ground. Tighten the wheel nuts to the correct torque specifications in the proper tightening sequences. See **Group 40** of the *Recreational Vehicle Chassis Maintenance Manual* for instructions.
11. Finish lowering the vehicle to the ground, then remove the jack.
12. Remove the wheel chock (the block), then stow the jack, jack handle, and lug wrench.
13. After operating the vehicle for 50 to 100 miles (80 to 160 km), retighten the nuts. Tighten the wheel nuts to the correct torque specifications in

# In an Emergency

---

the proper tightening sequences. See **Group 40** of the *Recreational Vehicle Chassis Maintenance Manual* for instructions.

## Running Out of Fuel

 **WARNING**

Diesel fuel is highly flammable. When you approach a vehicle and the smell of diesel fuel is present, immediately shut off all engines and ignition sources. Avoid causing sparks and stay away from arcing switches and equipment. Extinguish cigarettes, pilot lights, flames, or other sources of ignition in the area and adjacent areas. Immediately provide extra ventilation to the area. Do not start the vehicle or any other type of equipment until the fuel leak is corrected and the area cleared of fuel. Failure to perform these actions could lead to the ignition of the fuel, which could cause personal injury or death, or severe property damage.

If your vehicle runs out of fuel, stop the vehicle on a level location away from traffic. The engine may be restarted by adding at least two gallons (eight liters) of fuel to the fuel tank. If the vehicle is not level, up to six gallons (22 liters) of fuel may be required. Prolonged engine cranking may be required to pump fuel from the fuel tank to the engine before the engine will start.

 **CAUTION**

**Do not crank the engine for more than 30 seconds at a time during any of the following procedures. Wait two minutes after each try to allow the starter to cool. Failure to do so could cause starter damage.**

If your vehicle will not start by cranking the engine, the fuel system may need to be primed. See the *Caterpillar, Cummins, or the Mercedes-Benz Operation and Maintenance Manual*.

# 9

## Specifications

---

Fluids and Lubricants .....	9.1
Fuse/Relay/Circuit Breaker Identification .....	9.1
Electric Service Center .....	9.1



# Specifications

## Fluids and Lubricants

See [Table 9.1](#) for fluid and lubricant specifications.

Fluid and Lubricant Specifications	
Component	Recommended Fluid or Lubricant
Front Axle Spindle Pins, Tie Rods, Drag Link, Intermediate Steering Shaft, Front Brake Pedal Shafts, Slip Spline and Universal Joints	Multipurpose Grease Lithium 12 Hydroxy Stearate NLGI No. 2; for temperatures below 0°F (-18°C), use MIL-G-10924B
Hydraulic Steering System Reservoir	Dexron® III ATF
Engine Oil *	See Below
Allison Transmission Fluid.	TranSynd Synthetic ATF
Fuel	Grade No. 2-0 or 2-D
Front Axle Wheel Bearings	Hypoid Gear Oil SAE 80-90
Rear Axle Differential	
Engine Coolant	50% Water/50% Ethylene Glycol Antifreeze (with approved SCAs)
Hydraulic Brake Reservoir	Heavy-Duty DOT 3 Brake Fluid
Auto-Apply Park Brake Reservoir	Dexron® III ATF

\* See the *Caterpillar* or the *Cummins Operation and Maintenance Manual* for engine oil specifications.

**Table 9.1, Fluid and Lubricant Specifications**

## Fuse/Relay/Circuit Breaker Identification

Circuit breakers protect against circuit overload. If a circuit becomes overloaded (usually caused by a short to ground), the circuit breaker opens, stopping current flow. The vehicle may be equipped with auto-reset breakers.

## Fuse/Relay/Circuit Breaker Identification (front-engine diesel chassis)

The electrical system has four separate power distribution modules (PDMs) containing both fuses and relays. An optional tow power PDM is also available. The PDMs are mounted in two places:

- Two in the cab area left of the steering wheel
- Two (or three including the optional tow power PDM) on the exterior side of the operator's station

See [Fig. 9.1](#) and [Fig. 9.2](#).

## Fuse/Relay/Circuit Breaker Identification

The electrical system has two separate boxes containing both fuses and relays. The boxes are mounted in one of three locations:

- on the exterior frontwall of the driver's area
- on the interior frontwall under the dash
- on a side panel in the driver's area

Box 1 and box 2 are mounted approximately 6 inches (15 cm) apart. See [Fig. 9.3](#) and [Fig. 9.4](#).

## Electric Service Center

On "new VCL" (tag axle) chassis models, several electrical components (and fuel and hydraulic filters) are consolidated in one area in an electric service center. The service center is located at the rear of the vehicle on the right side. See [Fig. 9.5](#).

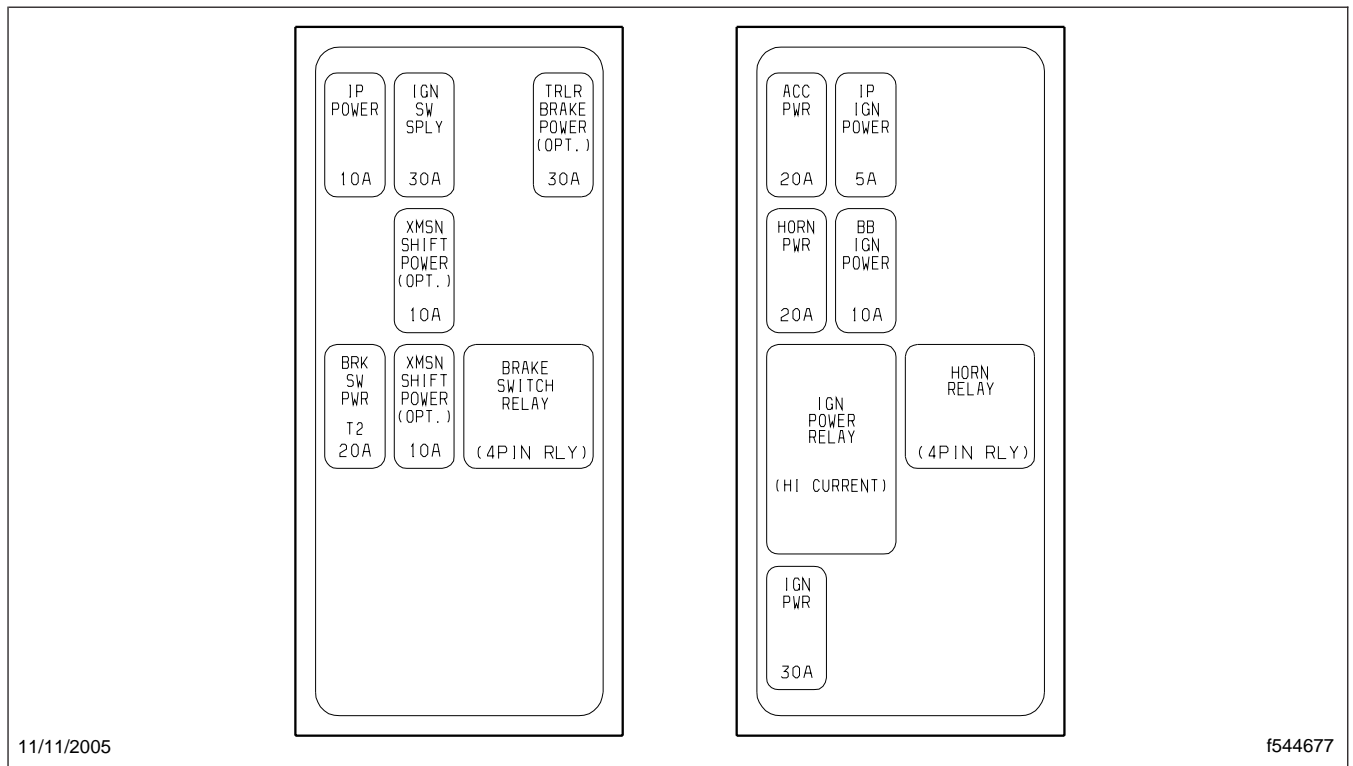

11/11/2005

f544677

**Fig. 9.1, Cab PDMs**

# Specifications

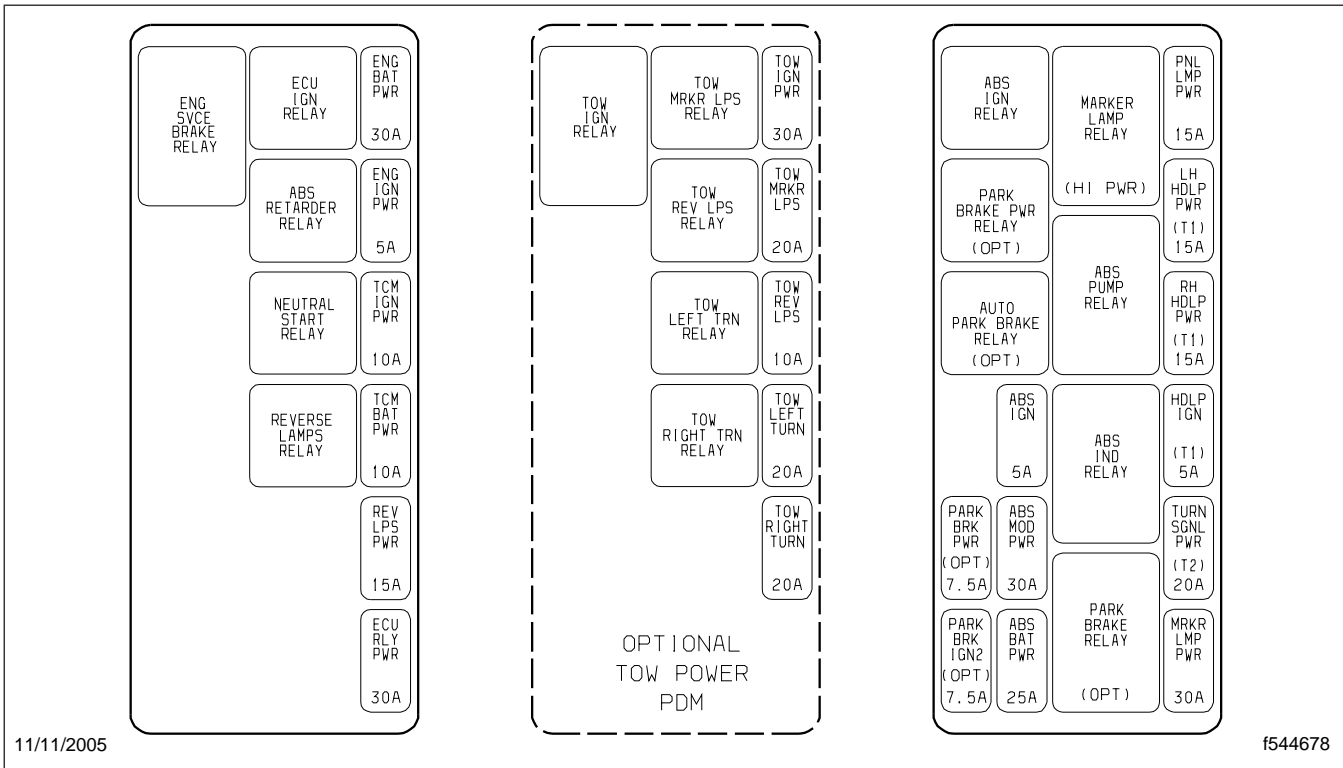
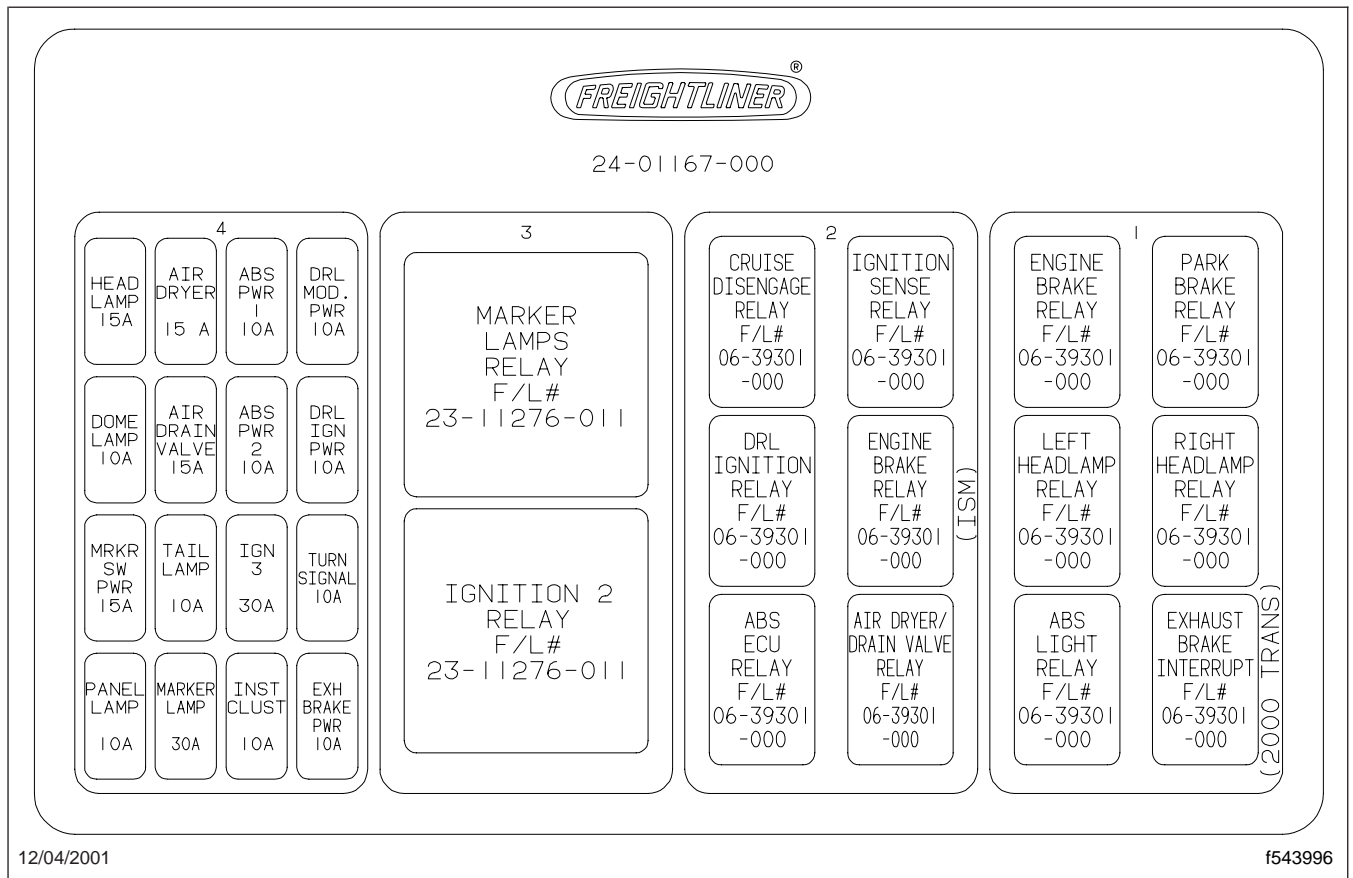
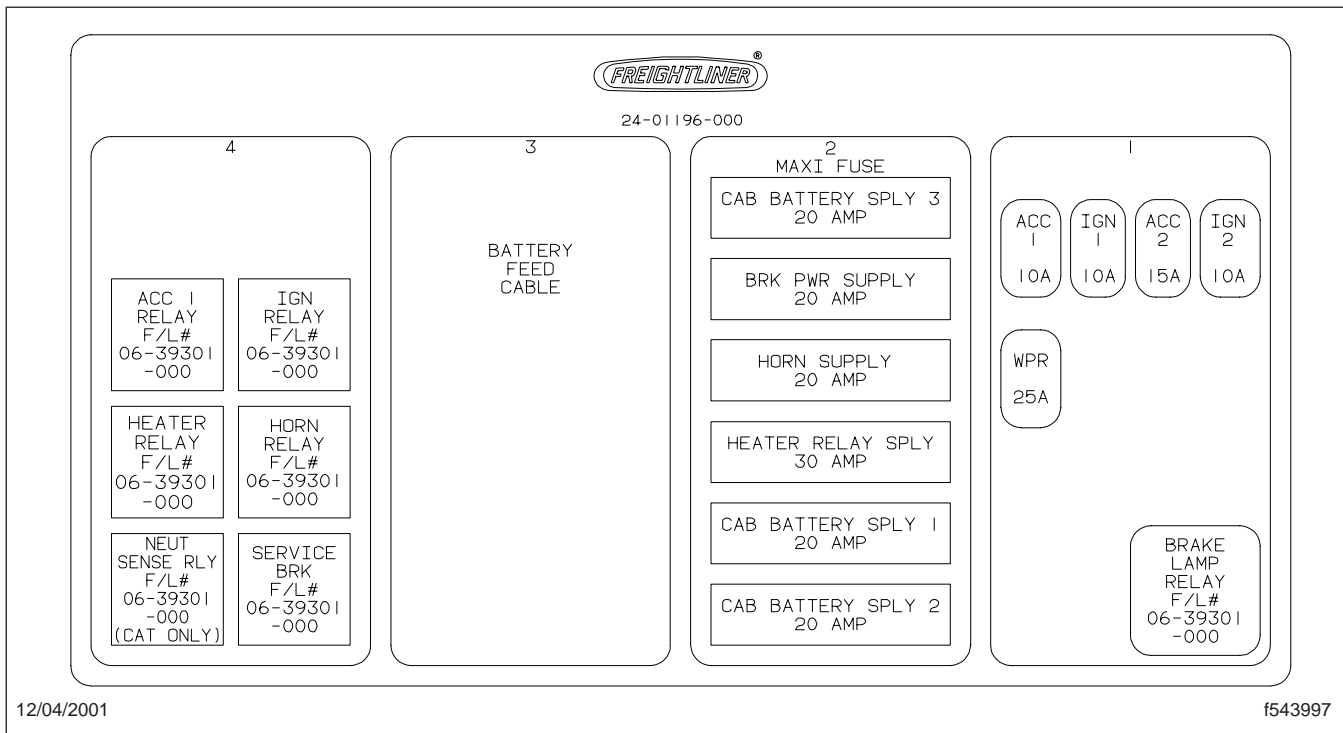

Fig. 9.2, Chassis and Optional Tow Power PDMs

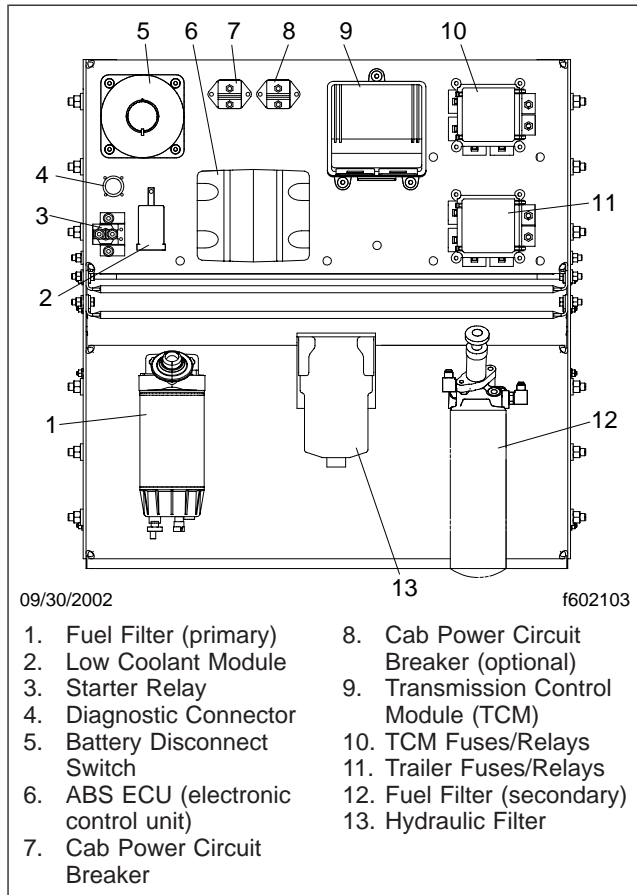

**Fig. 9.3, Fuse/Relay Box 1**

# Specifications



**Fig. 9.4, Fuse/Relay Box 2**



**Fig. 9.5, Electric Service Center**

# 10

## Towing

---

Towing the Vehicle .....	10.1
Towing With the Vehicle .....	10.2



# Towing

## Towing the Vehicle

**IMPORTANT:** When it is necessary to tow the vehicle, follow the instructions below closely to prevent damage to the vehicle.

On vehicles equipped with an independent front suspension, do not tow the vehicle by the suspension assembly. Components of the suspension can be damaged.

When towing or pushing any vehicle equipped with an Allison transmission, disconnect the driveshaft at the rear axle and support it as necessary, regardless of the distance or speed traveled.

## Removing the Transmission from the Park (P) Position

If a vehicle with a shift-by-wire (SBW) system needs to be towed and the system cannot be activated to take the transmission out of Park (P), follow the steps in the procedure below.

### **WARNING**

**Due to the many variables that exist in towing, positioning the lifting and towing device is the sole responsibility of the tow vehicle operator. The operator must be familiar with standard towing industry safety measures. Improper procedures could result in personal injury or death.**

1. Set the parking brake on the tow vehicle.
2. Chock the tires of the tow vehicle.
3. Set the parking brake on the disabled vehicle.
4. Chock the tires of the disabled vehicle.
5. Underneath the disabled vehicle, at the transmission, remove the access hole plug at the rear of the SBW actuator. See [Fig. 10.1](#).
6. Insert a 3/16-inch allen wrench or hex key through the access hole into the rear of the actuator. Turn the allen wrench in a clockwise direction until the transmission comes out of the Park (P) position.
7. Replace the access hole plug.

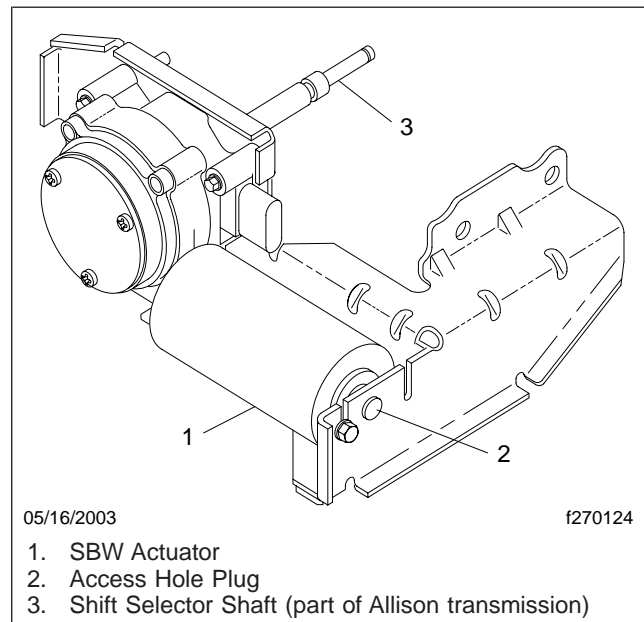

**Fig. 10.1, SBW Actuator (at transmission)**

8. Remove the chocks from the tires of both vehicles.

**NOTE:** The transmission may also be placed in the Park (P) position using this procedure.

## Front Towing Hookup

1. Disconnect the battery ground cable.
2. If the vehicle is to be lifted and towed, remove the driveshaft.

### **CAUTION**

**Failure to remove the driveshaft when towing the vehicle with the rear wheels on the ground could result in damage to the transmission and other parts.**

### **WARNING**

**Due to the many variables that exist in towing, positioning the lifting and towing device is the sole responsibility of the tow vehicle operator. The operator must be familiar with standard towing industry safety measures. Improper procedures could result in personal injury or death.**

3. Attach the towing device.

4. Lift the vehicle and secure the safety towing chains. If additional clearance is needed, remove the front wheels.
5. Connect the clearance lights, taillights, and signal lights. Connect any special towing lights required by local regulations.

## WARNING

Before releasing the parking brakes, make the connection to the towing vehicle or chock the tires on the disabled vehicle. Failure to do so could result in hazardous conditions because the vehicle could suddenly roll and injury could occur.

6. Release the parking brake.

## CAUTION

Before attempting to tow a vehicle with air suspension (and during the towing operation), ensure that the air suspension is properly aired. Air the suspension through the Schrader valve on the air dryer. Attempting to tow a vehicle with an improperly aired suspension may result in damage to the chassis and body.

### Rear Towing Hookup

1. Position the front tires so that they point straight ahead and secure the steering wheel in this position.
2. Disconnect the battery ground cable.

## WARNING

Due to the many variables that exist in towing, positioning the lifting and towing device is the sole responsibility of the tow vehicle operator. The operator must be familiar with standard towing industry safety measures. Improper procedures could result in personal injury or death.

3. Attach the towing device.
4. Lift the vehicle and secure the safety towing chains. If additional clearance is needed, remove the bumper extension, if so equipped.

5. Connect the clearance lights, taillights, and signal lights. Also connect any special towing lights required by local regulations.

## CAUTION

Before attempting to tow a vehicle with air suspension (and during the towing operation), ensure that the air suspension is properly aired. Air the suspension through the Schrader valve on the air dryer. Attempting to tow a vehicle with an improperly aired suspension may result in damage to the chassis and body.

### Towing With the Vehicle

## WARNING

Freightliner neither recommends nor approves connecting a trailer or other towed vehicle's braking system directly to the vehicle braking system. Freightliner LLC also neither recommends nor approves tapping into the vehicle air brake system, nor operating a towed vehicle or trailer's braking system by means of the vehicle braking system. Failure to observe this warning could result in severe injury or death, or substantial property damage.

Do not tow unbraked vehicles if the combined weight of both vehicles is more than the sum of the gross axle weight ratings (GAWR) of the towing vehicle. Otherwise brake capacity will be inadequate, which could result in personal injury or death.

### General Information

**IMPORTANT:** An auxiliary braking system is strongly recommended when towing. Follow your state's motor vehicle regulations and the body builder's recommendations to determine if an auxiliary system is required for towing.

Towing a load puts an additional strain on your vehicle's engine, drivetrain, brakes, tires, and suspension. For your safety and the care of your vehicle, properly match the towed load to the vehicle as follows:

1. Never load the vehicle over the Gross Vehicle Weight Rating (GVWR). Considerable damage to

# Towing

the drivetrain may result if the vehicle is over its GVWR. Check the GVWR safety compliance certification label (provided by the final manufacturer) to find the GVWR.

2. Use the Gross Combined Weight Rating (GCWR) and Gross Vehicle Weight (GVW) to determine the towing capacity. Refer to the final manufacturer for GCWR. If the GCWR is exceeded, serious damage to the drivetrain and brake system may result. Loading past the GCWR may lead to unsafe operating and braking conditions.
3. Subtract the GVW (which is the actual weight of the vehicle alone) from the GCWR (which is the total weight this vehicle can safely pull) to determine the acceptable weight this vehicle can tow.
4. Make sure that the towing equipment is properly and safely attached to your vehicle.
5. When descending a steep grade, shift the transmission into the next lower gear or use the exhaust brake to provide additional engine braking.

**NOTE:** In a high-altitude operating environment, your engine will lose power at the rate of 1 percent per 1000 feet (305 meters) of elevation. For these high-altitude operating conditions, a reduction in gross vehicle weights and gross combination weights is recommended and will result in improved vehicle performance.

6. To avoid vehicle damage and handling difficulty, evenly distribute the trailer load. Always tie the load down securely.

## 7-Pin Connector

The following information lists the amperage (amp) load limits for each of the connections in the 7-pin connector. See **Fig. 10.2** for an example of the 7-pin connector.

- Electric Brakes (to brake the system) — A 12 gauge wire interfaces with the 7-pin connector trailer tow plug. See the brake manual for exact specifications.
- RH Stop/Turn — 20 amp
- Back Up Lamps — 10 amp
- LH Stop/Turn — 20 amp
- Running Lamps — 20 amp

- Ignition [+] (to charge the tow vehicle batteries) — 40 amp
- Ground [-] — for all

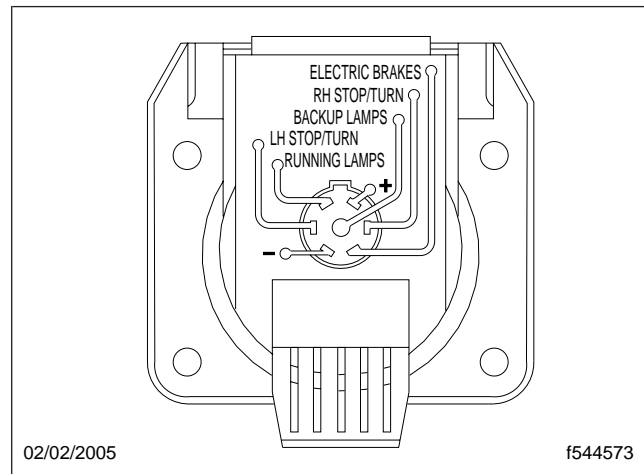

**Fig. 10.2, 7-Pin Connector**

## Hitches

Use a hitch and ball recommended by your vehicle manufacturer or your dealer and make sure that its location is compatible with that of the trailer. Use a good weight-carrying hitch that uniformly distributes the trailer tongue loads through the bumper and the frame. Do not exceed the recommended towing capacity of the vehicle.

### **CAUTION**

**Always disconnect the battery and the engine ECM (electronic control module) before welding anything to the chassis frame.**

**Do not use single-clamp bumper hitches or hitches that attach to the vehicle axle. However, multi-clamp bumper hitches for occasional use of a rental trailer are acceptable if properly attached. Follow the towing instructions of a reputable rental agency. Never attach safety chains to the bumper.**

Whenever a trailer hitch is removed, be sure to have all mounting holes in the underbody properly sealed to prevent possible entry of exhaust fumes, dirt, or water.

## Trailers



**Always use safety chains between the vehicle and the trailer. Failure to do so could cause personal injury or death if the hitch fails.**

**IMPORTANT:** Before connecting a trailer lighting system directly to the lighting system of the vehicle, see your dealer or rental trailer agency for the correct type of wiring and relays for your trailer and for heavy-duty flashers.

### Parking With A Trailer

Park the vehicle on a flat surface. Chock the tires as follows:

1. Select Neutral (N) on the gear shift selector while depressing the service brake.
2. Continue depressing the service brake and have another person place wheel chocks under the trailer wheels.
3. Once the wheel chocks are in place, release the service brake, making sure that the chocks are holding the vehicle and trailer.

### Trailer Towing Tips

Towing a trailer significantly alters the manner in which the towing vehicle performs.

- Before starting on a trip, practice turning, stopping, and backing in an area away from heavy traffic to gain experience in handling the extra weight and length of the trailer. Take enough time to learn the "feel" of the vehicle/trailer combination before starting out on a trip.
- Skillful backing requires practice. Back very slowly, with someone outside at the rear of the trailer to guide your efforts. Place your hand at the bottom of the steering wheel and move it in the direction you want the rear of the trailer to swing. Make small corrections instead of exaggerated ones. A slight movement of the steering wheel will result in a much larger movement of the rear of the trailer.
- Allow considerably more room for stopping when the trailer is attached. If you have a manual brake controller, "lead" with the trailer

brakes (if so equipped) when approaching a stop, if possible. Trailer brakes are also handy for correcting trailer side-sway. Just touch them for a moment without using your vehicle brakes and the trailer should settle down and track steadily again.

- To assist in attaining good handling of the vehicle trailer combination, it is important that the trailer tongue load be maintained at approximately 10 to 15 percent of the loaded trailer weight.
- Check everything before starting out on the road. After you have traveled about 50 miles (80 km), stop in a protected location and double-check your trailer hitch and electrical connections for security. Also, examine the trailer wheel lug nuts for tightness.
- Because trailer wheels will be closer than the towing vehicle wheels to the inside of the turn, drive slightly beyond the normal turning point.
- Allow extra distance for passing other vehicles. Downshift to a lower gear for better acceleration, if necessary.
- Ahead of the vehicle, allow at least the equivalent of one vehicle and trailer length combined for each 10 mph (16 km/h) of speed.
- If your vehicle begins to lose speed as you climb a hill, downshift to a lower gear for more power at the rear wheels.
- Before descending a steep grade, slow down and shift to a lower gear. Driving with the transmission in a lower gear will assist in reducing downhill speed. If the trailer should begin to sway, touch the trailer brakes (if so equipped), not the vehicle brakes, and the trailer should settle down.

# Index

---

Subject	Page
<b>A</b>	
Air Brake System	6.1
Automatic Slack Adjusters	6.2
Brake Burnishing (new vehicle)	6.2
General Information	6.1
Operation	6.1
Allison Automatic Transmissions	4.1
1000/2000/2000 MH Models	4.1
1000/2000/2100/2400 Models (Arens SBW)	4.2
3000 MH/4000 MH/4000 MHP Models	4.1
Antilock Braking System (ABS)	6.3
Meritor WABCO® Antilock Braking System (ABS)	6.3
<b>C</b>	
Changing a Flat Tire	8.2
Cold Weather Operation	3.3
Caterpillar	3.3
Cummins	3.3
Mercedes-Benz	3.3
Controls	2.1
After-Treatment System (ATS) Regen Connector	2.7
Allison Automatic Transmissions	2.4
Backup Alarm (optional)	2.7
Cruise Control System	2.5
Electric Horn	2.7
Hazard Warning Lights (models built before July 2002)	2.3
Hazard Warning Lights (models built from July 2002, on)	2.3
Headlight Switches and Panel Lights (models built before August 2003)	2.2
Headlight Switches and Panel Lights (models built from August 2003, on)	2.1
Ignition Switch and Key	2.1
Interrupt Switch (optional)	2.2
Parking Brake Controls	2.2
Tag Axle Suspension Dump Switch (optional)	2.6
Tilt/Telescope Steering Column	2.7
Turn Signal Lever	2.3
VCL Chassis Dash Switches	2.7

Subject	Page
Cruise Control	3.5
SmartWheel Cruise Control	3.7
<b>E</b>	
Electric Service Center	9.1
Emergency Starting With Jumper Cables	8.1
Engine Braking (optional)	3.9
Compression (Engine) Brake	3.9
Exhaust Brake	3.9
Mercedes-Benz	3.10
Engine Operation	3.3
Caterpillar	3.4
Cummins	3.4
Mercedes-Benz	3.5
Engine Shutdown	3.7
Caterpillar	3.7
Cummins	3.8
Mercedes-Benz	3.8
Engine Starting	3.2
Caterpillar	3.2
Cummins	3.2
Mercedes-Benz	3.3
EPA07 After-Treatment System (ATS)	3.1
EPA07 Exhaust Emissions	1.1
<b>F</b>	
Fluids and Lubricants	9.1
Freightliner Help	8.1
Fuse/Relay/Circuit Breaker Identification	9.1
Fuse/Relay/Circuit Breaker Identification (front-engine diesel chassis)	9.1
Fuse/Relay/Circuit Breaker Identification	9.1
<b>H</b>	
Hazard Warning Lights	8.1
High Altitude Operation	3.9
Hydraulic Brake System (front-engine diesel chassis)	6.4
Auto-Apply Parking Brake Operation	6.5
General Information	6.4
Meritor WABCO® Antilock Braking System (ABS), Hydraulic Brake Systems	6.4
Operation	6.5

Subject	Page	Subject	Page
<b>I</b>			
Instrument Panel	2.1	SmartWheel (optional)	2.7
Instrumentation Control Unit (front-engine diesel chassis)	2.28	Headlamp Interrupt	2.7
Dash Message Center	2.28	Horn	2.7
Ignition Sequence	2.29	Marker Lamp Interrupt	2.8
Mode/Reset Switch	2.31	Windshield Wipers	2.8
Odometer	2.31	<b>T</b>	
Instruments	2.10	Tilt/Telescope Steering Column	5.1
Air Pressure Gauges	2.13	Douglas Column	5.1
Coolant Temperature Gauge	2.11	TRW Column	5.1
Engine Oil Pressure Gauge	2.11	Towing the Vehicle	10.1
Fuel Gauge	2.12	Front Towing Hookup	10.1
Intake-Air Restriction Indicator	2.13	Rear Towing Hookup	10.2
Speedometer	2.10	Removing the Transmission from the Park (P) Position	10.1
Tachometer	2.12	Towing With the Vehicle	10.2
Transmission Temperature Gauge (optional)	2.12	7-Pin Connector	10.3
Voltmeter	2.11	General Information	10.2
<b>L</b>			
Light Bar Control Unit (LBCU)	2.14	Hitches	10.3
Audible Alarms	2.18	Trailers	10.4
Emergency Shutdown	2.19	Towing	8.1
Gauges	2.14	<b>V</b>	
Information Center	2.19	Vehicle Identification Number (VIN)	1.1
Menu Structure	2.20	Vehicle Specification Label	1.1
Warning and Indicator Lights	2.14	<b>W</b>	
<b>M</b>			
Multiple Module Data Computer (MMDC)	2.20	Warning and Indicator Lights	2.9
Annunciator Module	2.20	Antilock Braking System (ABS)	2.10
Audible Alarms	2.24		
Gauges	2.21		
Information Center	2.25		
Menu Structure Road Map	2.28		
<b>P</b>			
Power Steering System	5.1		
Pretrip Inspection and Daily Maintenance Procedures	7.1		
Pretrip Inspection Checklist	7.1		
<b>R</b>			
Running Out of Fuel	8.3		