

Smart choice for power

xantrex

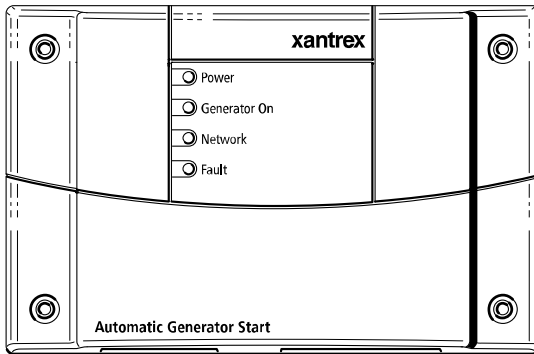

Owner's Guide

Automatic Generator Start



www.xantrex.com

Automatic Generator Start

Owner's Guide

About Xantrex

Xantrex Technology Inc. is a world-leading supplier of advanced power electronics and controls with products from 50 watt mobile units to one MW utility-scale systems for wind, solar, batteries, fuel cells, microturbines, and backup power applications in both grid-connected and stand-alone systems. Xantrex products include inverters, battery chargers, programmable power supplies, and variable speed drives that convert, supply, control, clean, and distribute electrical power.

Trademarks

Automatic Generator Start is a trademark of Xantrex International. Xantrex and Xanbus are registered trademarks of Xantrex International.

Other trademarks, registered trademarks, and product names are the property of their respective owners and are used herein for identification purposes only.

Notice of Copyright

Automatic Generator Start Owner's Guide © November 2004 Xantrex International. All rights reserved.

Disclaimer

UNLESS SPECIFICALLY AGREED TO IN WRITING, XANTREX TECHNOLOGY INC.
("XANTREX")

(a) MAKES NO WARRANTY AS TO THE ACCURACY, SUFFICIENCY OR SUITABILITY OF ANY TECHNICAL OR OTHER INFORMATION PROVIDED IN ITS MANUALS OR OTHER DOCUMENTATION.

(b) ASSUMES NO RESPONSIBILITY OR LIABILITY FOR LOSS OR DAMAGE, WHETHER DIRECT, INDIRECT, CONSEQUENTIAL OR INCIDENTAL, WHICH MIGHT ARISE OUT OF THE USE OF SUCH INFORMATION. THE USE OF ANY SUCH INFORMATION WILL BE ENTIRELY AT THE USER'S RISK.

Date and Revision

November 2004 Revision C

Part Number

975-0082-01-01

Contact Information

Telephone: 1 800 670 0707 (toll free North America)
1 360 925 5097 (direct)

Fax: 1 800 994 7828 (toll free North America)
1 360 925 5143 (direct)

Email: customerservice@xantrex.com

Web: www.xantrex.com

About This Guide

Purpose

The purpose of this Owner's Guide is to provide explanations and procedures for installing, operating, maintaining, and troubleshooting the Automatic Generator Start.

Scope

The Guide provides safety guidelines, detailed planning and setup information, procedures for installing the Automatic Generator Start, as well as information about configuring, operating and troubleshooting the unit. This guide does not provide information about choosing a generator or operating a generator.

Firmware Revision

The information in this manual applies to firmware revision 1.03.00. Some Auto Gen Start features and functions described in this manual may be incompatible with earlier firmware revisions. To view the firmware revision number of your product, see page 4–8.

Audience

The Guide is intended for anyone who needs to install and/or operate the Automatic Generator Start. Installers should be certified technicians or electricians.

Organization

This Guide is organized into five chapters and three appendixes.

Chapter 1, “Introduction”, introduces and describes features of the Automatic Generator Start.

Chapter 2, “Installation”, contains planning information and procedures to install the Automatic Generator Start.

Chapter 3, “Configuration”, provides information and procedures for configuring the Automatic Generator Start.

Chapter 4, “Operation”, describes common tasks you may need to perform with the Automatic Generator Start.

Chapter 5, “Troubleshooting”, contains information and procedures to troubleshoot the Automatic Generator Start.

Appendix A, “Specifications”, contains the electrical, mechanical, and environmental specifications for the Automatic Generator Start.

Appendix B, “Generator Auto Start Requirements and Types”, provides general information about generators that will work with the Automatic Generator Start.

Appendix C, “Relay Timing”, contains information about relay configuration and timing for each basic type of Auto Gen Start starting mode.

“Warranty and Return Information” contains the warranty for your Automatic Generator Start as well as instructions for returning the product for servicing.

Conventions Used

The following conventions are used in this guide.



WARNING

Warnings identify conditions or practices that could result in personal injury or loss of life



CAUTION

Cautions identify conditions or practices that could result in damage to the unit or other equipment.

Important: These notes contain information that is important for you to know, but is not as critical as a caution or warning.

Abbreviations and Acronyms

Auto Gen Start, AGS	Abbreviations for the Automatic Generator Start used in this manual and on the Control Panel.
DC V	DC voltage—usually refers to battery voltage
SOC	State of charge—refers to a percentage of a battery's remaining capacity.

Related Information

For more information about related products, refer to:

Xanbus System Installation Guide (975-0136-01-01)

Inverter/Charger Installation Guide (975-0126-01-01)

Inverter/Charger Operation Guide (975-0125-01-01)

System Control Panel Owner's Guide (975-0083-01-01)

These guides are available at www.xantrex.com, where you can find more information about Xantrex Technology Inc. and its products and services.

Important Safety Instructions



WARNING: Save these instructions

This Owner's Guide contains important safety and operating instructions. Before using your Automatic Generator Start, be sure to read, understand, and save these safety instructions.



WARNING: Restrictions on use

The Automatic Generator Start shall not be used in connection with life support systems or other medical equipment or devices.



WARNING: Safety hazard

Disable the Automatic Generator Start if the generator or vehicle equipped with the generator is in an enclosed building or area where the generator exhaust is not vented to the outside.

General Precautions

1. Before installing and using the Auto Gen Start, read all appropriate sections of this guide.
2. If the Auto Gen Start is inoperative, see "Warranty and Product Information" on page WA-1.
3. Do not dismantle the Auto Gen Start; it contains no user serviceable parts. See "Information About Your System" on page WA-5 for instructions on obtaining service.
4. Protect the Auto Gen Start from rain, snow, spray, and water.
5. Disable the generator's starting circuit by disconnecting the starter battery, spark plug, et cetera, before wiring this device.
6. To reduce the risk of electrical shock, put the Xantrex Xanbus system into Safe mode before working on any circuits connected to it. See "Safe mode" on page 4-7.
7. Disable the automatic starting circuit and/or disconnect the generator from its starting battery to prevent accidental starting while performing maintenance.

Explosive Gas Precautions



WARNING: Explosion hazard

This equipment is not ignition protected. To prevent fire or explosion, do not install the Auto Gen Start in compartments containing flammable materials or in locations that require ignition-protected equipment. This includes any space containing gasoline-powered machinery, fuel tanks, as well as joints, fittings, or other connections between components of the fuel system.

Be sure you follow all relevant instructions exactly before installing or using your Auto Gen Start.

FCC Information to the User

This equipment has been tested and found to comply with the limits for a Class B digital device, pursuant to part 15 of the FCC Rules. These limits are designed to provide reasonable protection against harmful interference when the equipment is operated in a residential environment. This equipment generates, uses and can radiate radio frequency energy and, if not installed and used in accordance with the instruction guide, may cause harmful interference to radio communications. However, there is no guarantee that interference will not occur in a particular installation. If this equipment does cause harmful interference to radio or television reception, which can be determined by turning the equipment off and on, the user is encouraged to try to correct the interference by one or more of the following measures:

- Reorient or relocate the receiving antenna.
- Increase the separation between the equipment and the receiver.
- Connect the equipment into an outlet on a circuit different from that to which the receiver is connected.
- Consult the dealer or an experienced radio/TV technician for help.

Contents

Important Safety Instructions	-vii
--	------

1 Introduction

About the Automatic Generator Start	1-2
Features	1-3
System Requirements	1-4
Front and Bottom Panel	1-5
Front panel	1-5
Bottom panel	1-6
Xanbus System Components	1-7

2 Installation

Preparing an Installation	2-2
Tools and materials required	2-2
Choosing a location	2-3
Routing the connections	2-3
Installing the Auto Gen Start	2-4
Mounting the unit	2-5
Wiring to the 20-contact connector	2-6
Connecting the generator	2-9
Type 1	2-10
Type 2	2-11
Type 3	2-12
Type 4	2-13
Type 5	2-14
Type 6	2-15
Type 7	2-15
Type 8	2-17
Type 9	2-18
Type 10	2-19
Type 11	2-20
Type 12	2-21
Type 13	2-22

- Connecting the thermostats (optional) ----- 2-23
- Connecting an external shutdown (optional) ----- 2-23
- Connecting an external manual on/off switch (optional) ----- 2-23
 - Connecting an external on/off LED ----- 2-24
- Connecting the wiring harness to the Auto Gen Start ----- 2-25
- Connecting the control panel and other network-enabled devices ----- 2-26
- Verifying power is available ----- 2-26

3 Configuration

- Configuring the Auto Gen Start ----- 3-2
 - Using the System Control Panel ----- 3-2
 - Changing Auto Gen Start settings using the System Control Panel ----- 3-3
 - Viewing the Select Device menu ----- 3-3
 - Viewing the Auto Gen Start menu ----- 3-4
 - Selecting and adjusting the changeable setting ----- 3-4
- The Auto Gen Start Menu ----- 3-5
 - The Auto Gen Start basic menu ----- 3-7
 - Gen Status ----- 3-8
 - Gen Trigger ----- 3-8
 - AGS Mode ----- 3-9
 - QT Enable ----- 3-11
 - QT Begin ----- 3-11
 - QT End ----- 3-13
 - Start SOC ----- 3-13
 - Start DCV ----- 3-14
 - Enable Temp1 ----- 3-15
 - Enable Temp2 ----- 3-16
 - Gen Type ----- 3-16
 - Clear Faults ----- 3-17
 - Auto Gen Start advanced menu ----- 3-18
 - Configure Triggers ----- 3-18
 - Configure Gen ----- 3-18
 - View Device Info ----- 3-18
 - Basic Menu ----- 3-18
 - AGS Triggers menu ----- 3-19
 - Start SOC ----- 3-19
 - Stop SOC ----- 3-19
 - StartV:30sec ----- 3-20
 - StartV:15min ----- 3-20

StartV:2hr	3-21
StartV:24hr	3-22
StopBattV	3-22
Enable Temp1	3-23
Enable Temp2	3-23
Enable Load	3-23
Start Load	3-24
Stop Load	3-25
Stop Absorb	3-25
Stop Float	3-26
Generator Configuration menu	3-28
Starter Cool Down	3-28
Max Run Time	3-29
Exercise Per	3-29
Exercise Dur	3-30
Exercise Time	3-31
Relay3	3-31
Run Hold Time	3-32
Crank Time	3-32
Crank Retry Time	3-33
Preheat Time	3-33
Start Tries	3-34
AGS: Device Info menu	3-35
View Fault Log	3-35
View Warning Log	3-35
View Event Log	3-35
Restore Defaults	3-35
User Settings	3-36

4 Operation

Starting and Stopping the Generator	4-2
Setting Quiet Time	4-3
Enabling Quiet Time	4-3
Setting the beginning of Quiet Time	4-3
Setting the end of Quiet Time	4-4
Viewing the Advanced Menu	4-5
Changing System Modes	4-6
Operating mode	4-7
Power Save mode	4-7

Safe mode ----- 4-7
Hibernate mode ----- 4-8
Viewing the Firmware Revision Number ----- 4-8

5 Troubleshooting

Faults and Warnings ----- 5-2
Warning Messages ----- 5-3
Fault Messages ----- 5-5

A Specifications

Electrical Specifications ----- A-2
Mechanical Specifications ----- A-2
Environmental Specifications ----- A-3
Regulatory Compliance ----- A-3

B Generator Auto Start Requirements and Types

Recommended Features ----- B-2
Generator Starting Types ----- B-2
 Two wire ----- B-3
 Identification ----- B-3
 Connection ----- B-3
 Three-Wire Onan ----- B-3
 Identification ----- B-3
 Connection ----- B-4
 Three-Wire Automotive ----- B-4
 Identification ----- B-4
 Connection ----- B-4

C Relay Timing

RunMode ----- C-2
MomentaryRun Mode ----- C-3
GlowStop Mode ----- C-4
StartStop Mode ----- C-4
PulseStop Mode ----- C-5

Warranty and Return Information ----- WA-1

Index ----- IX-1

1

Introduction

Chapter 1 describes the main features of the Automatic Generator Start. It also describes the Xanbus System of which the Auto Gen Start is a component.

About the Automatic Generator Start

Function and benefits

The Xantrex Automatic Generator Start (Auto Gen Start) automatically starts and stops your generator using dry contact relays to operate the auto-start function of your generator. (Dry contacts operate only as switches. The Auto Gen Start does not provide any voltage or current to the connections.)

The Auto Gen Start continuously monitors your power system and starts the generator if the battery voltage or state of charge reaches preset limits, or the air conditioner or heater needs to be run. The Auto Gen Start also starts the generator to assist the inverter/charger when power demands are high. When properly configured, the Auto Gen Start ensures that your power requirements are met and that your batteries stay charged.

Applications

The Auto Gen Start is ideal for users who desire the convenience of automatic generator starting when dry camping or when shore power is otherwise unavailable.

System component

The Auto Gen Start uses Xanbus™, a network communications protocol developed by Xantrex, to communicate its settings and activity to other Xanbus-enabled devices. You can configure and monitor the Auto Gen Start and every Xanbus-enabled device in the system using a single System Control Panel.

Xanbus-enabled products are:

- Easy to use. The Xanbus system simplifies operation and automates routine tasks.
- Reliable. Software control eliminates errors due to analog signalling.
- Accurate. Digital information is less susceptible to interference and line loss.
- Upgradable. Firmware upgrades mean your purchase will remain up to date.

For detailed instructions and a complete list of Xanbus-enabled devices, visit our website at www.xantrex.com.



Features

Generator starting	<p>The Auto Gen Start can automatically start a generator in response to:</p> <ul style="list-style-type: none">• low battery voltage• low battery capacity (“state of charge”)• high inverter load• a thermostat signal• a pre-programmed exercise period <p>You can also use the Auto Gen Start to manually start and stop the generator at any time.</p>
Generator compatibility	<p>The Auto Gen Start supports two and three-wire generator starters. It starts generators made by Onan (Quiet Diesel, gasoline, and LP), Power Tech, Generac, Martin, Kohler, Honda, Yamaha, and others.</p>
Programmable features	<p>Quiet Time The Auto Gen Start also features a quiet time setting, which prevents the generator starting at night or during other inconvenient periods.</p> <p>Exercise Period During times of prolonged generator inactivity, the Auto Gen Start can be programmed to run (or “exercise”) the generator for a pre-defined period. This ensures the generator remains operational and that the starting battery stays charged.</p>
Status reporting	<p>The Auto Gen Start reports its operating mode, its settings, generator activity, and the reason for generator starts to the Xanbus system. You can view this information on the System Control Panel.</p>
Installation options	<p>The Auto Gen Start can be installed with an external shutdown input, a manual generator on/off switch, and an external on/off indicator light.</p>

System Requirements

The Auto Gen Start is not designed for stand-alone operation. It does not function in a simple system containing only an Auto Gen Start and a generator. The Auto Gen Start requires several other components for configuration and operation.

Generator The generator should have automatic starting capability. Some manufacturers of generators without this capability may sell an optional automatic engine control module that will simplify operation with the Auto Gen Start.

The generator should also supply a Generator Run signal, which the Auto Gen Start uses to detect whether the generator is running. Some generator manufacturers refer to this signal as the hour meter signal or Switched B+.

Control panel A separate control panel is required to configure the Auto Gen Start and monitor generator starting and stopping activity. The control panel also provides real-time clock information for the Auto Gen Start Quiet Time and Exercise Time features.

Network power supply The Auto Gen Start requires a Xanbus power supply to operate. Network power is carried by the network cables, and can be supplied by a Xanbus-enabled product (such as an inverter/charger) or an external Xanbus power supply.

As a device that draws network power, the Auto Gen Start consumes a maximum of 3 watts.

Start and stop triggers The Auto Gen Start requires a source of start and stop triggers for automatic operation. These triggers can come from:

- thermostat 12/24 V input.
- battery voltage, state of charge, and inverter load status. This information must be transmitted over the network by another Xanbus-enabled device, such as an inverter/charger or DC Monitor.

When network-broadcast battery voltage, state of charge, and inverter load information are not available, the Auto Gen Start could operate in a reduced system with a control panel and network power supply. In this system, the Auto Gen Start would be limited to automatically starting and stopping the generator from thermostat 12/24 V input. In such a system, you could also start and stop the generator manually using the control panel, and Quiet Time, Exercise Time, and maximum run time settings would function.

Front and Bottom Panel

- Indicator lights** Four lights on the front panel indicate the operating status and network status of the Auto Gen Start.
- Connectors** Two network ports on the bottom panel connect the Auto Gen Start to the Xanbus system. A 20-contact pluggable connector (also on the bottom panel) allows the Auto Gen Start to connect to the generator’s starting circuitry, thermostats and external switches. See “Bottom panel” on page 1–6.

Front panel

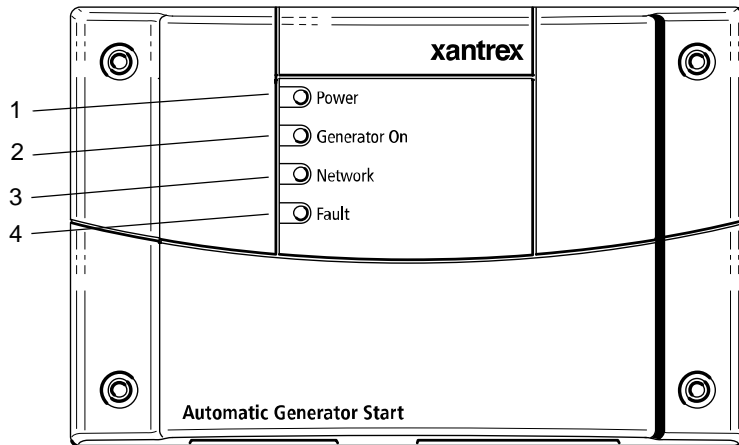

Figure 1-1 Auto Gen Start front panel

Table 1-1 Front panel features

Feature	Description
1	Power light (green) indicates the Auto Gen Start is receiving network power.
2	Generator On light (green) indicates the generator is running. This light turns on when the generator run signal is active. See “Important” on page 2–24.
3	Network light (green) indicates the Auto Gen Start is communicating with other Xanbus-enabled devices.
4	Fault light (red) indicates an Auto Gen Start fault has occurred. See “Troubleshooting” on page 5–1 for information about Auto Gen Start faults.

Bottom panel

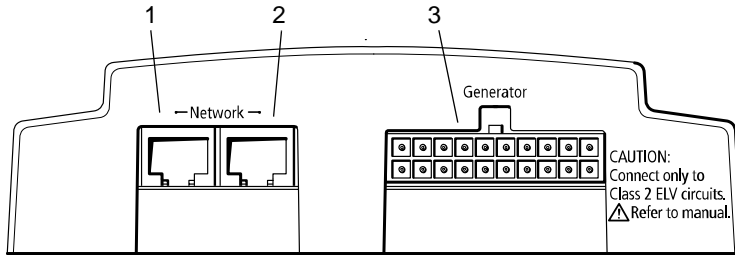

Figure 1-2 Auto Gen Start bottom panel

Table 1-2 Auto Gen Start connection points

Feature	Description
1	Network port (eight-pin RJ45)
2	Network port (eight-pin RJ45)
3	20-contact generator connector

Network connectors

Each network port can accept an eight-pin RJ45 plug attached to a CAT 5 cable. Depending on your installation, you may need to use one or both the network connectors. For more information, see the *Xanbus System Installation Guide*.



CAUTION: Equipment Damage

Connect the Auto Gen Start only to other Xanbus compatible devices.

Although the cabling and connectors used in this network system are the same as Ethernet connectors, **this network is not an Ethernet system**. Equipment damage may result from attempting to connect these two different systems.

20-contact connector

The 20-contact connector allows you to plug in a wiring harness that connects the Auto Gen Start to a generator and thermostats. The wiring harness also provides lines for connecting external generator shutdown sensors or switches and external generator on/off controls.

Xanbus System Components

System description

The Xantrex Xanbus system includes the Auto Gen Start and other Xanbus-enabled devices. Each device interacts and communicates with the other devices, creating a power system that can be precisely configured to your needs.

Network diagram

Figure 1-3 shows the Auto Gen Start as part of a Xanbus system.

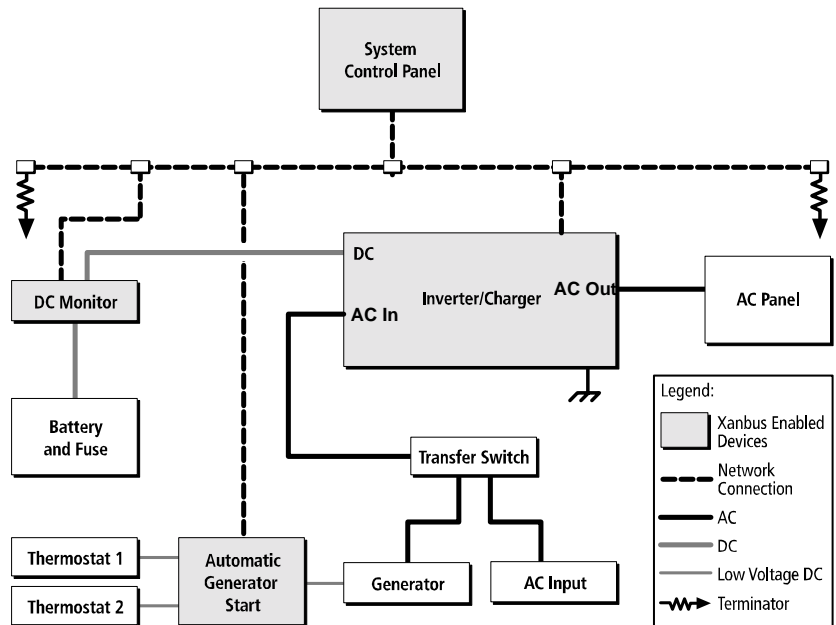

Figure 1-3 Xanbus system diagram

2

Installation

Chapter 2 contains information and procedures to install the Auto Gen Start.

This chapter will help you prepare to install the Auto Gen Start by providing:

- a summary of the tasks involved
- a list of materials and tools required
- recommendations for choosing an installation location

This chapter then provides procedures for mounting the Auto Gen Start, as well as guidelines for connecting it to:

- a generator
- thermostats
- the System Control Panel and other Xanbus-enabled devices

Preparing an Installation

Before you install the Auto Gen Start, you must consider how and where the unit will be mounted, and plan the connection routes between the Auto Gen Start, the generator, thermostats and the control panel.

Tools and materials required

Before beginning an installation, you will need the following tools and materials:

- Mounting template (supplied)
- Wiring harness (Xantrex part number 809-0917, supplied)
- Four #6 screws, 1 1/4 inch (supplied)
- #16 or #18 AWG wire (see “Wire size and length” on page 2–7)
- Xantrex network cables or equivalent
- Network terminators (if required)
- Phillips screwdriver
- Wire cutters
- Wire strippers

Choosing a location

The Auto Gen Start should be installed in a location that meets the following requirements:

- | | |
|---------------------------|---|
| Dry | The unit is intended for use in a dry location. The Auto Gen Start complies with UL458 Marine Supplement drip-test requirements, but the location should be as dry as possible. |
| Cool | The Auto Gen Start operates between -4 and 122 °F (-20 and 50 °C). |
| Safe | The Auto Gen Start is not ignition protected. Do not install it in areas requiring ignition-protected equipment, such as compartments housing gasoline engines. |
| Close to generator | Avoid excessive wire lengths and use the recommended wire lengths and sizes (see “Wire size and length” on page 2–7). It is more important for the Auto Gen Start to be close to the generator than close to the inverter, although for safety reasons, the Auto Gen Start should not be installed in the same compartment as a gasoline-powered generator. |

Routing the connections



WARNING: Explosion hazard

This equipment is not ignition protected. To prevent fire or explosion, do not install the Auto Gen Start in compartments containing flammable materials or in locations that require ignition-protected equipment. This includes any space containing gasoline-powered machinery, fuel tanks, as well as joints, fittings, or other connections between components of the fuel system.

Follow all relevant instructions exactly before installing or using your Auto Gen Start.



WARNING: Shock and energy hazards

Before making any connections to the generator, ensure that the generator’s starter is disabled and the generator’s start battery is disconnected.

Because the Auto Gen Start will be part of a Xanbus system, you must consider how to route two types of connections:

- connections to the generator, thermostats, and other external devices and switches, using the 20-contact connector and wiring harness.
- connections to other Xanbus-enabled devices, using network cables.

For information on designing and installing the network, see the *Xanbus System Installation Guide*.

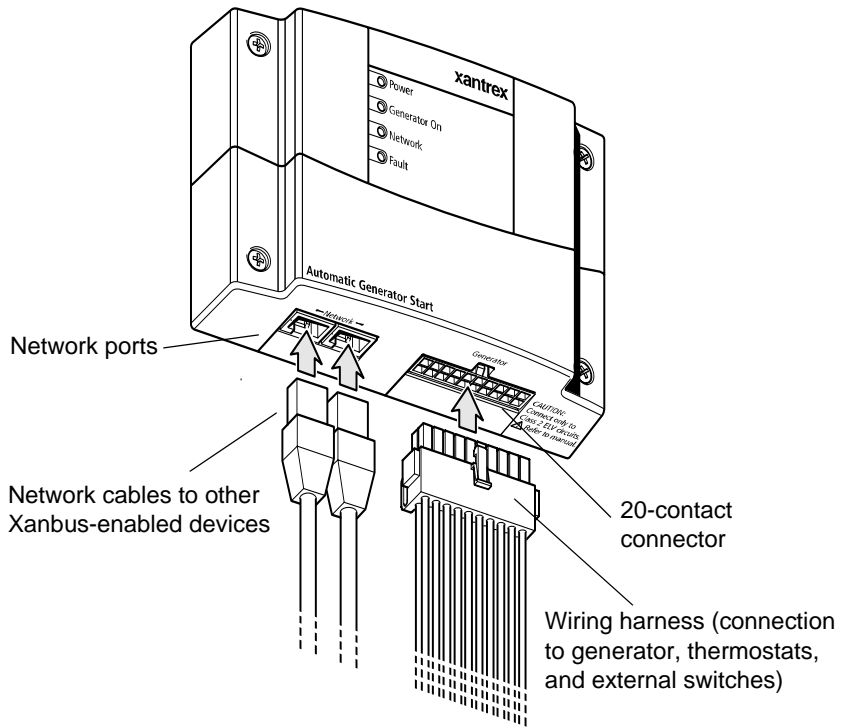

Figure 2-1 Auto Gen Start external connections

Installing the Auto Gen Start

After selecting your tools and choosing the best location and connection routes for your installation, you are now ready to mount the Auto Gen Start and connect it to the generator, thermostats and System Control Panel.

Installation overview

Installing the Auto Gen Start involves the following steps:

1. Mounting the unit.
2. Connecting the wiring harness to:
 - the generator (page 2–9)
 - thermostats (optional) (page 2–23)
 - external shutdown switch (optional) (page 2–23)
 - external on/off switch and LED (optional) (page 2–23)
3. Connecting the wiring harness to the 20-contact connector on the Auto Gen Start.
4. Connecting the Auto Gen Start to the System Control Panel and other network-enabled devices (page 2–26).

Note: Because each installation varies according to the location, the type of generator, and the overall complexity of the Xanbus system, these instructions can offer only general guidelines for the many installation options available.

Mounting the unit

The Auto Gen Start is to be mounted vertically on a wall with the connectors facing downwards.



WARNING: Shock hazard

Before installing the Auto Gen Start as part of a pre-existing Xanbus system, put the system in Safe mode in order to disable the electrical operation of networked devices. See “Changing System Modes” on page 4–6.

To mount the Auto Gen Start:

1. Hold the unit flush and square against the wall, panel or horizontal surface.
 - If your mounting surface requires you to pre-drill holes for the screws, use the supplied mounting template to mark, then drill, four holes.
2. With a Phillips screwdriver and the supplied #6 screws, secure each corner of the Auto Gen Start to the mounting surface.

Wiring to the 20-contact connector



WARNING: Shock hazard

All installation wiring should be performed by a qualified installer or electrician.



WARNING: Fire, shock, and energy hazards

The 20-contact connector is intended for connection to Class 2 ELV (Extra Low Voltage) circuits only. Do not exceed the circuit limitations specified in the following section.

ELV circuits

ELV (Extra-Low Voltage) circuits have an open-circuit voltage of not more than 30 V_{rms} or 42.2 VDC or peak, and are therefore not a shock hazard.

Class 2 circuits

As per the US National Electrical Code (NEC) and the Canadian Electrical Code (CEC), available power in Class 2 circuits is limited to 100 VA, usually by current limiting by means of overcurrent protection or series resistance. The current is limited to 5 A for circuits with open-circuit voltage of 20 V, and to $I=100/V_{oc}$ for circuits with open circuit voltage between 20 V and 30 V.

The advantage of using Class 2 circuits for installing the Auto Gen Start is that Class 2 circuits don't have to follow the Class 1 wiring rules (requiring the use of conduit and wiring boxes, et cetera) that apply elsewhere in the applicable codes.

Circuit limitations

The relay contacts in the Auto Gen Start are rated at 5 A maximum and all circuits on the 20-contact connector are rated at 30 V maximum.

Ensure that all circuits connected to the 20-contact connector obey the following limits:

Open circuit voltage (V_{oc})	30 V maximum
Overcurrent protection (fuse size for open circuit voltage up to 20 V)	5 A maximum
Overcurrent protection (fuse size for open circuit voltage from 20 V to 30 V)	5 A to 3.33 A ($100/V_{oc}$ amps maximum)

Wiring harness

Connections to the generator, thermostats, and external on/off switches are made using a wiring harness that plugs into the 20-contact connector (see Figure 2-1). The wires on the wiring harness can be extended to meet installation requirements. When extending the wire harness, ensure that the extension wires are the same color as the wires on the harness.

To install the Auto Gen Start using the wiring harness:

- 1. Connect each wire on the harness to its intended wire or contact on the generator, thermostats, or external switches.
- 2. Plug the harness into the connector on the bottom panel of the Auto Gen Start.

Wire identification

Each wire on the harness is identified by a number and a color. The wire numbers are shown in Figure 2-2 and their colors and functions are described in Table 2-1.

Wire size and length

Required wire sizes for the external connections to the wiring harness are:

0-30 ft. (9 m)	Over 30 ft. (9 m)
18 AWG	16 AWG

When planning the routing for external connections, ensure that wire lengths are sufficient to plug the wiring harness into the Auto Gen Start once all the external connections are complete.

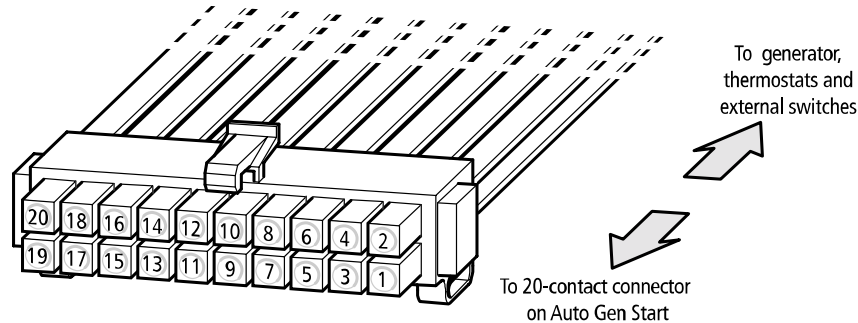

Figure 2-2 Auto Gen Start wiring harness

Table 2-1 Contact numbers and functions

Wire number	Function	Wiring harness wire color
1	Thermostat 1 input	Yellow
2	Thermostat 1 return	Gray
3	Thermostat 2 input	Orange
4	Thermostat 2 return	Gray
5	External shutdown input	White/Black
6	External shutdown return	Gray
7	External manual on input	White/Green
8	External manual off input	White/Red
9	External On/Off LED Indicator output	White/Blue
10	Constant 12/24 V B+ (battery positive) for External On/Off/LED Indicator	Red
11	External On/Off/LED Indicator return (connected internally to wire number 13)	Black
12	Generator run signal (switched B+) sense input	Violet
13	Generator run signal (switched B+) sense return (generator battery negative)	Black
14	Relay 1 (Generator run/stop) Normally open contact	Blue
15	Relay 1 (Generator run/stop) Normally closed contact	White/Violet
16	Relay 1 (Generator run/stop) Common contact	Gray
17	Relay 2 (Generator start) Normally open contact	White
18	Relay 2 (Generator start) Common contact	Gray
19	Relay 3 (Preheat/cooldown) Normally open contact	Brown
20	Relay 3 (Preheat/cooldown) Common contact	Gray

Connecting the generator

To connect the Auto Gen Start to a generator, you must identify the start wiring configuration of the generator you want to use. Generators must be auto-start capable, and generators equipped with remote operation connections are ideal.

If the generator is equipped for remote operation, you must examine the wiring of the remote cable and connector (or read your generator's documentation, if available) and identify the following wires:

- Ground
- Start
- Stop
- Generator run signal, also known as the Hour Meter or Switched B+ (battery positive)

Wiring requirements

To wire the Auto Gen Start to the generator, you need #16 or #18 AWG wire connected between contacts 12 to 20 on the wiring harness. How many of these wires you connect and in which combination depends on your generator type.

Generator types

The Auto Gen Start has 13 preset generator configurations, or “Gen Types” (see “Gen Type” on page 3–16). To ensure that the Auto Gen Start is compatible with your generator's starting circuitry, you must select your type of generator from the Auto Gen Start menu on the System Control Panel after completing the installation.

Important: You can only change “Gen Type” after you have put the system into Safe mode. See “Changing System Modes” on page 4–6.

This section describes the generator configurations and provides diagrams for connecting the wiring harness to the generator's start wiring.

Note: For an explanation of the terminology used in the following section, refer to Appendix B, “Generator Auto Start Requirements and Types”. For more information about Auto Gen Start internal relay activity and timing, see Appendix C, “Relay Timing”.

Type 1

Type 1 is a three-wire GlowStop configuration recommended for “three-wire” generators with glow plugs that need to be operated before a start is attempted.

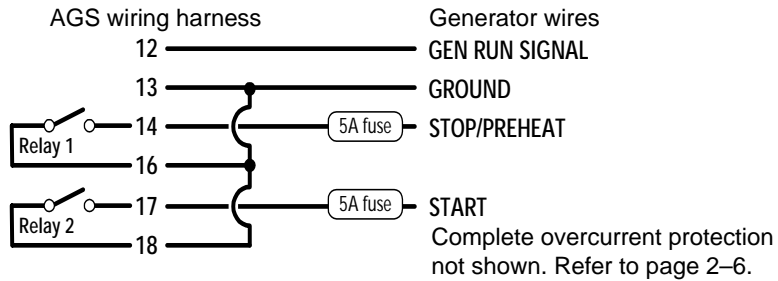

Figure 2-3 Type 1 connection diagram

Table 2-2 Type 1 relay and timing preset configurations

Relay 1 mode	GlowStop
Relay 3 mode	No function
Gen Run signal hold time	0.5 s
Preheat time	20 s
Preheat to crank delay	1 s
Crank time	15 s
Crank retry time	30 s
Shutdown bypass time	0 s
Start tries	3

Type 2

Type 2 is a three-wire GlowStop configuration recommended for “three-wire” generators that don’t require a dedicated preheat signal, such as Onan generators. In this configuration, the start signal is applied for longer because the generator does its own preheat and cranking while the start signal is applied.

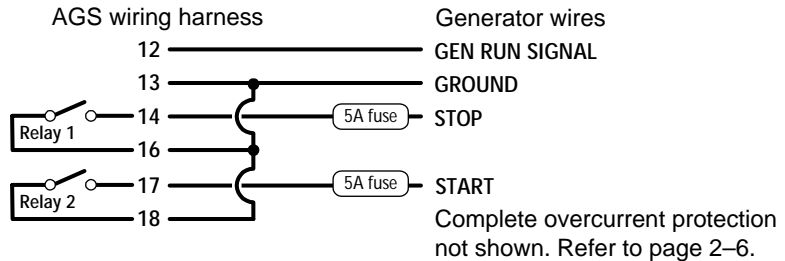

Figure 2-4 Type 2 and Type 12 connection diagram

Table 2-3 Type 2 relay and timing preset configurations

Relay 1 mode	GlowStop
Relay 3 mode	No function
Gen Run signal hold time	0.5 s
Preheat time	0 s
Preheat to crank delay	0 s
Crank time	30 s
Crank retry time	40 s
Shutdown bypass time	0 s
Start tries	3

Type 3

Type 3 is a three-wire GlowStop with shutdown bypass configuration. The configuration shown in Figure 2-5 uses a shutdown bypass output to temporarily disable the generator’s low oil pressure shutdown functionality during cranking. (Generators with this functionality often have a manual means of disabling it during cranking.)

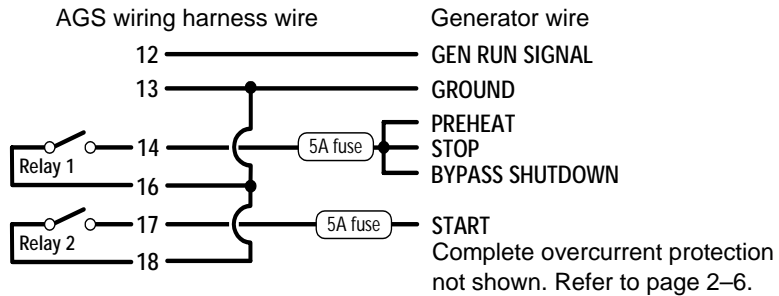

Figure 2-5 Type 3 connection diagram

Table 2-4 Type 3 relay and timing preset configurations

Relay 1 mode	GlowStop/Shutdown bypass
Relay 3 mode	Preheat/Shutdown bypass
Gen Run signal hold time	0.5 s
Preheat time	20 s
Preheat to crank delay	0 s
Crank time	15 s
Crank retry time	30 s
Shutdown bypass time	10 s
Start tries	3

Type 4

Type 4 is a three-wire StartStop configuration that uses relay 3 to provide the preheat signal for Generac’s Guardian Gas generators.

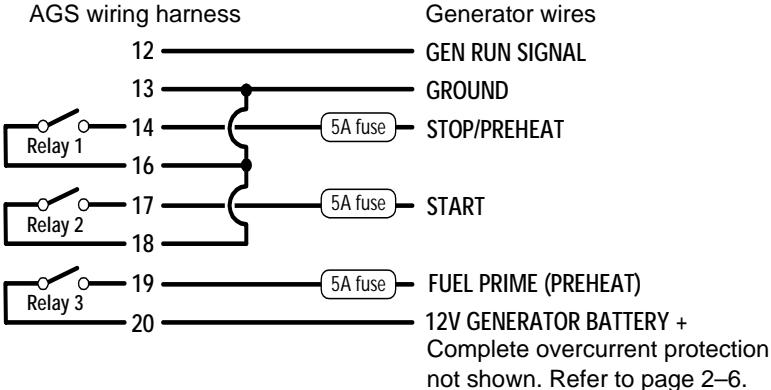

Figure 2-6 Type 4, Type 5 and Type 13 connection diagram

Table 2-5 Type 4 relay and timing preset configurations

Relay 1 mode	StartStop
Relay 3 mode	Preheat
Gen Run signal hold time	10 s
Preheat time	60 s
Preheat to crank delay	5 s
Crank time	15 s
Crank retry time	15 s
Shutdown bypass time	0 s
Start tries	3

Type 5

Type 5 is a three-wire StartStop configuration that uses relay 3 to provide the preheat signal for Generac's Guardian Diesel generators.

The wiring diagram for a Type 5 configuration is the same as a Type 4 (see Figure 2-6).

Table 2-6 Type 5 relay and timing preset configurations

Relay 1 mode	StartStop
Relay 3 mode	Preheat
Gen Run signal hold time	2 s
Preheat time	15 s
Preheat to crank delay	2 s
Crank time	15 s
Crank retry time	15 s
Shutdown bypass time	0 s
Start tries	3

Type 6

Type 6 is a three-wire GlowStop configuration that has a normally closed Run/Stop contact. This generator type is intended for Yamaha generators.

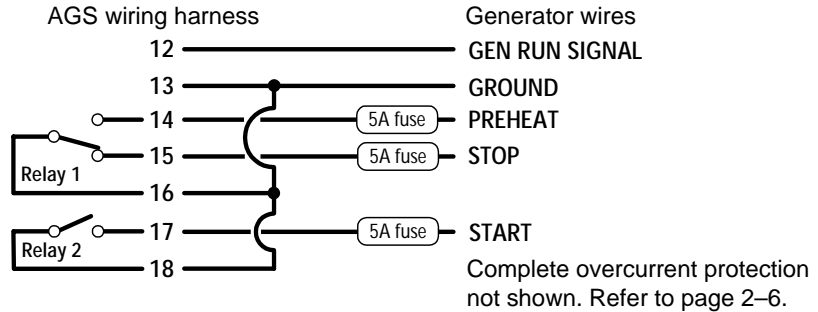

Figure 2-7 Type 6 connection diagram

Table 2-7 Type 6 relay and timing preset configurations

Relay 1 mode	GlowStop
Relay 3 mode	No function
Gen Run signal hold time	0.5 s
Preheat time	10 s
Preheat to crank delay	1 s
Crank time	15 s
Crank retry time	30 s
Shutdown bypass time	0 s
Start tries	3

Type 7

Type 7 will work with both two-wire and three-wire run mode configurations that require a preheat signal before cranking, such as Generac Backup/Renewable generators. This Gen Type setting is suitable for generators with an automatic engine cranking control system (two-wire) and generators that require that the Auto Gen Start control their starter separately (three-wire).

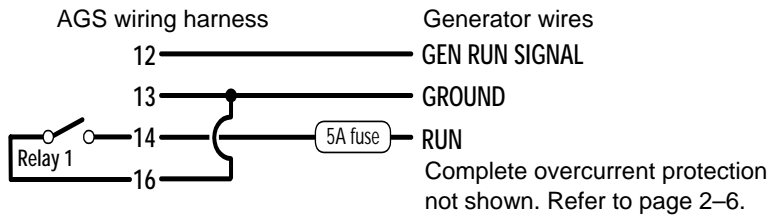

Figure 2-8 Type 7, Type 8, and Type 11 connection diagram (two-wire)

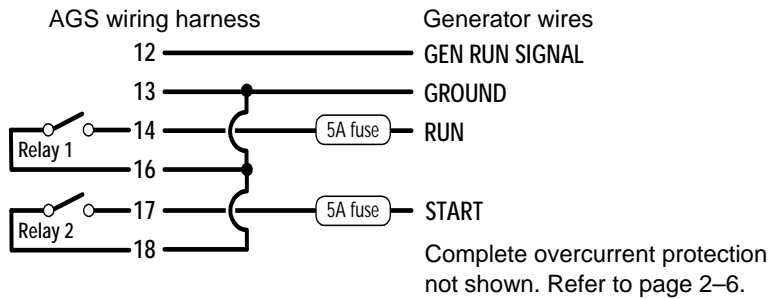

Figure 2-9 Type 7 and Type 8 connection diagram (three-wire)

Table 2-8 Type 7 relay and timing preset configurations

Relay 1 mode	Run
Relay 3 mode	No function
Gen Run signal hold time	0.5 s
Preheat time	20 s
Preheat to crank delay	1 s
Crank time	15 s
Crank retry time	30 s
Shutdown bypass time	0 s
Start tries	3

Type 8

Type 8 will work with both two-wire and three-wire run mode configurations and is intended for Northern Lights and Fisher Panda generators. Type 8 is identical to Type 7 except that it provides no preheat signal before cranking. See Figure 2-8 and Figure 2-9 for wiring diagrams.

Table 2-9 Type 8 relay and timing preset configurations

Relay 1 mode	Run
Relay 3 mode	No function
Gen Run signal hold time	0.5 s
Preheat time	0 s
Preheat to crank delay	0 s
Crank time	15 s
Crank retry time	30 s
Shutdown bypass time	0 s
Start tries	3

Type 9

Type 9 is a StartStop mode configuration with shutdown bypass functionality on relay 3. This configuration is intended for Westerbeke generators.

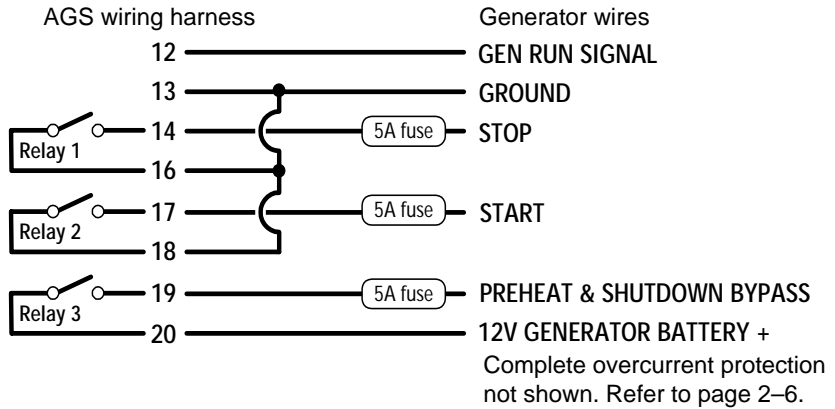

Figure 2-10 Type 9 connection diagram

Table 2-10 Type 9 relay and timing preset configurations

Relay 1 mode	StartStop
Relay 3 mode	Shutdown Bypass
Gen Run signal hold time	0.5 s
Preheat time	0 s
Preheat to crank delay	0 s
Crank time	15 s
Crank retry time	30 s
Shutdown bypass time	5 s
Start tries	3

Type 10

Type 10 is a StartStop mode configuration with no preheat signal or shutdown bypass functionality.

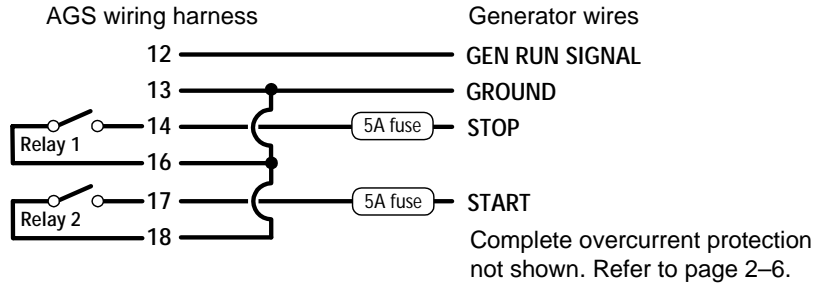

Figure 2-11 Type 10 connection diagram

Table 2-11 Type 10 relay and timing preset configurations

Relay 1 mode	StartStop
Relay 3 mode	No function
Gen Run signal hold time	0.5 s
Preheat time	0 s
Preheat to crank delay	0 s
Crank time	15 s
Crank retry time	30 s
Shutdown bypass time	0 s
Start tries	3

Type 11

Type 11 is a two-wire run mode configuration intended for Kohler generators. It requires only two wires and one relay to control the generator. Relay 1 closes momentarily once to start the generator, and closes momentarily again to stop the generator.

The wiring diagram for a Type 11 configuration is the same as a two-wire Type 7 configuration. See Figure 2-8.

Table 2-12 Type 11 relay and timing preset configurations

Relay 1 mode	MomentaryRun
Relay 3 mode	No function
Gen Run signal hold time	0.5 s
Preheat time	0 s
Preheat to crank delay	0 s
Crank time	10 s
Crank retry time	15 s
Shutdown bypass time	0 s
Start tries	3

Type 12

Type 12 is a three-wire GlowStop configuration recommended for “three-wire” generators that don’t require a dedicated preheat signal, such as Onan propane generators. In this configuration, the start signal is applied for longer because the generator does its own preheat and cranking while the start signal is applied.

The wiring diagram for a Type 12 configuration is the same as a three-wire Type 2 configuration. See Figure 2-4.

Table 2-13 Type 12 relay and timing preset configurations

Relay 1 mode	GlowStop
Relay 3 mode	No function
Gen Run signal hold time	4 s
Preheat time	0 s
Preheat to crank delay	0 s
Crank time	30 s
Crank retry time	40 s
Shutdown bypass time	0 s
Start tries	3

Type 13

Type 13 is a three-wire PulseStop configuration that uses relay 3 to provide the preheat signal for PowerTech’s Diesel generators. With this generator type, there will be a delay between the generator turning off and the Auto Gen Start recognizing that the generator is off.

The wiring diagram for a Type 13 configuration is the same as a Type 4 (see Figure 2-6).

Table 2-14 Type 13 relay and timing preset configurations

Relay 1 mode	PulseStop
Relay 3 mode	Preheat
Gen Run signal hold time	5 s
Preheat time	15 s
Preheat to crank delay	2 s
Crank time	15 s
Crank retry time	15 s
Shutdown bypass time	0 s
Start tries	3

Connecting the thermostats (optional)

Wires 1, 2, 3, and 4 on the wiring harness can be connected to two thermostats. Wires 1 (yellow) and 2 (gray) are intended for thermostat 1 and wires 3 (orange) and 4 (gray) are intended for thermostat 2.

Wire number	Function	Wiring harness wire color
1	Thermostat 1 input (12/24 V)	Yellow
2	Thermostat 1 return (ground)	Gray
3	Thermostat 2 input (12/24 V)	Orange
4	Thermostat 2 return (ground)	Gray

These wires connect to 12/24 V output signals from the thermostats. You can enable the Auto Gen Start to start the generator in response to these signals. You cannot program your thermostats with the Auto Gen Start.

For specific information about thermostat wiring and where Auto Gen Start connections should be made, please consult your thermostat documentation or contact the thermostat manufacturer.

Connecting an external shutdown (optional)

The external shutdown input is a 12/24V input used to assure that the Auto Gen Start keeps the generator off under conditions that may be potentially hazardous. Wire 5 (white/black) and 6 (gray) on the wiring harness are intended for an external switch or sensor (such as a moisture detector, carbon monoxide detector or coach running signal) that produces an active high 12V or 24V output.

Wire number	Function	Wiring harness wire color
5	External shutdown input (12/24 V)	White/Black
6	External shutdown return (ground)	Gray

Connecting an external manual on/off switch (optional)

The external manual on/off inputs (wires 7 and 8 on the wiring harness) are intended for wiring to one or more remote on/off switches for starting and stopping the generator manually. The other contact of the switch should be connected to ground. In order for the Auto Gen Start to be able to detect these switches, you must wire the positive of the generator battery to the constant 12V/24V generator battery positive (wire 10 on the Auto Gen Start wiring harness). See Figure 2-12.

If your generator battery does not have the required voltage, any 12V or 24V power source will suit this purpose. If an alternate power source is used, the negative of the power source must be connect to the other contact of the switch.

Wire number	Function	Wiring harness wire color
7	External manual on input	White/Green
8	External manual off input	White/Red
9	External On/Off LED Indicator output	White/Blue
10	Constant 12/24 V B+ for External On/Off/LED Indicator	Red
11	External On/Off/LED Indicator return	Black

Multiple control panels or simple contact closures can be wired to the external manual on/off inputs. The Auto Gen Start detects if any of the contacts close and will change its operating mode to External Manual On or External Manual Off (for more information, see “AGS Mode” on page 3–9). The Auto Gen Start turns the generator on or off according to these inputs and the resulting operating mode change.

Unlike the Manual On or Manual Off operating modes you can enter by using the System Control Panel, the External Manual On and External Manual Off states are not affected by maximum generator run time (see “Max Run Time” on page 3–29).

Connecting an external on/off LED

Wires 9 (White/Blue) and 11 (Black) on the wiring harness can be connected to an LED or other light to accompany a remote external on/off switch. This light turns on when the generator run signal is active to visually indicate that the generator is running.

Important:: With some generators, the generator run signal becomes active during the preheat stage, before the generator is actually running. In this case, the external on/off LED (and the Generator On light on the Auto Gen Start) will turn on during the preheat stage and remain on when the generator is running. For some generators, these lights will also remain on for a period of time after the generator has stopped.

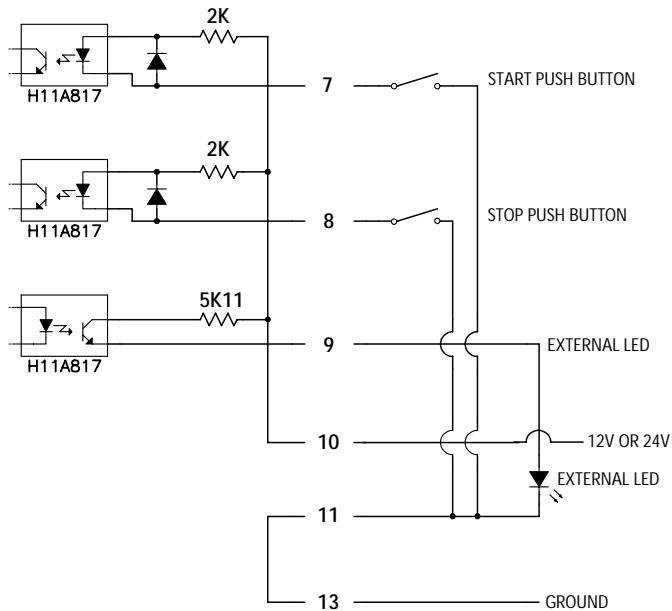

Figure 2-12 External on/off switch and LED wiring diagram

Connecting the wiring harness to the Auto Gen Start

After all the external connections have been wired to the wiring harness, the connector on the wiring harness must be plugged into the 20-contact connector on the Auto Gen Start.

To connect the wiring harness to the Auto Gen Start:

- ◆ With the click-tab on the wiring harness connector on top (facing you), insert the wiring harness connector into the 20-contact connector on the Auto Gen Start until the tab clicks into place.

Connecting the control panel and other network-enabled devices



CAUTION: Equipment damage

Connect only to other Xanbus-enabled devices.

Although the cabling and connectors used in this network system are the same as Ethernet connectors, **this network is not an Ethernet system**. Equipment damage may result from attempting to connect these two different systems.

To connect the Auto Gen Start to a System Control Panel or another network-enabled device, plug a Xantrex network cable or equivalent from another device into one of the network connectors on the bottom panel of the Auto Gen Start. See Figure 2-1 on page 2–4.

If the Auto Gen Start is being installed on an existing Xanbus system, the system must first be put into Safe mode. See “Changing System Modes” on page 4–6.

Depending on the layout of the Xanbus system, you have the following options for the other network connector on the Auto Gen Start:

- A second network cable (in a “daisy-chain” network layout)
- A network terminator (in a “daisy chain” network layout where the Auto Gen Start is the last device at one end of the network)
- Nothing (in a multi-drop backbone layout)

Verifying power is available

When the Auto Gen Start has been installed properly, the Power and Network indicator lights turn on.

If one or both lights are out, check the network connections and ensure the network power supply is on.

3

Configuration

Chapter 3 contains information and procedures for configuring the Automatic Generator Start. It describes how you can view the Auto Gen Start menu on the System Control Panel, and how you can change Auto Gen Start settings using the System Control Panel.

Chapter 3 also discusses each Auto Gen Start setting by:

- Defining each setting.
- Listing the available values for each setting.
- Recommending when to use each setting.
- Describing the effect of changing each setting.

Configuring the Auto Gen Start

The Auto Gen Start has a number of settings that you must configure to ensure that the generator automatically starts and stops under the right conditions and at the right time.

If your Auto Gen Start was pre-installed in your Xanbus system, it may already be configured to work with your generator and network-enabled power system. If this is the case, you may not have to configure any settings other than the Generator mode (see page 3–9) and Quiet Time (see page 3–11).

Using the System Control Panel

The Auto Gen Start is configured using the System Control Panel. You can view all the available Auto Gen Start settings on the System Control Panel screen.

The System Control Panel has four navigation buttons that you use to move between screens and menus, highlight settings you want to change, and select values for the Auto Gen Start to use.

See Figure 3-1 and Table 3-1 for the location and function of the navigation buttons on the System Control Panel.

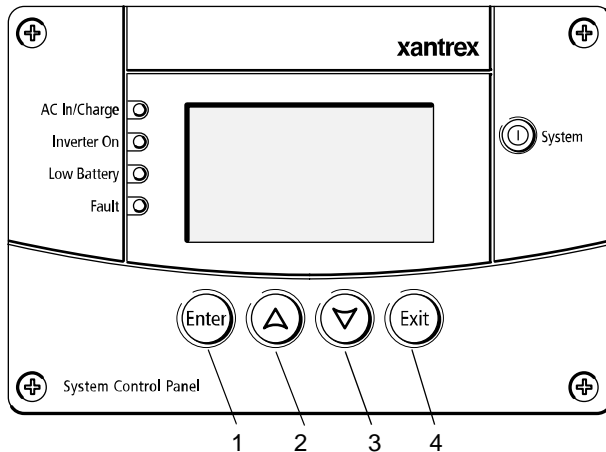

Figure 3-1 System Control Panel

Table 3-1 System Control Panel navigation buttons

Number	Button	Function
1	Enter	<ul style="list-style-type: none"> • Confirms selection of a menu item • Moves to the next screen
2	Up arrow	<ul style="list-style-type: none"> • Scrolls up one line of text • Increases a selected value
3	Down arrow	<ul style="list-style-type: none"> • Scrolls down one line of text • Decreases a selected value
4	Exit	<ul style="list-style-type: none"> • Cancels selection of a menu item • Returns you to the previous screen

Changing Auto Gen Start settings using the System Control Panel

If you need to change an Auto Gen Start setting, use the buttons on the System Control Panel to perform three basic steps:

1. View the Select Device menu.
2. Select the Auto Gen Start from the Select Device menu.
3. Select and adjust a changeable setting on the Auto Gen Start menu.

Each of these three steps is described in detail in the following sections.

Viewing the Select Device menu

The Select Device menu is where you select a Xanbus-enabled device to monitor or configure. The number of items on the Select Device menu depends on how many devices are installed in your Xanbus system.

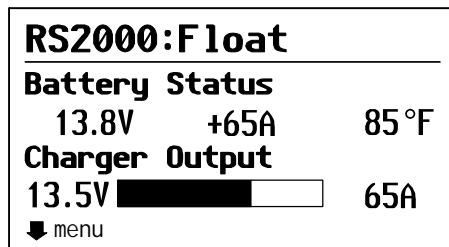

Figure 3-2 System screen (example)

To view the Select Device menu:

- ◆ On the System screen (see Figure 3-2), press Enter.

Important: You can always identify the System screen by the menu arrow in the bottom left corner of the screen. The menu arrow indicates the Enter button on the System Control Panel, which you press to view the Select Device menu.

Viewing the Auto Gen Start menu

On the Select Device menu, select the Auto Gen Start to view and change its settings.

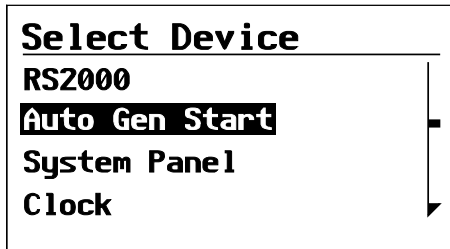

Figure 3-3 Selecting the Auto Gen Start

To select the Auto Gen Start from the Select Device menu:

1. On the Select Device menu, use the down arrow button to highlight Auto Gen Start.
2. Press Enter.

The Auto Gen Start menu appears.

Selecting and adjusting the changeable setting

On the Auto Gen Start menu, you can view and change Auto Gen Start settings, and monitor generator starting activity.

Changeable settings are identified by the square brackets [] around the values along the right side of the screen.

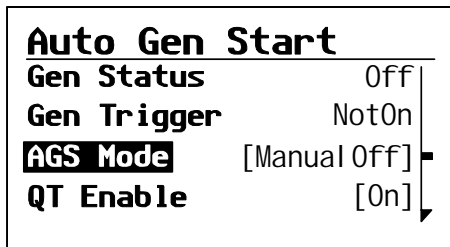

Figure 3-4 Auto Gen Start menu (basic menu shown)

To select and adjust a changeable setting:

1. On the Auto Gen Start menu, use the up arrow or down arrow button to highlight the setting you want to change.
2. Press Enter to highlight the current value of that changeable setting. Some values appear with an asterisk (*) to identify them as the value that was last set.
3. Use the up arrow or down arrow button to change the value. Hold a button down to scroll through values quickly.
4. Press Enter to select the value.
5. If you have another setting to change, return to step 1.

Or

If you have no more settings to change, press Exit twice to return to the System screen.

The Auto Gen Start Menu

The Auto Gen Start menu contains status information and settings. You can display the Auto Gen Start menu in two formats: basic and advanced.

Basic menu

The basic menu contains settings you may have to adjust routinely. The System Control Panel shows the basic menu by default.

Advanced menu

The advanced menu contains several sub-menus that include all items on the basic menu, as well as additional configurable settings. These sub-menus are:

- AGS Triggers menu (see page 3–19).
- Generator Configuration menu (see page 3–28)
- Device Info screens (see page 3–35)

On the advanced menu you can also return to the basic menu format.

To view the advanced menu, see page 4–5.

BASIC MENU

- Auto Gen Start
- Gen Status
- Gen Trigger
- AGS Mode
- QT Enable
- QT Begin
- QT End
- Start SOC*
- Start DCV
- Enable Temp1
- Enable Temp2
- Gen Type
- Clear Faults

*Items do not appear if DC Monitor is not installed

ADVANCED MENU

- Auto Gen Start
- Gen Status
- Gen State
- Gen Trigger
- AGS Mode
- QT Enable
- QT Begin
- QT End
- Gen Type

Configure Triggers

Configure Gen

Clear Faults

View Device Info

Basic Menu

AGS Gen Config

- Starter Cool Down
- Max Run Time
- Exercise Per
- Exercise Dur
- Exercise Time
- Relay3
- Run Hold Time
- Crank Time
- Crank Retry Time
- Preheat Time
- Start Tries

AGS Device Info

- View Fault Log
- View Warning Log
- View Event Log
- Restore Defaults

AGS Triggers

- Start SOC*
- Stop SOC*
- StartV:30sec
- StartV:15min
- StartV:2hr
- StartV:24hr
- Stop BattV
- Enable Temp1
- Enable Temp2
- Enable Load
- Start Load
- Stop Load
- Stop Absorb
- Stop Float

Figure 3-5 Auto Gen Start menu contents

The Auto Gen Start basic menu

The Auto Gen Start basic menu lists settings you may have to adjust routinely. The System Control Panel displays the Auto Gen Start basic menu by default.

If you would like additional control over automatic generator starting, you can find more settings on the Auto Gen Start advanced menu and AGS Triggers menu (see “Auto Gen Start advanced menu” on page 3–18 and “AGS Triggers menu” on page 3–19). However, you may not have to adjust these settings as part of regular operation.

The Auto Gen Start basic menu consists of the following items:

- “Gen Status” (status item)
- “Gen Trigger” (status item)
- “AGS Mode”
- “QT Enable”
- “QT Begin”
- “QT End”
- “Start SOC”
- “Start DCV”
- “Enable Temp1”
- “Enable Temp2”
- “Gen Type”

You can record any settings you change in the “User Settings” table on page 3–36.

Gen Status

Full name Generator Operating Status

Purpose “Gen Status” reports the current operating state of the generator. You cannot adjust any “Gen Status” values.

Value	Description
On	The generator is running.
Off	The generator is not running.
Fault	A fault condition exists. The Auto Gen Start is not controlling the generator, or the Auto Gen Start has an internal fault. If the generator is still running in a fault state, it may be stopped at the generator or by one of the generator’s control panels. See “AGS Mode” and “Troubleshooting” on page 5–1.

Gen Trigger

Purpose “Gen Trigger” reports the source of the active generator start trigger. Start triggers can include battery voltage, inverter load, battery state of charge, thermostat triggers, or exercise period. You cannot adjust any “Gen Trigger” values.

Value	Description
NotOn	Generator is not running
LowBattV	Preset minimum battery voltage with associated time delay
CntctClosed	Activated thermostat 1 or 2
BattSOCLow	Preset minimum battery state of charge
ACIHigh	Preset maximum inverter load current
Exercise	Preset exercise period, exercise time, and exercise duration
ManualOn	Started manually using System Control Panel
ExtOnviaAGS	Started by external switch connected to Auto Gen Start
ExtOnviaGen	Started by switch connected to generator
UnableToStop	Auto Gen Start has lost control of the running generator

AGS Mode

Purpose “AGS Mode” is a changeable setting that controls the current operating mode of the Auto Gen Start.

Value	Description
Automatic	Automatic mode
ManualOn	Manual on mode
ManualOff	Manual off mode (default mode)

When to use You should change “AGS Mode” when you want to switch between automatic generator control and manual generator control.

When the Xanbus system powers up all network-enabled devices, the Auto Gen Start is in Manual Off mode. To enable automatic generator starts, you must put the Auto Gen Start in Automatic mode.

Automatic If you would like the Auto Gen Start to start and stop the generator automatically, select Automatic. The generator can start and stop automatically in response to low battery voltage, low battery state of charge (requires a DC Monitor in the Xanbus System), AC loads on the inverter, thermostat triggers, or exercise time. Automatic mode also has a Quiet Time feature, which prevents the generator from starting during evening hours or other inconvenient times (see “QT Begin” on page 3–11, “QT End” on page 3–13, and “Setting Quiet Time” on page 4–3).



WARNING: Fire and health hazard

Running a generator in an enclosed space produces potentially lethal exhaust gases.

Before putting your RV or boat in storage, disable the Auto Gen Start by putting the Xanbus system in Hibernate mode. Do not leave a generator connected to an Auto Gen Start otherwise unattended.

Automatic mode overrides When the Auto Gen Start is in Automatic mode, several settings and conditions override automatic start and stop triggers. These overrides include, in order of priority:

- **Faults**—The Auto Gen Start stops the generator when a fault occurs.

- **External Shutdown**—When the Auto Gen Start is connected to a sensor or meter (a moisture detector, for example) wired to contacts 5 and 6 of the 20-contact connector, it stops the generator when the device is activated. See “Connecting an external shutdown (optional)” on page 2–23.
- **External On/Off**—The generator is manually started or stopped with a switch wired to contacts 7 and 8 of the 20-contact connector. See “Connecting an external manual on/off switch (optional)” on page 2–23. When started with an external manual on/off switch, the generator will not stop when it reaches Max Run Time. You must stop the generator using the external manual on/off switch.
- **Max Run Time**—When the generator has exceeded its maximum run time, a warning message will appear on the System Control Panel. The Auto Gen Start will stop operating until you acknowledge the warning by pressing Enter on the System Control Panel. See “Max Run Time” on page 3–29.
- **Manual On**—The generator is started by selecting Manual On mode.
- **Manual Off**—The generator is stopped by selecting Manual Off mode.

Manual On When you need to manually start the generator, select Manual On. Selecting Manual On mode overrides the automatic start settings and manually starts the generator. The generator will run until it is manually stopped or until it reaches its Auto Gen Start-defined Maximum Run Time (see “Max Run Time” on page 3–29).

Manual Off When you need to manually stop the generator, select Manual off. Selecting Manual Off mode overrides the automatic stop settings and manually stops the generator. You must select Manual Off to stop the generator when the generator has been started manually. The Auto Gen Start will not automatically start the generator again until you select Automatic.

Important: The Auto Gen Start mode must be set to Manual Off before you change any start trigger parameters.

QT Enable

Full name Quiet Time Enable

Purpose “QT Enable” enables or disables the Quiet Time functionality of the Auto Gen Start.

“QT Enable” applies only when the Auto Gen Start is in Automatic mode.

Value	Description
On, Off	Enable or disable the Quiet Time functionality.

When to use When you need to use the Auto Gen Start Quiet Time feature, set “QT Enable” to On, then check or reset the times you have set for “QT Begin” and “QT End”.

When you have no preferences or restrictions for when the generator should run, set “QT Enable” to Off.

Outcomes Selecting On enables the Quiet Time feature. If the Auto Gen Start is in Automatic mode, the Auto Gen Start stops and starts the generator according to the times you have set for “QT Begin” and “QT End”.

Selecting Off disables the Quiet Time feature. The Auto Gen Start will ignore the times you have set for “QT Begin” and “QT End”. If the Auto Gen Start is in Automatic mode, the Auto Gen Start starts and stops the generator at any time of the day or night in response to battery voltage, battery state of charge, inverter load, thermostat triggers, and exercise time.

QT Begin

Full name Quiet Time Begin

Purpose “QT Begin” is a changeable setting that defines the start of quiet time. This setting also requires you to set “QT End”.

Value	Description
12:00AM to 11:59PM (12-hour clock)	At the time you set for “QT Begin” the generator will stop (if it is running) and not be able to start again until the time you set for “QT End”. It ignores all automatic start triggers during the time period between “QT Begin” and “QT End”.
00:00 to 23:59 (24-hour clock)	

When to use “QT Begin” functions only if the Auto Gen Start is in Automatic mode.

Use the Quiet Time feature to ensure that the generator will not run during the night, or to comply with “Quiet Time” guidelines at RV parks and campgrounds.

To use the Auto Gen Start Quiet Time feature, first set “QT Enable” to On, then set two times of the day or night (a Quiet Time Begin time and a Quiet Time End time) to define a time interval during which the generator will not run.

To disable the Quiet Time feature, set “QT Enable” to Off.

Time zone

When travelling between time zones, ensure that you set the clock on the System Control Panel to your correct local time. Otherwise, your quiet time settings will come into effect too early or too late.

Battery drain

Quiet Time prevents the automatic starting of the generator regardless of battery condition.

If you need to set a quiet time that lasts overnight, be aware that overnight battery drain can be significant. Because you may need to use an inverter and batteries to supply AC power during quiet time, be careful to conserve battery power. Minimize the use of interior lights and set thermostat temperature lower to prevent the furnace from coming on at night during cool weather. Set thermostats higher to prevent air conditioning coming on at night during warm weather.

Outcomes

Sometimes automatic start or automatic stop triggers may overlap with the beginning and end of quiet time. Three different quiet time scenarios affect when the generator stops and starts.

1. If quiet time begins after the Auto Gen Start has started the generator, the generator will stop. If the condition that started the generator is still present when quiet time ends, the generator will restart.
2. If a condition that requires starting the generator occurs during quiet time, the Auto Gen Start will ignore it until quiet time ends. If the condition still exists at the end of quiet time (after the time you set for “QT End”), the Auto Gen Start will start the generator.
3. If the running generator stops when quiet time begins and a condition that requires stopping the generator occurs during quiet time, the generator will not restart when quiet time ends.

QT End

Full name Quiet Time End

Purpose “QT End” is a changeable setting that defines the end of quiet time. This setting also requires you to set “QT Begin”.

Value	Description
12:00AM to 11:59PM (12-hour clock)	At the time you set for “QT End” the Auto Gen Start will be able to automatically start the generator again. If a start trigger has occurred during quiet time and is still active, the generator will start immediately after quiet time ends.
00:00 to 23:59 (24-hour clock)	

When to use “QT End” functions only if the Auto Gen Start is in Automatic mode. For more information about when to use “QT End” and the Auto Gen Start Quiet Time feature, see “QT Begin” on page 3–11.

Start SOC

Full name Start Battery Charge

Purpose “Start SOC” is a changeable setting that allows the Auto Gen Start to start the generator when the battery bank capacity falls to a certain percentage. This setting requires you to set “Stop SOC” also (see page 3–19).

Values	Default
Off, 40% to 90% (increments of 5%)	Off (disabled)

When to use Discharging deep cycle RV or marine batteries below 50% capacity shortens their useful life. Correctly configuring the Auto Gen Start’s “Start SOC” setting can help protect your batteries from repeated over-discharge.

In Automatic mode, the Auto Gen Start will start the generator to recharge your batteries if the batteries’ state of charge is less than or equal to the “Start SOC” setting.

Important: To use the “Start SOC” setting, the Auto Gen Start requires accurate battery monitoring and state of charge information from the Xantrex DC Monitor. This menu item will not appear if a DC Monitor is not installed.

Configuration

State of charge information When a DC Monitor is installed, you can monitor the batteries' state of charge on the System screen or inverter/charger menu.

Outcomes If you set "Start SOC" too high, the generator will start more frequently than is convenient.

If you set "Start SOC" too low, your batteries may be damaged by repeated cycles of excessive discharge. The generator running time necessary to charge the batteries may exceed the Generator Run Max Time, and use too much fuel in the process.

Start DCV

Full name Starting Battery Voltage—30 seconds

Purpose "Start DCV" is a changeable setting that enables the Auto Gen Start to start the generator whenever the battery voltage reaches a pre-set voltage for longer than 30 seconds. You can also select the desired battery voltage with this setting.

The Auto Gen Start will stop the generator when the battery voltage has risen to the Stopping Battery voltage (see "StopBattV" on page 3-22), or when the batteries have been recharged to the Absorption or Float stage.

This setting requires you to set either "StopBattV", or a Stop at Charge Stage setting (see "Stop Float" on page 3-26 and "Stop Absorb" on page 3-25).

Values	Default
Off, 4.0V to 60.0V (increments of 0.1V)	11.3V

When to use If the Auto Gen Start is set to Automatic mode, then the Auto Gen Start will start the generator when the system battery voltage (as measured by the inverter/charger or DC Monitor) falls below the "Start DCV" setting for the selected delay period.

You can use the "Start DCV" setting when there is no accurate, reliable battery state of charge monitoring available, such as from the Xantrex DC Monitor.

Battery voltage information During normal operation, battery voltage can be monitored from the System screen or on the inverter/charger menu.

Whenever the generator starts automatically in response to “Start DCV”, it will stop when the battery voltage reaches the Stop Battery Voltage (“StopBattV”) setting. If you have enabled “Stop Float” or “Stop Absorb”, the generator will stop when the Absorption or Float stages of the battery charging have begun.

Outcomes If you set “Start DCV” too high, the generator will start more frequently than is convenient.

If you set “Start DCV” too low, your batteries may be damaged by repeated cycles of excessive discharge. The generator running time necessary to charge the batteries may exceed “Max Run Time”, and use too much fuel in the process.

Enable Temp1

Full name Enable Thermostat 1.

Purpose “Enable Temp1” is a changeable setting for starting the generator in response to a signal from a thermostat. With “Enable Temp1” set to On, the Auto Gen Start will start the generator to help power the furnace or the air conditioner.

Values	Default
On, Off	Off (disabled)

When to use Enable this setting if you have thermostats that control an air conditioning system with high power requirements.

Outcomes If you enable this setting, the generator will start in response to a signal from the thermostat. Everything related to setting the temperature at which the air conditioning system comes on must be done on the thermostat. There are no thermostat temperature settings on the Auto Gen Start or the System Control Panel.

If you disable this setting, your air conditioning system will operate without automatic generator assistance. To operate your air conditioner, you will need to start the generator manually, or connect to another AC input source.

Enable Temp2

Full name Enable Thermostat 2.

Purpose “Enable Temp2” is intended to be used when the Auto Gen Start is connected to a second thermostat. All information and procedures for “Enable Temp1” also apply for “Enable Temp2”.

Values	Default
On, Off	Off (disabled)

Gen Type

Full name Generator type

Purpose “Gen Type” is a changeable setting for selecting the starting requirements of your generator. The starting requirements determine how the Auto Gen Start must be wired to the generator’s starting system. For more information, see “Connecting the generator” on page 2–9 or Appendix B.

Important: You can only change “Gen Type” after you have put the system into Safe mode. See “Changing System Modes” on page 4–6.

Option	Description	
	Configuration	Mode
Type 1	General	GlowStop
Type 2	Onan Diesel (Default)	GlowStop with no preheat
Type 3	General	GlowStop with shutdown bypass
Type 4	Guardian/Generac Gas	StartStop with Relay 3 prime
Type 5	Guardian/Generac Diesel	StartStop with Relay 3 preheat
Type 6	Yamaha	GlowStop with normally closed RunStop contact
Type 7	Generac Backup/ Renewable	Run with preheat
Type 8	Northern Lights and Fisher Panda	Run with no preheat
Type 9	Westerbeke	StartStop with Relay 3 preheat and shutdown bypass

Option	Description	
	Configuration	Mode
Type 10	General	StartStop
Type 11	Kohler	MomentaryRun
Type 12	Onan Propane	GlowStop with no preheat
Type 13	PowerTech Diesel	PulseStop with Relay 3 preheat

When to use Use this setting after installing the Auto Gen Start. Selecting a suitable “Gen Type” automatically configures the Auto Gen Start to work with the ignition system and starting requirements of your generator. If you are not sure of your generator’s requirements, please consult your generator manual or contact your generator’s manufacturer.

Outcomes Selecting a “Gen Type” from the list automatically configures the following settings:

- Preheat time
- Preheat end to crank delay time
- Crank time
- Crank retry time
- Starter cooldown time
- Generator Run Signal hold time
- Start tries.

If your type of generator is not listed under “Gen Type”, you may need to manually configure some of the settings listed above (available on the Auto Gen Start advanced menu) using information from your generator manufacturer.

Clear Faults

Purpose “Clear Faults” clears all active Auto Gen Start faults. To clear the active faults, highlight Clear Faults and press Enter. For more information about how the Auto Gen Start treats faults and fault messages, see “Faults and Warnings” on page 5–2.

Auto Gen Start advanced menu

The Auto Gen Start advanced menu contains settings that can give you even more control over automatic generator starts and stops. To view the Auto Gen Start advanced menu on the System Control Panel, see page 4–5.

In addition to several items from the basic menu, the Auto Gen Start advanced menu contains the following sub-menus and commands:

- “Configure Triggers”
- “Configure Gen”
- “View Device Info”
- “Basic Menu”

Configure Triggers

Purpose Selecting “Configure Triggers” takes you to the AGS Triggers menu for further configuration of Auto Gen Start settings for starting and stopping the generator.

The Auto Gen Start mode must be set to Manual Off before you change the trigger parameters.

For more information, see “AGS Triggers menu” on page 3–19.

Configure Gen

Full name Configure Generator

Purpose Selecting “Configure Gen” takes you to the AGS Gen Cfg menu, where you can adjust settings related to your generator’s operating requirements. For more information, see “Generator Configuration menu” on page 3–28.

View Device Info

Purpose Selecting “View Device Info” takes you to the Device Info menu, where you can view Fault, Warning, and Event logs, and restore Auto Gen Start default settings.

For more information, see “AGS: Device Info menu” on page 3–35.

Basic Menu

Purpose Selecting “Basic Menu” returns the Auto Gen Start advanced menu to its basic format.

AGS Triggers menu

The AGS Triggers menu contains additional settings for automatically starting and stopping the generator. This menu allows you to adjust the default settings for state of charge (when a DC Monitor is installed), battery voltage, thermostat on/off signals, inverter load and battery charging stage.

Adjusting these settings beyond their default settings is advised for experienced users or users who have consulted service personnel.

Important: The Auto Gen Start mode must be set to Manual Off before you change any start trigger parameters.

The AGS Triggers menu contains the following items:

- “Start SOC”
- “Stop SOC”
- “StartV:30sec”
- “StartV:15min”
- “StartV:2hr”
- “StartV:24hr”
- “StopBattV”
- “Enable Temp1”
- “Enable Temp2”
- “Enable Load”
- “Start Load”
- “Stop Load”
- “Stop Float”
- “Stop Absorb”

Start SOC

See page 3–13.

Stop SOC

Full name Stop on State of Charge.

Configuration

Purpose “Stop SOC” is a changeable setting that allows you to set the Auto Gen Start to stop the generator when the batteries reach a pre-set state of charge.

Values	Default
Off, 50% to 95% (increments of 5%)	Off

When to use In Automatic mode, the Auto Gen Start will stop the generator when the batteries’ state of charge equals the “Stop SOC” setting.

Important: To use the “Stop SOC” setting, the Auto Gen Start requires accurate battery monitoring and state of charge information from the Xantrex DC Monitor. This menu item will not appear if a DC Monitor is not installed.

Stopping conditions After the Auto Gen Start starts the generator in response to the batteries’ state of charge, the generator can also stop when the batteries reach either the Float stage or the Absorption stage during recharging. For this scenario to work, you must enable “Stop Float” or “Stop Absorb”.

Outcomes If you set too high a value for “Stop SOC”, the generator may run for too long. For the purposes of the Auto Gen Start, 90% SOC is considered fully charged. If you find that your batteries are not fully charged using the “Stop SOC” setting, try using “Stop Float” or “Stop Absorb” instead. If you set too low a value for “Stop SOC”, the Auto Gen Start may stop the generator before the batteries are fully charged.

StartV:30sec

“StartV:30sec” is identical to the “Start DCV” setting. See page 3–14.

StartV:15min

Full name Starting Battery Voltage—15 minutes

Purpose “StartV:15min” enables the Auto Gen Start to start the generator whenever the battery voltage reaches a pre-set voltage for longer than 15 minutes.

This setting requires you to set either a Stopping Battery Voltage (“StopBattV”), or a Stop at Charge Stage (“Stop Float” or “Stop Absorb”) setting.

Values	Default
Off, 4.0V to 60.0V	Off (disabled)

When to use In Automatic mode, the Auto Gen Start will start the generator when the system battery voltage (as measured by the inverter/charger) falls below the “StartV:15min” setting for 15 minutes.

You can use one of the Starting Battery Voltage settings (“StartV:30sec”, “StartV:15min”, “StartV:2hr”, and “StartV:24hr”) when there is no accurate, reliable battery state of charge monitoring available, such as from the Xantrex DC Monitor.

Battery voltage information Battery voltage can be monitored from the System screen or the inverter/charger menu.

Whenever the generator starts automatically based on the Starting Battery Voltage, it will stop when the battery voltage reaches the “StopBattV” setting. If you have enabled “Stop Float” or “Stop Absorb”, the generator will stop when the Absorption or Float stages of the battery charging begin.

Outcomes If you set the Starting Battery Voltage too high, the generator will start more frequently than is convenient.

If you set the Starting Battery Voltage value too low, your batteries may be damaged by repeated cycles of excessive discharge. The generator running time necessary to charge the batteries may exceed “Max Run Time”, and use too much fuel in the process.

StartV:2hr

Full name Starting Battery Voltage—2 hours

Purpose “StartV:2hr” is a changeable setting that enables the Auto Gen Start to start the generator whenever the battery voltage reaches a pre-set voltage for longer than 2 hours.

This setting requires you to set either a Stopping Battery Voltage, or a Stop at Charge Stage setting.

Values	Default
Off, 4.0V to 60.0V	Off (disabled)

If the Auto Gen Start is set to Automatic mode, then the Auto Gen Start will start the generator when the system battery voltage (as measured by the inverter/charger) falls below the “StartV:2hr” setting for 2 hours. See “StartV:15min” for more information.

StartV:24hr

Full name Starting Battery Voltage—24 hours

Purpose “StartV:24hr” is a changeable setting that enables the Auto Gen Start to start the generator whenever the battery voltage reaches a pre-set voltage for longer than 24 hours.

This setting requires you to set either “StopBattV”, or a Stop at Charge Stage setting (“Stop Float” or “Stop Absorb”).

Values	Default
Off, 4.0V to 60.0V	Off (disabled)

If the Auto Gen Start is set to Automatic mode, then the Auto Gen Start will start the generator when the system battery voltage (as measured by the inverter/charger) falls below the “StartV:24hr” setting for 24 hours. See “StartV:15min” for more information.

StopBattV

Full name Stopping Battery Voltage

Purpose “StopBattV” is a changeable setting that allows the Auto Gen Start to stop the generator whenever the battery voltage reaches a pre-set DC voltage.

This setting requires you to set a Starting Battery Voltage also. See “StartV:30sec”, “StartV:15min”, “StartV:2hr”, and “StartV:24hr”.

Values	Default
Off, 14.0V to 60.0V (increments of 0.1V)	Off (disabled)

When to use Use the “StopBattV” setting when you have enabled and set a Starting Battery Voltage setting.

The “StopBattV” setting is most useful when you want the inverter/charger to give the batteries a quick, basic charge. To give the batteries a more complete, consistent charge, use the “Stop Float” setting.

Stopping conditions Whenever the generator starts automatically based on the Starting Battery Voltage, it will shut off once the Stopping Battery Voltage has been reached.

If “Stop Float” or “Stop Absorb” have been enabled, the Auto Gen Start will stop the generator if the Float or Absorption stages of the battery charging have begun.

Actual battery voltage can be monitored from the System screen on the System Control Panel.

Outcomes If you set “StopBattV” too high, the generator may run for too long.

If you set “StopBattV” too low, the Auto Gen Start will stop the generator before the inverter/charger has charged the batteries.

Enable Temp1

See page 3–15.

Enable Temp2

See page 3–16.

Enable Load

Full name Enable Inverter Load Start and Stop Triggers

Purpose “Enable Load” is a changeable setting that enables or disables the Start on Inverter Load Current and Stop on Inverter Load Current functionality of the Auto Gen Start. See “Start Load” and “Stop Load” on page 3–25.

“Enable Load” applies only when the Auto Gen Start is in Automatic mode.

Value	Description
On, Off	Enable or disable the Start on Inverter Load Current and Stop on Inverter Load Current functionality.

When to use When you need to use the Auto Gen Start “Start Load” (Start on Inverter Load Current) feature, set “Enable Load” to On, then check or reset the values you have set for “Start Load” and “Stop Load”.

Outcomes Selecting On enables the Start on Inverter Load Current (“Start Load”) and Stop on Inverter Load Current (“Stop Load”) functionality. If the Auto Gen Start is in Automatic mode and “Enable Load” is set to On, the Auto Gen Start stops and starts the generator according to the values you have set for “Start Load” and “Stop Load”.

 Selecting Off disables the Start on Inverter Load Current and Stop on Inverter Load Current functionality. When “Enable Load” is set to Off, the Auto Gen Start ignores the values you have set for “Start Load” and “Stop Load”.

Start Load

Full name Start on Inverter Load Current

Purpose “Start Load” is a changeable setting for enabling the generator to start at a specified AC load on the inverter. The generator will assist the inverter with powering the AC load.

 This setting requires you to set a value for “Stop Load” also.

Values	Default
10.0A to 33.0A (increments of 1A)	10.0A

When to use You should change this setting if you have certain “peak” times of power usage, or have power demands that consistently exceed the output of your inverter.

 If “Enable Load” is set to On, the generator will start in response to the “Start Load” setting unless the Auto Gen Start is in a Quiet Time period. Whenever the generator starts automatically in response to inverter load current, the Auto Gen Start will stop the generator once the load on the inverter reaches the Stop on Inverter Load Current value.

 You can monitor the inverter load current on the System screen.

Outcomes If you set “Start Load” too high, the Auto Gen Start may not start the generator in time to recharge the batteries before the batteries are drained by the AC load. In addition, if “Start Load” is set too high, the inverter may shut down due to an overload condition.

 If you set “Start Load” too low, the Auto Gen Start may start the generator too frequently, wasting fuel in the process.

Stop Load

Full name Stop on Inverter Load Current

Purpose “Stop Load” sets the Auto Gen Start to stop the generator at a specified AC load on the inverter. The “Stop Load” setting applies to situations when the Auto Gen Start has started the generator to assist the inverter with powering the AC load.

Values	Default
7.0A to 28.0A (increments of 1 A)	7.0A

When to use Use this setting when you have set a value for “Start Load”.

Stop Absorb

Full name Stop at Absorption Charge Stage

Purpose The “Stop Absorb” setting allows you to set the Auto Gen Start to stop the generator when the inverter/charger has recharged the batteries to the Absorption stage.

Values	Default
Off, On	On

When to use Set “Stop Absorb” if you want to deliver a partial charge to your batteries. The Auto Gen Start will start and run the generator until the inverter/charger charges the batteries through the Bulk charge stage (restoring the batteries to about 75% of their full charge). The Auto Gen Start stops the generator when the inverter/charger determines the batteries have reached the Absorption charge stage.

Set “Stop Absorb” if your inverter/charger is using two-stage battery charging. If your inverter/charger is set to use three-stage charging, set “Stop Float” or “Stop Absorb” to stop the generator.

Set “Stop Absorb” if battery charging is your main priority for your generator (rather than using your generator for powering high AC loads). You might also use the “Stop Absorb” setting if your batteries are not being charged enough before the Auto Gen Start stops the generator because of battery voltage or state of charge.

In power systems with long cables between the batteries and the inverter/charger (over 10 feet [3 m]), the measured battery voltage can be a poor indicator of battery condition. In such cases, the batteries are more assured of a full charge if the generator runs until the charger reaches the Absorb stage, rather than waiting until the charger charges the batteries to the voltage you may have set for “StopBattV” (see page 3–22).

For more information on battery charging, see your inverter/charger operation guide.

Outcomes

If you enable the Auto Gen Start to stop the generator at the Absorption stage, it will stop the generator if it has been started automatically by the Battery Voltage (“StartV:30sec”, “StartV:15min”, “StartV:2hr”, and “StartV:24hr”) or State of Charge settings.

If you do not set “Stop Absorb” to On, the Auto Gen Start will not stop the generator in response to the battery charging stage. The generator will stop in response to battery voltage (“StopBattV”) instead. In this case, ensure that the “StopBattV” is enabled and set at the correct voltage.

Stop Float

Full name

Stop at Float Charge Stage

Purpose

The “Stop Float” setting allows you to set the Auto Gen Start to stop the generator when the inverter/charger has recharged the batteries to the Float stage.

Values	Default
Off, On	Off

When to use

Set “Stop Float” if your inverter/charger is using three-stage battery charging.

Set “Stop Float” to On if battery charging is your main priority for your generator (rather than using your generator for powering high AC loads). You might also use the “Stop Float” setting if your batteries are not being charged enough before the Auto Gen Start stops the generator because of battery voltage or state of charge.

In power systems with long cables between the batteries and the inverter/charger (over 10 feet [3 m]), the measured battery voltage can be a poor indicator of battery condition. In such cases, the batteries are more

assured of a full charge if the generator runs until the charger reaches the Float stage, rather than waiting until the charger charges the batteries to the voltage you may have set for “StopBattV” (see page 3–22).

For more information on battery charging, see your inverter/charger guide.

Outcomes

If you enable the Auto Gen Start to stop the generator when the batteries have been charged to the Float stage, it will stop the generator if it has been started automatically by the Battery Voltage (“StartV:30sec”, “StartV:15min”, “StartV:2hr”, and “StartV:24hr”) or State of Charge settings.

If you do not set “Stop Float” to On, the Auto Gen Start will not stop the generator in response to the battery charging stage. The generator will stop in response to battery voltage (“StopBattV”) instead. In this case, ensure that the “StopBattV” is enabled and set at the correct voltage.

Generator Configuration menu

The Generator Configuration (AGS Gen Config) menu contains additional options for configuring the Auto Gen Start for your make and model of generator. The items on this menu include the settings you automatically select when you select a Gen Type (see “Gen Type” on page 3–16). This menu also allows you to set the generator exercise period.

The Generator Configuration menu contains the following items:

- “Starter Cool Down”
- “Max Run Time”
- “Exercise Per”
- “Exercise Dur”
- “Exercise Time”
- “Relay3”
- “Run Hold Time”
- “Crank Time”
- “Crank Retry Time”
- “Preheat Time”
- “Start Tries”

Starter Cool Down

Purpose The Starter Cool Down setting allows you to set an interval between start attempts if the generator fails to start on the first attempt. This time period allows the start motor to cool sufficiently before the Auto Gen Start signals it to begin cranking again.

Values	Default
1s to 250s (increments of 1s)	60s

When to use This setting is automatically configured when you select a “Gen Type” for your generator. You should manually set “Starter Cool Down” if you need to customize your “Gen Type” on the advice of your generator manufacturer or authorized service personnel.

Max Run Time

Full name Maximum Generator Run Time

Purpose The Max Run Time setting allows you to set a limit on how long the generator will run. This setting overrides any automatic start triggers. For example, if the generator starts in response to low battery voltage, and your batteries are not fully charged before “Max Run Time” is reached, the generator will stop. In addition, when the generator is started manually from the System Control Panel, the generator will stop when “Max Run Time” is reached.

When started with an external manual on/off switch, the generator will not stop when it reaches “Max Run Time”. You must stop the generator with the external manual on/off switch, or by using the System Control Panel to change the “AGS Mode” to ManualOff.

If the Auto Gen Start reaches “Max Run Time”, a warning message will appear on the System Control Panel. The Auto Gen Start will stop operating until you acknowledge the warning by pressing Enter on the System Control Panel.

Values	Default
2hours to 8hours (increments of 1hour)	3hours

When to use You should adjust “Max Run Time” if you find that the maximum generator run time:

- exceeds the fuel capacity of your generator.
- is not long enough to fully recharge your batteries under optimum conditions.

Exercise Per

Full name Set Exercise Period (in days).

Purpose “Exercise Per” allows you to set the minimum time interval in between each exercising of the generator.

The time interval defined by the Exercise Period setting begins with the last time the generator was run for any reason, not with the last time the Auto Gen Start exercised the generator.

For example, setting an exercise period of 30 days would start the generator if it had not been run at all for 30 days.

This setting also requires you to set an Exercise Duration (see “Exercise Dur” on page 3–30) and an Exercise Time (see “Exercise Time” on page 3–31).



WARNING: Fire and health hazard

Running a generator in an enclosed space produces potentially lethal exhaust gases.

Before putting your RV or boat in storage, disable the Auto Gen Start by putting the Xanbus system in Hibernate mode. Do not leave a generator with equipped with an Auto Gen Start otherwise unattended.

Values	Default
0 (Off), 1day to 250days (increments of 1day)	21days

When to use

Generators need to run regularly in order to maintain mechanical health and performance. If you have no need to use your generator (for example, if you are spending long periods of time connected to external AC input, or shore power), or if you use your generator for only one season a year, setting an exercise period is recommended.

If you run your generator frequently throughout the year, you may not need to set an exercise period. Set “Exercise Per” to 0.

Important: Consult your generator manual or a service representative from your generator’s manufacturer for the recommended exercise period.

Exercise Dur

Full name

Exercise Duration (in minutes)

Purpose

“Exercise Dur” allows you to set how long the generator will run when it is exercised.

This setting requires you to set an Exercise Period and an Exercise Time.

Values	Default
1min to 250min	30min

When to use

You must set the Exercise Duration when you have set the Exercise Period to anything other than 0 (Off).

Important: Ensure that you do not set Exercise Duration for longer than “Max Run Time”. Attempting to do so will generate a warning on the System Control Panel.

Important: Consult your generator manual or a service representative from your generator’s manufacturer for the recommended exercise duration.

Exercise Time

Purpose “Exercise Time” allows you to set the time of day that the Auto Gen Start exercises the generator.

This setting also requires you to set an Exercise Period and an Exercise Duration.

Values	Default
12:00AM to 11:50PM (12-hour clock) 00:00 to 23:50 (24-hour clock) (increments of 10 minutes)	9:00AM

When to use You must set the Exercise Time when you have set the Exercise Period and the Exercise Duration.

Outcomes If you have set the Exercise Time, the generator will start at that time after being inactive for the Exercise Period.

If the Exercise Time you have set occurs during Quiet Time, the generator will start when Quiet Time is over and run for the full amount of time you have set for “Exercise Dur”.

Relay3

Purpose “Relay3” sets the function of Relay 3 of the Auto Gen Start. The function of Relay 3 affects contacts 19 and 20 of the 20-contact connector and external wiring harness.

Values	Default
NotUsed, Preheat, PreheatSDByp	NotUsed

When to use Selecting a value for “Gen Type” automatically configures “Relay3”. You may have to manually set “Relay3” according to your make and type of generator.

Some diesel generators require preheating of their glow plugs before start cranking. Setting “Relay3” to Preheat enables Relay 3 to perform this function in addition to Relay 1.

Some generators require Relay 3 to switch 12 volts to the glow plugs, while some generators require ground to be switched to the glow plugs.

Run Hold Time

Full name Generator Run Signal Hold Time

Purpose “Run Hold Time” specifies the length of time the generator run signal (or B+ or hour meter signal) must be active before the Auto Gen Start considers the generator to be running and cranking can be stopped.

Some generators assert their run signal when they are being cranked, but before they have started. They also have varying delays from when cranking begins or ends to when the run signal is asserted or unasserted. The Run Hold Time is designed to accommodate these generators.

Values	Default
0.0s to 20.0s (increments of 0.5s)	0.5s

When to use This setting is automatically configured when you select a “Gen Type” for your generator. You should manually set “Run Hold Time” if you need to customize your Gen Type on the advice of your generator manufacturer or authorized service personnel.

Crank Time

Purpose “Crank Time” specifies the length of time the Start relay is engaged (and cranking the starter motor) for the first attempt to start the generator.

Values	Default
0s to 250s (increments of 1s)	30s

When to use This setting is automatically configured when you select a “Gen Type” for your generator. You should manually set “Crank Time” if you need to customize your Gen Type on the advice of your generator manufacturer or authorized service personnel.

Crank Retry Time

Purpose “Crank Retry Time” specifies the length of time the Start relay is engaged (and cranking the starter motor) for the second and subsequent attempts to start the generator, in cases when the generator fails to start on the first attempt.

Values	Default
0s to 250s (increments of 1s)	40s

When to use This setting is automatically configured when you select a “Gen Type” for your generator. You should manually set “Crank Retry Time” if you need to customize your Gen Type on the advice of your generator manufacturer or authorized service personnel.

Preheat Time

Purpose “Preheat Time” specifies how long the Preheat relay is engaged during the start sequence. The preheat signal may be required for diesel generators with glow plugs or fuel priming for gas generators.

The Preheat relay may be Relay 1 or Relay 3, depending on the “Relay3” setting or the Gen Type selected.

Values	Default
0s to 250s (increments of 1s)	0s

When to use This setting is automatically configured when you select a “Gen Type” for your generator. You should manually set “Preheat Time” if you need to customize your Gen Type on the advice of your generator manufacturer or authorized service personnel.

Start Tries

“Start Tries” specifies how many times the Auto Gen Start will attempt to start the generator. On the first start try, the Auto Gen Start cranks the starter motor for the Crank Time. If the generator does not start, on subsequent start tries, the Auto Gen Start cranks the start motor for the Crank Retry Time.

Values	Default
1 to 10	3

When to use

This setting is automatically configured when you select a “Gen Type” for your generator. You should manually set “Start Tries” if you need to customize your Gen Type on the advice of your generator manufacturer or authorized service personnel.

AGS: Device Info menu

The Device Info menu allows you to view the Fault, Warning and Event logs. On the Device Info menu you can also restore the default settings for the Auto Gen Start.

View Fault Log

Purpose	The Fault Log displays the last 20 Auto Gen Start faults for your reference.
When to use	You may need to consult the Fault Log when troubleshooting, or before seeking technical assistance.

View Warning Log

Purpose	The Warning Log displays the last 20 Auto Gen Start warnings for your reference.
When to use	You may need to consult the Warning Log when troubleshooting, or before seeking technical assistance.

View Event Log

Purpose	The Event Log displays the last 20 Auto Gen Start events for your reference. Events can include: <ul style="list-style-type: none">• Starting and stopping the generator.• Trigger events.• Changing the system mode.• Changing the system clock.• Commands to restore the default settings.
---------	--

Restore Defaults

Purpose	The Restore Defaults command restores the default settings for all configurable items on the Auto Gen Start menu.
When to use	Use the Restore Defaults command after installing a new generator, or if an authorized service person advises you to.

User Settings

Use this table to record any customized Auto Gen Start settings for future reference.

Setting	Values	Default	User Setting
“QT Begin”	12:00AM–11:59PM (12-hour clock) 00:00–23:59 (24-hour clock)	9:00PM (12-hour clock) 21:00 (24-hour clock)	
“QT End”	12:00AM–11:59PM (12-hour clock) 00:00–23:59 (24-hour clock)	8:00AM (12-hour clock) 8:00 (24-hour clock)	
“Gen Type”	Type 1 to Type 13	Type 2	
“StartV:30sec”	Off, 4.0V–60.0V	11.3V	
“StartV:15min”	Off, 4.0V–60.0V	Off	
“StartV:2hr”	Off, 4.0V–60.0V	Off	
“StartV:24hr”	Off, 4.0V–60.0V	Off	
“StopBattV”	Off, 4.0V–60.0V	Off	
“Enable Temp1”	On, Off	Off	
“Enable Temp2”	On, Off	Off	
“Enable Load”	On, Off	Off	
“Start Load”	10.0A–33.0A	10.0A	
“Stop Load”	7.0A–28.0A	7.0A	
“Stop Absorb”	On, Off	On	
“Stop Float”	On, Off	Off	
“Max Run Time”	2hours–8hours	3hours	
“Exercise Per”	0days (Off)–250days	21days	
“Exercise Dur”	1min–250min	30min	
“Exercise Time”	12:00AM–11:59PM (12-hour clock) 00:00–23:59 (24-hour clock)	9:00AM (12-hour clock) 9:00 (24-hour clock)	

4

Operation

Chapter 4 describes the operation of the Auto Gen Start and how to get the most from its features. This includes information about:

- using the Auto Gen Start for both manual and automatic generator control.
- setting Quiet Time.
- displaying the advanced Auto Gen Start menu.
- changing system modes.
- viewing the firmware revision number.

Starting and Stopping the Generator

You can use the Auto Gen Start to start the generator manually (on demand, using the System Control Panel) and automatically (in response to an electrical system condition).

In general, to avoid Auto Gen Start faults, try not to combine automatic and external manual starts and stops. When the generator has been started automatically, let it stop automatically unless you encounter a situation when the generator must be stopped urgently. Likewise, if you have started the generator manually, ensure that you stop it manually (only the “Max Run Time” setting can automatically stop the generator after it has been started manually).

To set the Auto Gen Start to start and stop the generator automatically:

1. On the Auto Gen Start menu, highlight AGS Mode and press Enter.
2. Use the up arrow or down arrow button to select Automatic.
3. Press Enter.

The Auto Gen Start will start and stop the generator in response to the configurable settings you have set for battery voltage, state of charge, inverter load, quiet time or exercise time. Depending on conditions in the power system, the generator may start immediately after it is put in Automatic mode.

To start the generator manually:

1. On the Auto Gen Start menu, highlight AGS Mode and press Enter.
2. Use the up arrow or down arrow button to select ManualOn.
3. Press Enter.

To stop the generator manually:

1. On the Auto Gen Start menu, highlight AGS Mode and press Enter.
2. Use the up arrow or down arrow button to select ManualOff.
3. Press Enter.

Setting Quiet Time

Use the Quiet Time feature to ensure that the Auto Gen Start will not start the generator during the night, or during times that might clash with “Quiet Time” guidelines at RV parks and campgrounds.

Setting Quiet Time for the first time involves three steps:

1. Setting “QT Enable” to On.
2. Setting the “QT Begin” setting.
3. Setting the “QT End” setting.

The default setting for “QT Begin” is 10:00 PM (22:00 if you are using a 24-hour clock) and the default setting for “QT End” is 7:00 AM (7:00 on the 24-hour clock). If the default settings meet your needs, you only need to enable or disable Quiet Time when you want to use this feature.

For more information about Quiet Time settings, see “QT Enable” on page 3–11, “QT Begin” on page 3–11, and “QT End” on page 3–13.

Enabling Quiet Time

Before setting times for the beginning and end of Quiet Time, you must first enable the Quiet Time feature, if it has not already been enabled.

To enable Quiet Time:

1. On the Auto Gen Start menu, use the up or down arrow buttons to highlight “QT Enable”.
2. Press Enter.
3. Use the up or down arrow button to select On.
4. Press Enter.

Setting the beginning of Quiet Time

Setting a time for “QT Begin” will define the start of Quiet Time. At the time you set for “QT Begin”, the Auto Gen Start will turn the generator off if it is running, and prevent the generator from starting automatically until the end of Quiet Time.

To set the beginning of Quiet Time:

1. On the Auto Gen Start menu, use the up or down arrow buttons to highlight “QT Begin”, then press Enter.
2. Use the up or down arrow button to select the hour, then press Enter.

3. Use the up or down arrow button to select the minute, then press Enter.
If you are using the 24-hour clock, go to step 5.
4. Use the up or down arrow button to select AM or PM, then press Enter.
5. Press Exit twice to return to the System screen.

Setting the end of Quiet Time

Setting a time for “QT End” defines the end of Quiet Time. At the time you set for “QT End”, the Auto Gen Start will be able to start the generator when an automatic start trigger (such as low battery voltage or a high inverter load) occurs in the Xanbus system. If there is an automatic start trigger already active in the system when Quiet Time ends, the generator will start immediately.

To set the end of Quiet Time:

1. On the Auto Gen Start menu, use the up or down arrow buttons to highlight “QT End”, then press Enter.
2. Use the up or down arrow button to select the hour, then press Enter.
3. Use the up or down arrow button to select the minute, then press Enter.
If you are using the 24-hour clock, go to step 5.
4. Use the up or down arrow button to select AM or PM, then press Enter.
5. Press Exit twice to return to the System screen.

Viewing the Advanced Menu

The System Control Panel can display the Auto Gen Start menu in two formats: basic and advanced.

The Auto Gen Start basic menu is displayed by default. It lists status information and settings you may have to adjust routinely. See “The Auto Gen Start basic menu” on page 3–7 for a list of basic menu items and configuration information.

The Auto Gen Start advanced menu lists additional settings and sub-menus. See “Auto Gen Start advanced menu” on page 3–18 for a list of advanced menu items and configuration information.

To view the Auto Gen Start advanced menu, you must go to the System Settings menu.

To view the Auto Gen Start advanced menu:

1. On the Select Device menu, use the down arrow button to highlight System (see Figure 4-1).

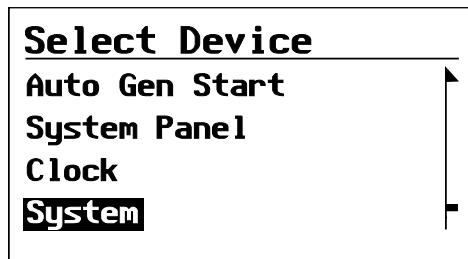

Figure 4-1 Selecting the System menu

2. Press Enter.
The System Settings menu appears.
3. On the System Settings menu, use the down arrow button to highlight Global Menus and press Enter.
4. Use the up or down arrow button to select Advanced.
5. Press Enter.

This procedure causes advanced menus to be displayed for all devices on the Xanbus system. You can return to displaying the basic menu for the Auto Gen Start by selecting Basic Menu on the Auto Gen Start menu.

Changing System Modes

The system modes described in this section affect the behavior of the Auto Gen Start and every Xanbus-enabled device in the system. You will have to change the system mode when setting a Generator Type, travelling, putting your vehicle in storage, or when installing a new Xanbus-enabled device.

The system modes you can select are:

- Operating
- Power Save
- Safe
- Hibernate

You can change system modes using the System Settings menu on the System Control Panel. The System Settings menu appears as the last item on the Select Device menu.

To view the System Settings menu:

1. On the Select Device menu, use the down arrow button to highlight System (see Figure 4-1).
2. Press Enter.

The System Settings menu appears.

To change the System mode:

1. On the System Settings menu, with Desired Mode highlighted, press Enter.

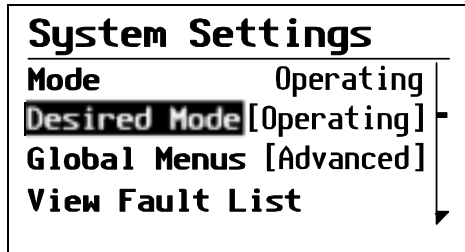

Figure 4-2 Changing the system mode

2. Use the up or down arrow button to selected the desired system mode.
3. Press Enter.

Operating mode

Characteristics Operating mode is the default mode of the Auto Gen Start. In Operating mode, the Auto Gen Start communicates on the network, responds to signal input, and can start and stop the generator automatically. Operating mode includes all the AGS Modes described on page 3–9 of the Configuration chapter.

Whenever the Auto Gen Start is powered on, it is in Operating mode (with the AGS Mode in “ManualOff”).

Power Save mode

Characteristics Power Save mode minimizes power draw by the Auto Gen Start and other devices on the Xanbus system. Power Save mode stops all communication on the network, putting the system to “sleep” until it receives a command to “wake up” again. In Power Save mode, the generator stops, and the Auto Gen Start cannot start it manually or automatically.

For more information about Power Save mode, see the System Control Panel Owner’s Guide.

Safe mode

Characteristics Selecting Safe mode stops the generator (if it is running) and puts the Auto Gen Start (and every Xanbus-enabled device in power system) into Safe mode. While in Safe mode, the Auto Gen Start “listens” to and reports its status to the network. However, it will not start the generator manually or automatically while in Safe mode.

When to use Before changing the “Gen Type” setting (see page 3–16), you must put the system into Safe mode.

Use Safe mode when adding or removing devices from the network. Authorized service personnel must also put the system into Safe mode before performing diagnostics and software upgrades.

If the Auto Gen Start is powered off while in Safe mode, it will be in Safe mode when it is powered on again.

Important: If Auto Gen Start Fault 201 (“Unable to stop gen.”) is active, you cannot put the Auto Gen Start into Safe mode. Before you can enter Safe mode, you must stop the generator via its external switch and clear the fault.

Hibernate mode

Characteristics Hibernate mode removes power from the Auto Gen Start and all Xanbus-enabled devices on the Xanbus system. The Auto Gen Start suspends all operations (including starting and stopping the generator) until power is restored to the network.

Important: Put the system into Hibernate mode before putting your RV or boat in storage. This will prevent the Auto Gen Start from starting the generator while unattended.

If there are active faults in the system, you cannot put the system into Hibernate mode. Clear any active faults, correct the condition that caused the fault, then put the system into Hibernate mode.

Restoring power Once the system is in Hibernate mode, you must restore power to the network manually.

If an inverter/charger supplies power to the network, you can bring the system out of Hibernate mode either by pressing the reset button on the inverter/charger front panel or by applying AC input to the inverter/charger with utility power or generator power.

Viewing the Firmware Revision Number

You may need to view the firmware revision number when troubleshooting the Auto Gen Start with authorized service personnel.

To view the firmware revision number:

1. On the Select Device menu, use the down arrow button to highlight System.
The System Settings menu appears.
2. Press Enter.
The System Settings menu appears.
3. Press the down arrow button to highlight View Device Info.
4. Press Enter.
The Device Info screen appears.
5. If Auto Gen Start screen is not already displayed, press the down arrow button until it appears.
The number opposite “F/W Rev.” is the firmware revision number.
6. Press Exit to return to the System Settings menu.

5

Troubleshooting

Chapter 5 contains information and procedures to troubleshoot the Auto Gen Start, including tables of warnings and faults for your reference.

Faults and Warnings

Under certain conditions, the Auto Gen Start generates a fault or warning message. These messages appear on the System Control Panel. This section describes how to respond to fault and warning messages when they appear.

Acknowledging messages

When a fault or warning message appears, you can acknowledge the message by pressing Enter on the System Control Panel. This action removes the message from the screen. After acknowledging the message, you can proceed configuring or operating the Auto Gen Start. This action does not clear the condition that caused the fault or warning, however. Consult Table 5-1 and Table 5-2 for suggested actions to take after you have acknowledged the message.

You can acknowledge warnings that are in the form of a Yes/No question by pressing Enter for Yes and Exit for No.

Self-clearing warnings

If unacknowledged, some warnings may clear themselves if the condition that generated the message goes away. For example, if the Auto Gen Start fails to start the generator, warning message W202 appears. However, if the generator starts on the next start try, the message goes away.

Clearing faults

To clear active Auto Gen Start faults, highlight Clear Faults on the Auto Gen Start menu and press Enter.

Multiple faults and warnings

If several fault or warning messages occur before you can acknowledge or clear them, they are displayed together on a fault list or a warning list. These lists contain messages from every Xanbus-enabled device, not just the Auto Gen Start. You can select a message and view its details from the fault list or warning list.

To view a message from a fault list or warning list:

1. On the list, use the up arrow or down arrow button to highlight the message you want to view.
2. Press Enter.

The complete message appears.

After viewing the message, you can return to the fault list or warning list by pressing Exit or continue to the menu for the device that caused the fault or warning by pressing Enter. Each time you return to the list after viewing a complete message, the viewed message is removed from the list.

If you have left the fault list or warning list, you can view them at any time from the System Settings menu.

To view a fault list or warning list:

1. On the Select Device menu, highlight System and press Enter.
2. On the System Settings menu, highlight View Fault List or View Warning List.
3. Press Enter.

Warning Messages

Table 5-1 provides details and suggests action for Auto Gen Start warnings.

Table 5-1 Auto Gen Start warning messages

Warning Number	Message	Self-clearing?	Cause	Action
W200	Generator was stopped manually.	No	Generator was stopped by an external Manual Off switch.	Acknowledge the warning. To resume automatic starts and stops, change the Auto Gen Start mode to Auto.
W201	Generator was started manually.	No	Generator was started by an external Manual On switch	Acknowledge the warning. To resume automatic starts and stops, change the Auto Gen Start mode to Auto.
W202	Unable to start generator. AGS will try again.	Yes	The Auto Gen Start tried, but could not start the generator.	No action required. The Auto Gen Start will try to start the generator again until it reaches the maximum number of start tries.
W203	Manual Off: Max generator run time reached. Reset AGS Mode.	No	The generator has run for its maximum allowable time. The Auto Gen Start has stopped the generator and changed the AGS Mode to ManualOff.	Acknowledge the warning. Return the Auto Gen Start to the desired AGS Mode (Automatic or ManualOn). Ensure generator is fueled and is supplying required power for battery charging and loads.

Table 5-1 Auto Gen Start warning messages

Warning Number	Message	Self-clearing?	Cause	Action
W204	Manual Off: Max generator cycles reached. Reset AGS Mode.	No	The generator has reached its maximum number of start-and-stop cycles. To help prevent an unattended generator from starting, the Auto Gen Start changed the AGS Mode to ManualOff.	Acknowledge the warning. Return the Auto Gen Start to the desired AGS Mode (Automatic or ManualOn). Ensure generator is fueled and is supplying required power for battery charging and loads.
W205	Generator started by its switch. Use its switch to stop.	Yes	The generator was started, but not by the Auto Gen Start.	Check your generator. Stop it using the switch or control panel on the generator.
W206	Mismatched triggers. Enable stop trigger or disable start trigger.	No	You have set a start trigger, but not a corresponding stop trigger.	Acknowledge warning and set a stop trigger.
W207	Mismatched triggers. Enable start trigger or disable stop trigger.	No	You have set a stop trigger, but not a corresponding start trigger.	Acknowledge warning and set a start trigger.
W208	Auto triggers not enabled. Config auto triggers	No	You are attempting to enter Automatic Mode without setting Auto triggers.	Acknowledge warning and set a start and stop trigger.
W209	Gen external stop. Start gen via its control panel.	Yes	The generator has stopped, but not by the Auto Gen Start. The generator may have run out of gas, or may have been shut off by a switch on the generator.	Check the generator's fuel level and mechanical condition, then start the generator manually (using the switch or control panel on the generator) to clear the warning.

Table 5-1 Auto Gen Start warning messages

Warning Number	Message	Self-clearing?	Cause	Action
W250	The selected value failed to change. Try again.	No	You have tried to change the Gen Type without putting the system into Safe mode first.	Press “continue.” Put the system into Safe mode, change the Gen Type, then return the system to Operating mode.
			You have tried to set the “Exercise Dur” for longer than “Max Run Time,” or “Max Run Time” for less than “Exercise Dur.”	Press “continue.” Ensure that “Max Run Time” is set for longer than “Exercise Dur.”
W500	Network connection lost. Check connections.	Yes	The Auto Gen Start has lost communications with the network because of a faulty connection or electronic signal disruption.	Check connection between the Auto Gen Start and the network.
W501	AGS has fixed memory problem and restored default settings.	No	The Auto Gen Start encountered an internal memory problem upon startup. To remain operational, the Auto Gen Start restored its default settings.	Acknowledge the warning and reset configurable settings if necessary.

Fault Messages

When the Auto Gen Start detects a fault condition, it stops the generator. The red Fault light also comes on, and the System Control Panel displays a fault message.

The Auto Gen Start remembers the AGS Mode that it was in at the time it detected the fault. After you have cleared the fault, the Auto Gen Start returns to its last known AGS Mode.

Table 5-2 Auto Gen Start fault messages

Fault Number	Message	Self-clearing?	Cause	Action
F200	Exceeded max number of start tries. Check gen, clear fault.	No	The Auto Gen Start has tried and failed to start the generator. To prevent draining the start battery, the Auto Gen Start will suspend further start attempts.	Check the generator's fuel level and start battery condition. Consult generator manual. Clear fault on System Control Panel screen to allow retry.
F201	Unable to stop gen. Stop gen via its control panel.	No	The Auto Gen Start has lost contact with the generator or the generator did not stop after the Auto Gen Start sent it a stop signal.	Change the Auto Gen Start mode to Manual Off. If this fails to work, stop the generator with the external stop switch. Check generator. Return Auto Gen Start to automatic mode to resume automatic starts and stops.
F203	Manual Off: Gen stopped by ext sensor. Reset AGS mode.	No	An external sensor connected to the Auto Gen Start has stopped the generator and put the Auto Gen Start into Manual Off mode.	After the sensor connected to the external shutdown has deactivated, clear the fault and reset the Auto Gen Start to the desired mode.
F500	Serial Number Failure, Service Required.	No	The silicon serial ID number has failed and the Auto Gen Start has gone into Safe mode.	Call your dealer or Xantrex.
F501	Memory Failure. Service Required.	No	The Auto Gen Start has suffered a non-volatile memory failure.	Call your dealer or Xantrex.
F505	Internal Failure. Service Required.	No	A controller fault has occurred and the Auto Gen Start has gone into Safe mode.	Clear the fault. If the fault persists, call your dealer or Xantrex.

A

Specifications

Appendix A contains the electrical, mechanical, and environmental specifications for the Auto Gen Start.

All specifications are subject to change without notice.

Electrical Specifications

Nominal input network voltage	15 VDC
Minimum operating network voltage	14.25 VDC
Maximum operating network voltage	15.75 VDC
Maximum operating current	200 mA @ nominal input network voltage
Relay contact voltage rating	12 VDC, 30 VDC max.
Maximum relay current	5 A DC*
Nominal 12 V/24 V thermostat input voltage	12 VDC/24 VDC = On
Minimum 12 V/24 V thermostat input voltage	9.5 VDC
Maximum 12 V/24 V thermostat input voltage	30 VDC
Typical 12 V/24 V thermostat input current	14.6 mA @ 12 V
Nominal 12 V/24 V generator running B+ voltage	12 VDC/24 VDC = On
Minimum 12 V/24 V generator running B+ voltage	9.5 VDC
Maximum 12 V/24 V generator running B+ voltage	30 VDC
Typical 12 V/24 V generator running B+ current	14.6 mA @ 12 V
Communication physical layer	2, CAN
Communication protocol	Xanbus
Maximum cable length	130 ft. (40 m)

*Limited to Class 2 levels (100 VA) as in Chapter 2, page 2–6.

Mechanical Specifications

Dimensions	$5 \frac{3}{4} \times 3 \frac{3}{4} \times 1 \frac{1}{2}$ " (146 × 95.5 × 37 mm)
Weight	0.5 lb. (225 g)
Mounting	4 #6 screws
Connectors	2 × Xanbus: RJ45—8 pins 20-contact pluggable connector (Tyco Mate 'n' Lok 2 connector)

Environmental Specifications

Operating temperature	-4 to 122 °F (-20 to 50 °C)
Storage temperature	-40 to 185 °F (-40 to 85 °C)
Maximum case temperature	140 °F (60 °C)
Operating humidity	5 to 95%
Storage humidity	5 to 95%
Ignition protection	None

Regulatory Compliance

Safety	CSA certified to CSA107.1-01 and UL 458 4th Ed. including the Marine Supplement
EMC	FCC part 15B Class B Industry Canada ICES-0003 Class B

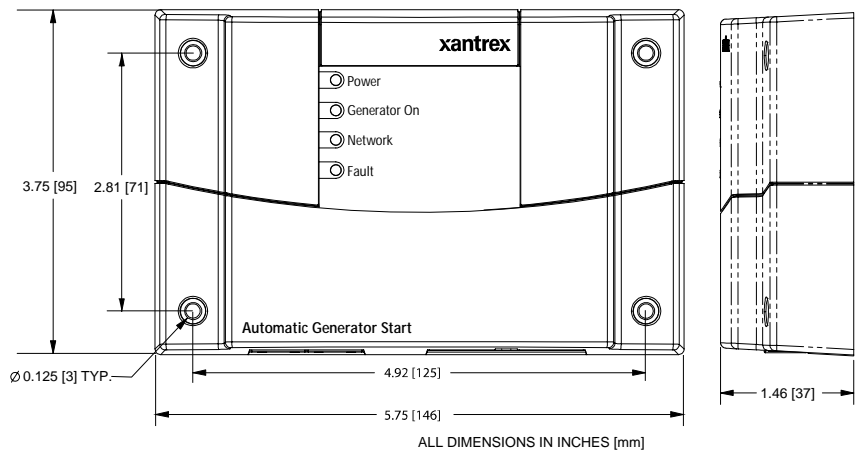

Figure A-1 Auto Gen Start dimensions

B

Generator Auto Start Requirements and Types

Appendix B describes the generator requirements and starting types that can be used with the Auto Gen Start.

Recommended Features

In order for the generator to be automatically started by the Auto Gen Start, it must include electric start and an automatic choke. An automatic primer system may also be required on natural gas and propane powered generators. The generator should also include remote start ability with accessible remote start terminals or a connector. Protective systems for low oil pressure, over temperature, starter lockout and over crank control are valuable features that will prevent generator damage and increase system reliability. “Two-wire” start generators are highly recommended because of the greater simplicity for automatic starting and because they are intended for remote/automatic/unattended operation.

Generator Starting Types

The Auto Gen Start supports three major generator starting types:

- Two wire
- Three-wire “Onan”
- Three-wire automotive

Note: the terms “two-wire” and “three-wire” refer only to the minimum number of wires necessary to start the generator. Actual installations will require additional wires to connect to the generator, including the generator run signal (switched B+) wiring, and wiring to an optional external on/off switch. For installation wiring diagrams, see page 2–10 to page 2–25.

Note: For overcurrent protection guidelines that apply to the wiring types discussed in this appendix, see page 2–6.

Two wire

The two-wire type is suitable for generators that are fully automatic. This merely requires two wires to be connected together for the generator to start and run. Separating the wires stops the generator.

Some generators use a momentary two-wire connection for starting and stopping.

Identification

Generators of this type are usually operated with a simple toggle switch or key that turns to on, then off to shut the generator off.

Connection

For this type of generator, the two wires are connected to the normally open and common contacts of Relay 1 (wires 14 and 16). When the AGS receives a command to start the generator, it closes the contacts inside Relay 1, allowing the generator to start. The contacts remain closed for the duration of the generator run and open when the AGS needs the generator to stop.

Three-Wire Onan

The three-wire “Onan” starting type is suitable for generators that are not as automated as the two-wire type. It requires a minimum of three wires: a common wire, a start wire and a stop wire. You may also need to connect the glow plug wires to Relay 1 (wire 14) or Relay 3 (wire 19). If the generator requires independent control of the glow plugs, power may also need to be run to Relay 3 (wire 20).

Identification

Generators of this type are controlled with a three-position switch that is normally in a center (or neutral) position. To start the generator, the switch is pressed and held to the start position until the generator starts. The switch is then released, and it returns to the center position. To stop the generator, the switch is pressed and held to the stop position until the generator stops. Again, releasing the switch returns it to the center position.

Connection

The common wire from the generator should connect to the common connections of both Relay 1 and Relay 2 (wires 16 and 18 respectively). The start wire from the generator connects to the normally open contact of Relay 2 and the generator stop wire connects to the normally open contact of Relay 1.

Three-Wire Automotive

The third generator starting type that is supported by the AGS is similar to an automotive-style ignition. In this style, the generator uses a run circuit that is normally closed, which then receives a momentary start signal. The run circuit remains active throughout the run and then is opened in order for the generator to stop.

Identification

Generators of this type are controlled by a key or rotary switch that acts exactly as an automotive ignition. The switch is first turned to an “on” (or run) position, then further to a start position. After starting, the switch returns to the “on” (or run) position. Other variations are a toggle switch that gets turned on with a separate switch or pushbutton for start. If glow plugs are used, you would turn the key or rotary switch to the left prior to starting. A separate momentary switch or button may be used for this purpose.

Connection

This generator starting type uses the most wires. The common wire from the generator should connect to the common connections of both Relay 1 and Relay 2 (wires 16 and 18 respectively). You may need an additional two wires if glow plugs are used. The start wire from the generator connects to the normally open contact of Relay 2 and the generator stop wire connects to the normally open contact of Relay 1.

C

Relay Timing

Appendix C contains information about relay configuration and timing for each major type of Auto Gen Start starting mode. This information applies to each of the generator types described from page 2–10 to page 2–20.

RunMode

For generators with RunMode starting types (Types 7 and 8):

- Relay 1 (Run/Stop relay) can be used for two-wire configured generators.
- Relay 1 (Run/Stop) and Relay 2 (Start) can be used with a common ground for three-wire configured generators.
- The Preheat will never overlap the Crank Time.
- The “Delay” refers to the “Preheat to Crank Delay” and may be zero.
- Cranking will cease when the generator run signal goes high for the specified hold time or when the crank time has elapsed.

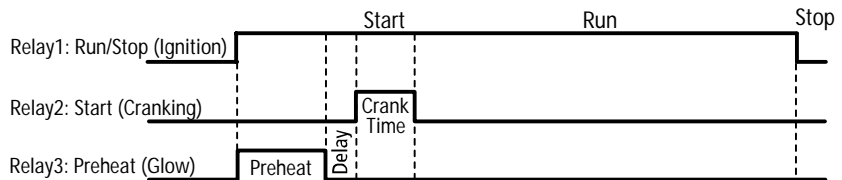

Figure C-1 RunMode timing diagram

MomentaryRun Mode

For generators with MomentaryRun mode starting types (Type 11):

- Relay 1 (Run/Stop relay) can be used for two-wire configured generators.
- Relay 2 has no unique function in this configuration, but it is easiest to leave it doing the cranking so that another configuration is not required for it.
- Preheat will generally not be used in this configuration.
- The Preheat will never overlap the Crank Time.
- The “Delay” refers to the “Preheat to Crank Delay” and may be zero.
- Cranking will cease when the generator run signal goes high for the specified hold time or when the crank time has elapsed.

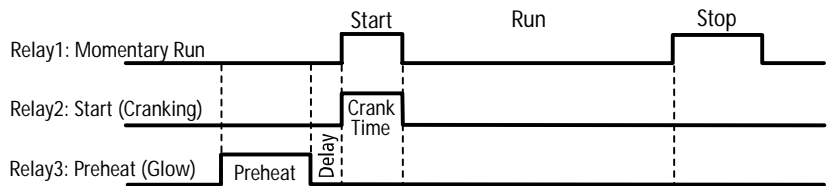

Figure C-2 MomentaryRun mode timing diagram

GlowStop Mode

For generators with GlowStop mode starting types (Types 1, 2, 3, 6, 12):

- Relay 1 (Stop) and Relay 2 (Start) can be used with a common ground for three-wire configured generators.
- The Preheat signal shows up on Relay 1 and also Relay 3 (if enabled) so that Relay 1 can be used for both Preheat and Stop.
- If the ShutDown Bypass is enabled, the Preheat on Relay 1 will remain high for the Crank Time and for the ShutDown Bypass period after cranking.
- The Preheat on Relay 3 will only overlap the Crank Time and perform ShutDown Bypass if Relay 3 is configured for Preheat with ShutDown Bypass.
- The “Delay” refers to the “Preheat to Crank Delay” and may be zero.
- Cranking will cease when the generator run signal goes high for the specified hold time or when the crank time has elapsed.

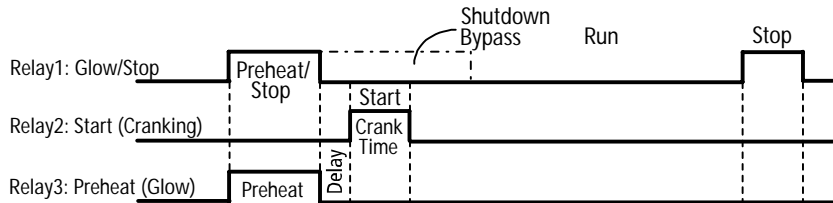

Figure C-3 GlowStop mode timing diagram

StartStop Mode

For generators with StartStop mode starting types (Types 4, 5, 9, 10):

- Relay 1 (Stop) and Relay 2 (Start) can be used with a common ground for three-wire configured generators.
- If Relay 3 is configured for preheat, the signal only shows up on Relay 3.
- The Preheat on Relay 3 will not overlap the Crank Time if ShutDown Bypass is not enabled.
- If the ShutDown Bypass is enabled, the Preheat on Relay 3 will remain high for the Crank Time and for the ShutDown Bypass period after cranking.

- The “Delay” refers to the “Preheat to Crank Delay” and may be zero.
- Cranking will cease when the generator run signal goes high for the specified hold time or when the crank time has elapsed.
- To get the ShutDown Bypass on Relay 3 with no preheat, Relay 3 must be configured for Preheat with ShutDown Bypass and have the Preheat time set to zero.
- StartStop mode is essentially the same as GlowStop mode with no preheat on Relay 1.

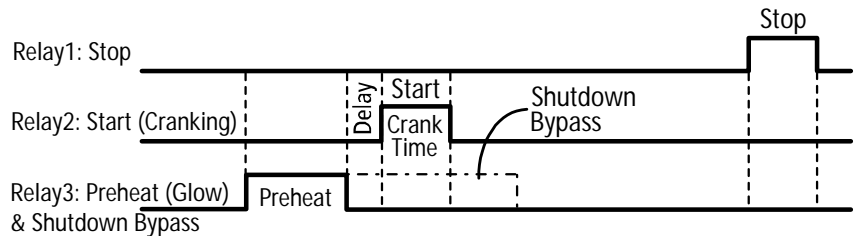

Figure C-4 StartStop mode timing diagram

PulseStop Mode

For generators with PulseStop mode starting types (Type 13):

- Relay 1 (Stop) and Relay 2 (Start) can be used with a common ground for three-wire configured generators.
- If Relay 3 is configured for Preheat, the signal only shows up on Relay 3.
- The Preheat on Relay 3 will not overlap the Crank Time if ShutDown Bypass is not enabled.
- If the ShutDown Bypass is enabled, the Preheat on Relay 3 will remain high for the Crank Time and for the ShutDown Bypass period after cranking.
- The “Delay” refers to the “Preheat to Crank Delay” and may be zero.
- Cranking will cease when the generator run signal goes high for the specified hold time or when the crank time has elapsed.
- To get the ShutDown Bypass on Relay 3 with no preheat, Relay 3 must be configured for Preheat with ShutDown Bypass and have the Preheat time set to zero.

- The Auto Gen Start will make three attempts to stop the generator. If the generator has still not stopped at the end of the third attempt, the appropriate Fault will be generated.
- Each stop attempt will consist of engaging the stop relay for 5 seconds and then waiting 20 seconds before checking the state of the Gen Run Signal to see if the stop attempt was successful.

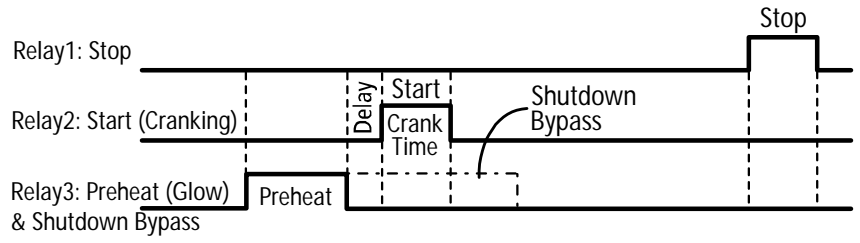

Figure C-5 PulseStop mode timing diagram

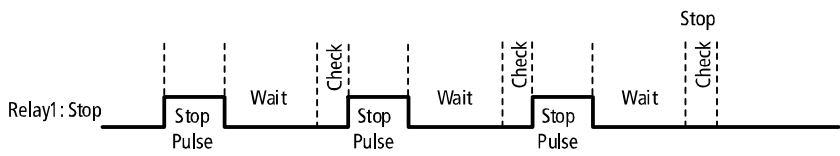

Figure C-6 PulseStop mode Relay 1 behavior

Warranty and Return Information

Warranty

What does this warranty cover? This Limited Warranty is provided by Xantrex Technology, Inc. ("Xantrex") and covers defects in workmanship and materials in your Automatic Generator Start. This warranty period lasts for 12 months from the date of purchase at the point of sale to you, the original end user customer. You require proof of purchase to make warranty claims.

This Limited Warranty is transferable to subsequent owners but only for the unexpired portion of the Warranty Period. Subsequent owners also require proof of purchase.

What will Xantrex do? Xantrex will, at its option, repair or replace the defective product free of charge, provided that you notify Xantrex of the product defect within the Warranty Period, and provided that Xantrex through inspection establishes the existence of such a defect and that it is covered by this Limited Warranty.

Xantrex will, at its option, use new and/or reconditioned parts in performing warranty repair and building replacement products. Xantrex reserves the right to use parts or products of original or improved design in the repair or replacement. If Xantrex repairs or replaces a product, its warranty continues for the remaining portion of the original Warranty Period or 90 days from the date of the return shipment to the customer, whichever is greater. All replaced products and all parts removed from repaired products become the property of Xantrex.

Xantrex covers both parts and labor necessary to repair the product, and return shipment to the customer via a Xantrex-selected non-expedited surface freight within the contiguous United States and Canada. Alaska and Hawaii are excluded. Contact Xantrex Customer Service for details on freight policy for return shipments outside of the contiguous United States and Canada.

How do you get service? If your product requires troubleshooting or warranty service, contact your merchant. If you are unable to contact your merchant, or the merchant is unable to provide service, contact Xantrex directly at:

Telephone: 1 800 670 0707 (toll free North America)

1 360 925 5097 (direct)

Fax: 1 800 994 7828 (toll free North America)

1 360 925 5143 (direct)

Email: customerservice@xantrex.com

Direct returns may be performed according to the Xantrex Return Material Authorization Policy described in your product manual. For some products, Xantrex maintains a network of regional Authorized Service Centers. Call Xantrex or check our website to see if your product can be repaired at one of these facilities.

What proof of purchase is required? In any warranty claim, dated proof of purchase must accompany the product and the product must not have been disassembled or modified without prior written authorization by Xantrex.

Proof of purchase may be in any one of the following forms:

- The dated purchase receipt from the original purchase of the product at point of sale to the end user, or
- The dated dealer invoice or purchase receipt showing original equipment manufacturer (OEM) status, or
- The dated invoice or purchase receipt showing the product exchanged under warranty

What does this warranty not cover? This Limited Warranty does not cover normal wear and tear of the product or costs related to the removal, installation, or troubleshooting of the customer's electrical systems. This warranty does not apply to and Xantrex will not be responsible for any defect in or damage to:

- a) the product if it has been misused, neglected, improperly installed, physically damaged or altered, either internally or externally, or damaged from improper use or use in an unsuitable environment;
- b) the product if it has been subjected to fire, water, generalized corrosion, biological infestations, or input voltage that creates operating conditions beyond the maximum or minimum limits listed in the Xantrex product specifications including high input voltage from generators and lightning strikes;
- c) the product if repairs have been done to it other than by Xantrex or its authorized service centers (hereafter "ASCs");
- d) the product if it is used as a component part of a product expressly warranted by another manufacturer;
- e) the product if its original identification (trade-mark, serial number) markings have been defaced, altered, or removed.

Disclaimer

Product

THIS LIMITED WARRANTY IS THE SOLE AND EXCLUSIVE WARRANTY PROVIDED BY XANTREX IN CONNECTION WITH YOUR XANTREX PRODUCT AND IS, WHERE PERMITTED BY LAW, IN LIEU OF ALL OTHER WARRANTIES, CONDITIONS, GUARANTEES, REPRESENTATIONS, OBLIGATIONS AND LIABILITIES, EXPRESS OR IMPLIED, STATUTORY OR OTHERWISE IN CONNECTION WITH THE PRODUCT, HOWEVER ARISING (WHETHER BY CONTRACT, TORT, NEGLIGENCE, PRINCIPLES OF MANUFACTURER'S LIABILITY, OPERATION OF LAW, CONDUCT, STATEMENT OR OTHERWISE), INCLUDING WITHOUT RESTRICTION ANY IMPLIED WARRANTY OR CONDITION OF QUALITY, MERCHANTABILITY OR FITNESS FOR A PARTICULAR PURPOSE. ANY IMPLIED WARRANTY OF MERCHANTABILITY OR FITNESS FOR A PARTICULAR PURPOSE TO THE EXTENT REQUIRED UNDER APPLICABLE LAW TO APPLY TO THE PRODUCT SHALL BE LIMITED IN DURATION TO THE PERIOD STIPULATED UNDER THIS LIMITED WARRANTY.

IN NO EVENT WILL XANTREX BE LIABLE FOR ANY SPECIAL, DIRECT, INDIRECT, INCIDENTAL OR CONSEQUENTIAL DAMAGES, LOSSES, COSTS OR EXPENSES HOWEVER ARISING WHETHER IN CONTRACT OR TORT INCLUDING WITHOUT RESTRICTION ANY ECONOMIC LOSSES OF ANY KIND, ANY LOSS OR DAMAGE TO PROPERTY, ANY PERSONAL INJURY, ANY DAMAGE OR INJURY ARISING FROM OR AS A RESULT OF MISUSE OR ABUSE, OR THE INCORRECT INSTALLATION, INTEGRATION OR OPERATION OF THE PRODUCT.

Exclusions

If this product is a consumer product, federal law does not allow an exclusion of implied warranties. To the extent you are entitled to implied warranties under federal law, to the extent permitted by applicable law they are limited to the duration of this Limited Warranty. Some states and provinces do not allow limitations or exclusions on implied warranties or on the duration of an implied warranty or on the limitation or exclusion of incidental or consequential damages, so the above limitation(s) or exclusion(s) may not apply to you. This Limited Warranty gives you specific legal rights. You may have other rights which may vary from state to state or province to province.

Warning: Limitations On Use

Please refer to your product manual for limitations on uses of the product.

SPECIFICALLY, PLEASE NOTE THAT THE AUTOMATIC GENERATOR START SHOULD NOT BE USED IN CONNECTION WITH LIFE SUPPORT SYSTEMS OR OTHER MEDICAL EQUIPMENT OR DEVICES. WITHOUT LIMITING THE GENERALITY OF THE FOREGOING, XANTREX MAKES NO REPRESENTATIONS OR WARRANTIES REGARDING THE USE OF THE XANTREX AUTOMATIC GENERATOR START IN CONNECTION WITH LIFE SUPPORT SYSTEMS OR OTHER MEDICAL EQUIPMENT OR DEVICES.

Return Material Authorization Policy

Before returning a product directly to Xantrex you must obtain a Return Material Authorization (RMA) number and the correct factory "Ship To" address. Products must also be shipped prepaid. Product shipments will be refused and returned at your expense if they are unauthorized, returned without an RMA number clearly marked on the outside of the shipping box, if they are shipped collect, or if they are shipped to the wrong location.

Warranty and Return

When you contact Xantrex to obtain service, please have your instruction manual ready for reference and be prepared to supply:

- The serial number of your product
- Information about the installation and use of the unit
- Information about the failure and/or reason for the return
- A copy of your dated proof of purchase

Record these details in “Information About Your System” on page WA-5.

Return Procedure

1. Package the unit safely, preferably using the original box and packing materials. Please ensure that your product is shipped fully insured in the original packaging or equivalent. This warranty will not apply where the product is damaged due to improper packaging.
2. Include the following:
 - The RMA number supplied by Xantrex Technology, Inc. clearly marked on the outside of the box.
 - A return address where the unit can be shipped. Post office boxes are not acceptable.
 - A contact telephone number where you can be reached during work hours.
 - A brief description of the problem.
3. Ship the unit prepaid to the address provided by your Xantrex customer service representative.

If you are returning a product from outside of the USA or Canada In addition to the above, you **MUST** include return freight funds and are fully responsible for all documents, duties, tariffs, and deposits.

If you are returning a product to a Xantrex Authorized Service Center (ASC) A Xantrex return material authorization (RMA) number is not required. However, you must contact the ASC prior to returning the product or presenting the unit to verify any return procedures that may apply to that particular facility.

Out of Warranty Service

If the warranty period for your Automatic Generator Start has expired, if the unit was damaged by misuse or incorrect installation, if other conditions of the warranty have not been met, or if no dated proof of purchase is available, your product may be serviced or replaced for a flat fee.

To return your Automatic Generator Start for out of warranty service, contact Xantrex Customer Service for a Return Material Authorization (RMA) number and follow the other steps outlined in “Return Procedure” on page WA-4.

Payment options such as credit card or money order will be explained by the Customer Service Representative. In cases where the minimum flat fee does not apply, as with incomplete units or units with excessive damage, an additional fee will be charged. If applicable, you will be contacted by Customer Service once your unit has been received.

Information About Your System

As soon as you open your Automatic Generator Start package, record the following information and be sure to keep your proof of purchase.

- Serial Number _____
- Purchased From _____
- Purchase Date _____

If you need to contact Customer Service, please record the following details before calling. This information will help our representatives give you better service.

- Type of installation (e.g. RV, truck) _____
- Length of time Auto Gen Start has been installed _____
- Battery/battery bank size _____
- Generator brand/type _____
- DC wiring size and length _____
- Alarm sounding? _____
- Description of indicators on front panel _____
- Appliances operating when problem occurred _____
- Warning or Fault message _____
- Description of problem _____

Index

A

- Advanced menu 3–18
- AGS Mode 3–9
- AGS Triggers menu 3–19
- asterisk beside selected value 3–5
- automatic mode 3–9

B

- B+ wires 2–8
- Basic menu 3–7, 3–18
- bottom panel features 1–6

C

- Clear Faults 3–17
- clearing faults 5–2
- Configure Gen 3–18
- Configure Triggers 3–18
- Crank Retry Time 3–33
- Crank Time 3–32
- Customer Service
 - preparing to call WA–5

D

- DC Monitor 1–4, 3–9, 3–13, 3–14, 3–19, 3–20, 3–21
- default settings, restoring 3–35
- Device Info 3–18
- Device Info menu 3–35
- displaying 3–18
- Down arrow button 3–3

E

- electrical specifications A–2
- Enable Load 3–23
- Enable Temp1 3–15, 3–23
- Enable Temp2 3–16, 3–23
- Enter button 3–3
- environmental specifications A–3
- Event Log 3–35

- Exercise Duration 3–30
- Exercise Period 3–29
- Exercise Time 3–31
- Exit button 3–3
- external LED wire 2–8, 2–24
- external on/off LED 2–24
- external shutdown switch
 - connecting to wiring harness 2–23
 - input and return 2–8, 2–23

F

- Fault light 1–5
- Fault Log 3–35
- fault messages
 - acknowledging 5–2
 - clearing 5–2
 - reference table 5–5
- firmware revision number iii, 4–8
- front panel features 1–5

G

- Gen Status 3–8
- Gen Type 3–16
- generator
 - auto start requirements B–1
 - connector 1–6
 - type 3–16
- Generator On light 1–5
- generator run signal 2–8
- generator starting modes
 - glowstop C–4
 - momentary run C–3
 - pulsestop C–5
 - run C–2
 - startstop C–4

H

- Hibernate mode 4–8

I

Information about Your System form WA-5

M

manual off mode 3-10
manual on mode 3-10
Max Run Time 3-29
mechanical specifications A-2
modes 4-6
momentary run mode C-3

N

network connector 1-6
Network light 1-5
network power consumption 1-4
network-managed power system 1-7

O

Operating mode 4-7

P

Power light 1-5
Power Save mode 4-7
Preheat Time 3-33
proof of purchase WA-5
pulsestop mode C-5
purchase date WA-5

Q

Quiet Time
 Begin 3-11
 disabling 3-12
 Enable 3-11
 End 3-13

R

regulatory listings A-3
Relay3 3-31
Restore Defaults 3-35
Run Hold Time 3-32

run mode C-2

S

Safe mode 4-7
Select Device menu 3-3
serial number
 recording WA-5
settings
 adjusting 3-4
 quiet time 4-3
specifications A-2
Start DC V 3-14, 3-20
Start Load 3-24
Start SOC 3-13
Start Tries 3-34
Start Trigger 3-8
Starter Cool Down 3-28
startstop mode C-4
StartV
 15min 3-20
 24Hr 3-22
 2Hr 3-21
Stop Absorb 3-25
Stop BattV 3-22
Stop Float 3-26
Stop Load 3-25
Stop SOC 3-19
storage 4-8
switched B+ wires 2-8
system components 1-7
System Control Panel
 buttons described 3-3
 changing Auto Gen Start settings 3-3
 connecting 2-26
system modes 4-6

T

thermostat
 connecting 2-23
 connector 1-6
 inputs and returns 2-8, 2-23
thermostats, enabling 3-15, 3-16, 3-23
Triggers menu 3-19

U

Up arrow button 3–3
user settings reference table 3–36

V

verifying network power 2–26

W

Warning Log 3–35
warning messages
 acknowledging 5–2
 reference table 5–3
warranty
 out of warranty service WA–4
 terms and conditions WA–1

X

Xanbus 1–2
Xantrex
 web site ii, v, 1–2

Xantrex Technology Inc.

1 800 670 0707 Tel toll free NA
1 360 925 5097 Tel direct

1 800 994 7828 Fax toll free NA
1 360 925 5143 Fax direct

customerservice@xantrex.com

www.xantrex.com