

## MOUNTING

- Mount pump within 6 feet of tank for best performance.
- Mount pump in a space of two cubic foot for adequate ventilation.
- The pump may be mounted in any position. If mounting the pump vertically, the pump head should face down.
- Choose a **solid** surface. **Do not insulate the baseplate heat sink. Heat sink must be free and have air flowing across.**
- Do not over-tighten mounting feet.

## ELECTRICAL

**CAUTION** RED PUMP WIRE MUST BE CONNECTED TO POSITIVE POWER OR CONTROLLER WILL BE DAMAGED!!!

- The pump should be on an individual circuit, protected by the specified size fuse or circuit breaker on the label.
- A 15 amp or higher switch is recommended, and must be on the positive (+ red) lead.
- **TEST INCOMING POWER WITH MULTIMETER TO TEST POLARITY ( RED = + and BLACK = -- ).**
- Pump draws 15 milliamps when pump is powered on, even when the pump is not running.

**SHUT OFF POWER TO PUMP WHEN LEAVING COACH.**

Wire Size for a 10% voltage drop on a 12VDC, 15 Amp Circuit	
Length is distance from power source to pump and back to ground	
0-20 Ft [0-6M]	= 14GA [2.5mm <sup>2</sup> ]
20-50 Ft [6-15M]	= 12GA [4mm <sup>2</sup> ]
50-70 Ft [15-21M]	= 10GA [6mm <sup>2</sup> ]
70-100 Ft [21-30M]	= 8GA [10mm <sup>2</sup> ]

**Electrical Connection with 10 Amp or 15 Amp Controller**  
Disconnect wires from current pump and connect to Smart Sensor Pump. Make sure wires are at least 14GA [2.5mm<sup>2</sup>].

**Electrical Hook-Up with 7Amp Intellitec Controller**  
Replace 7 Amp controller with 10 Amp or 15 Amp Controller, or install relay as shown below. The purpose of the relay is to allow the 7 amp controller to close the circuit on the relay allowing a higher amp circuit to run the pump. Common name for the relay is a Bosch 30-Amp automotive-type relay. Turn off all power before electrical work.

### Relay Installation

1. Splice 2 red wires into the incoming power line to +12V.
2. Connect one red wire to the red fused pump wire.
3. Connect one red wire to relay terminal 85.
4. Remove wire from the controller LOAD terminal to the black (-) pump wire and connect it to relay terminal 87.
5. Make a jumper wire from LOAD to relay terminal 86.
6. Splice ground wire from relay terminal 30 to controller GND terminal and circuit ground.
7. Leave wire to SW terminal connected to switches.

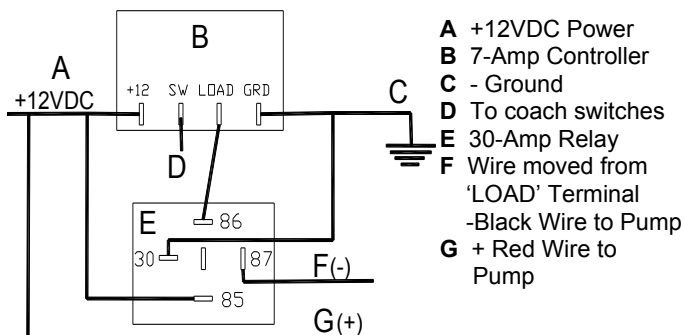

## PLUMBING

- Installation of a strainer (SHURflo model 254 or larger) is required to prevent debris from entering the pump.
- For noise and vibration reduction we recommend at least 18 in. [.5 M] of 1/2" [13mm] I.D. flexible high-pressure tubing to both ports. The pump ports and strainer **should not** be connected to plastic or rigid pipe.
- SHURflo quick-connect fittings provide easy installation and removal if required. The fittings are designed with dual o-rings, creating a seal when snapped into place. Lubricate o-rings with silicone-based grease.
- **NOTE: Remove clips completely from pump during maintenance and storage to avoid distortion.**

### To Insert Fittings:

**Clips have the word 'FITTING' on them**

1. Hold fitting with 1/2" wrench and tighten plumbing to fitting.
2. Make sure o-rings are lubricated
3. Insert fitting into quick-connect port.
4. Snap lock clip over fitting and lock tab with 'fitting' facing out toward fitting.

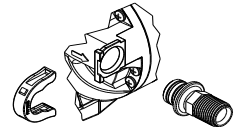

### To Remove Fittings:

1. Pry up edge of lock clip over lock tab one at a time.
2. Remove clip and slide fitting out of port.

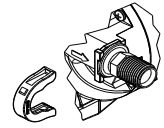

**Fully install clips or remove completely during maintenance and storage.**



## TROUBLESHOOTING & MAINTENANCE

**Regularly check all fittings/screws/connections**  
**PUMP WILL NOT START/ BLOWS CIRCUIT**

- ✓ Electrical connections, fuse, breaker, main switch, and ground connection.
- ✓ Is the motor hot? Self-resetting thermal breaker may have triggered.
- WILL NOT PRIME/SPUTTERS** (No discharge/Motor runs)
- ✓ Is the strainer clogged with debris?
- ✓ Is there water in the tank, or air in the hot water heater?
- ✓ Is the inlet plumbing sucking in air at connections (vacuum leak)?
- ✓ Is inlet/outlet plumbing severely restricted or kinked?

**PUMP WILL NOT SHUT OFF/RUNS WHEN FAUCET IS CLOSED**

- ✓ Output side plumbing for leaks, and inspect for leaky valves or toilet.
- ✓ For air trapped in outlet side (water heater) or pump head.

### NOISY OR ROUGH OPERATION

- ✓ For plumbing which may have vibrated loose.
- ✓ Is pump plumbed with rigid pipe?
- ✓ Does the mounting surface amplify noise?
- ✓ For mounting feet that are loose or compressed too tight.
- ✓ For air in system.

**Sanitizing:** SHURflo recommends sanitizing your system every year or as needed for maintenance. Follow your manufacturer's recommended procedures.

**Winterizing:** Follow your manufacturer's recommendations. Do not allow

## LIMITED WARRANTY

SHURflo warrants The Extreme series RV pump to be free from material and workmanship defects under normal use and service for a period of (3) three years from the date of purchase. In the absence of proof of purchase the warranty is (3) three years from the date of manufacture indicated on the motor nameplate. SHURflo is not responsible nor will it reimburse for labor necessary to remove and reinstall a pump, if found defective. Contact SHURflo for complete Limited Warranty details.



★ISO Certified Facility



SHURflo reserves the right to update specifications, prices, or make substitutions

SHURflo, LLC★  
5900A Katella Ave.  
Cypress, CA 90630  
(800) 854-3218  
(562) 795-5200  
FAX (562) 795-7564

SHURflo, LLC East  
52748 Park Six Court  
Elkhart, IN 46514-5427  
(800) 762-8094  
(574) 262-0478  
FAX (574) 264-2169  
www.shurflo.com

© 2004-2005 All Rights Reserved

SHURflo Ltd.  
Unit 5 Sterling Park  
Gatwick Road, Crawley  
West Sussex, RH10 2QT  
United Kingdom  
+44 1293 424000  
FAX +44 1293 421880



## IMPORTANT

### READ INSTRUCTIONS ENTIRELY BEFORE INSTALLING THE SMART SENSOR 5.7

These are generalized instructions. For detailed installation, maintenance and troubleshooting and limited warranty information, contact SHURflo or visit <http://www.shurflo.com>.

**For smooth, maximized flow and less noise and vibration, we offer these suggestions:**

- Use a minimum  $\frac{1}{2}$ " [13mm] diameter tubing. Eliminate any unnecessary restrictive elbow fittings and valves
- Mount pump on solid surface. Do not over-tighten rubber feet.
- Use flexible high-pressure hose on pump inlet and outlet.

Use Optional SHURflo Pump Silencing Kit, Model 94-591-01.

- Use an Extreme Series High-Flow water strainer [Model # 254-266].
- Wire Size: 14GA [2.5mm<sup>2</sup>] **minimum**, 12GA [4mm<sup>2</sup>] recommended. See chart on page 2.
- Bleed all air from system.
- Reducing restrictions on the inlet side will allow the pump to run freely, reducing cavitation (starving & noise).
- Reducing restrictions to pump outlet side will minimize backpressure, allowing the pump to run freely.
- Minimum suggested requirement is **2 ft<sup>3</sup> [.06M<sup>3</sup>] of space around pump**. Less area around pump can cause the thermal overload to turn off pump at about 20 minutes of operation. More airflow is better for cooling pump.
- Pump is designed for intermittent duty only.
- **Minimum power requirement is 15 AMPS.**
- **If coach has an Intellitec latching pump controller**, see wire diagram on page 2.
- **Pump shut-off pressure is 65 PSI [4.5 Bar]**. System must be designed to handle 65 PSI [4.5 Bar].
- Pump draws 15 milliamps continuously when pump switch is on, even when pump is not running.

**ALWAYS SHUT OFF POWER TO PUMP WHEN LEAVING COACH.**

### OPERATION

**THIS PUMP IS NOT DESIGNED FOR CONTINUOUS DUTY OR FOR USE AS A REVERSE OSMOSIS (RO) PUMP. PLEASE CONTACT SHURFLO, OR VISIT WWW.SHURFLO.COM FOR YOUR INDIVIDUAL NEEDS.**

In a high flow application, the pump will function normally. In a low flow application, the pump will sense a build-up in pressure, send a signal to the motor and slow down, with virtually no cycling and very low noise. When the fixture is closed, pressure will build up and the pump will shut off. Pump draws 15 milliamps continually when pump switch is on.

**Always turn pump off when not in use for long periods of time, or when leaving your coach.**

The pump fully breaks in after a few hours on time. The diaphragm and valves better seat themselves and the motor brushes will make full contact. What this means for you is a little higher flow and lower amp consumption. Make sure you purge **all** of the air in your system.

- A Battery
- B Fuse. See label for proper size.
- C 15 Amp [minimum] switch
- D Red (+) wire. See chart for size.
- E Black (- Ground) wire. See chart for size.
- F Pump
- G Model 254 series strainer
- H Pump inlet flex line
- I Pump outlet flex line

- Fittings
- 94-615-01 - 1/2"
  - 94-615-00 - 1/2"
  - 94-615-03 - Coupler
  - 94-615-04 - 3/4"
  - 94-615-05 - 3/4"
  - 94-615-06 - 1/2" NPS-M

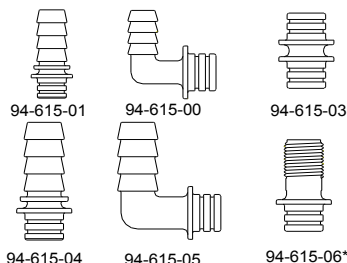

\*2 supplied with pump

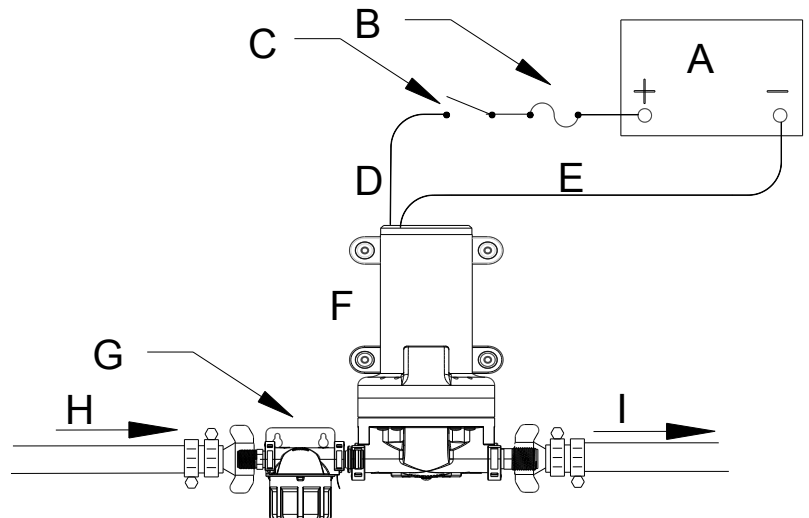

**Pump Dimensions (with fittings and strainer):**  
9-1/2" [24cm] x 12-1/2" [32cm] x 6" [16cm]